

***SERVICE MANUAL***

**HP-IB DC Power Supplies  
HP Series 668xA**

**HP Part No. 5960-5590**

**For instruments with Serial Numbers:**

**HP Model 6680A: US36480101 and Above \***  
**HP Model 6681A: US36400101 and Above \***  
**HP Model 6682A: US36440101 and Above \***  
**HP Model 6683A: US36420101 and Above \***  
**HP Model 6684A: US36410101 and Above \***

\* This manual also applies to instruments with the older serial number format described on page 7.  
For instruments with higher serial numbers, a change page may be included.  
For instruments with lower serial numbers, see Appendix A.

## **CERTIFICATION**

*Hewlett-Packard Company certifies that this product met its published specifications at time of shipment from the factory. Hewlett-Packard further certifies that its calibration measurements are traceable to the United States National Bureau of Standards, to the extent allowed by the Bureau's calibration facility, and to the calibration facilities of other International Standards Organization members.*

## **WARRANTY**

This Hewlett-Packard hardware product is warranted against defects in material and workmanship for a period of three years from date of delivery. HP software and firmware products, which are designated by HP for use with a hardware product and when properly installed on that hardware product, are warranted not to fail to execute their programming instructions due to defects in material and workmanship for a period of 90 days from date of delivery. During the warranty period Hewlett-Packard Company will, at its option, either repair or replace products which prove to be defective. HP does not warrant that the operation of the software, firmware, or hardware shall be uninterrupted or error free.

For warranty service, with the exception of warranty options, this product must be returned to a service facility designated by HP. Customer shall prepay shipping charges by (and shall pay all duty and taxes) for products returned to HP for warranty service. Except for products returned to Customer from another country, HP shall pay for return of products to Customer.

Warranty services outside the country of initial purchase are included in HP's product price, only if Customer pays HP international prices (defined as destination local currency price, or U.S. or Geneva Export price).

If HP is unable, within a reasonable time to repair or replace any product to condition as warranted, the Customer shall be entitled to a refund of the purchase price upon return of the product to HP.

## **LIMITATION OF WARRANTY**

The foregoing warranty shall not apply to defects resulting from improper or inadequate maintenance by the Customer, Customer-supplied software or interfacing, unauthorized modification or misuse, operation outside of the environmental specifications for the product, or improper site preparation and maintenance. **NO OTHER WARRANTY IS EXPRESSED OR IMPLIED. HP SPECIFICALLY DISCLAIMS THE IMPLIED WARRANTIES OF MERCHANTABILITY AND FITNESS FOR A PARTICULAR PURPOSE.**

## **EXCLUSIVE REMEDIES**

**THE REMEDIES PROVIDED HEREIN ARE THE CUSTOMER'S SOLE AND EXCLUSIVE REMEDIES. HP SHALL NOT BE LIABLE FOR ANY DIRECT, INDIRECT, SPECIAL, INCIDENTAL, OR CONSEQUENTIAL DAMAGES, WHETHER BASED ON CONTRACT, TORT, OR ANY OTHER LEGAL THEORY.**

## **ASSISTANCE**

*The above statements apply only to the standard product warranty. Warranty options, extended support contracts, product maintenance agreements and customer assistance agreements are also available. Contact your nearest Hewlett-Packard Sales and Service office for further information on HP's full line of Support Programs.*

# SAFETY CONSIDERATIONS

**GENERAL.** This is a Safety Class 1 instrument (provided with terminal for connection to protective earth ground).

**OPERATION.** BEFORE APPLYING POWER verify that the product is set to match the available line voltage, the correct line fuse is installed, and all safety precautions (see following warnings) are taken. In addition, note the instrument's external markings described under "Safety Symbols".

## WARNING.

- Servicing instructions are for use by service-trained personnel. To avoid dangerous electrical shock, do not perform any servicing unless you are qualified to do so.
- BEFORE SWITCHING ON THE INSTRUMENT, the protective earth terminal of the instrument must be connected to the protective conductor of the (mains) power cord. The mains plug shall be inserted only in an outlet socket that is provided with a protective earth contact. This protective action must not be negated by the use of an extension cord (power cable) that is without a protective conductor (grounding). Grounding one conductor of a two-conductor outlet is not sufficient protection.
- If this instrument is to be energized via an auto-transformer (for voltage change), make sure the common terminal is connected to the earth terminal of the power source.
- Any interruption of the protective (grounding) conductor (inside or outside the instrument), or disconnecting of the protective earth terminal will cause a potential shock hazard that could result in personal injury.
- Whenever it is likely that the protective earth connection has been impaired, this instrument must be made inoperative and be secured against any unintended operation.
- Only fuses with the required rated current, voltage, and specified type (normal blow, time delay, etc.) should be used. Do not use repaired fuses or short-circuited fuseholders. To do so could cause a shock or fire hazard.
- Do not operate this instrument in the presence of flammable gases or fumes.
- Do not install substitute parts or perform any unauthorized modification to this instrument.
- Some procedures described in this manual are performed with power supplied to the instrument while its protective covers are removed. If contacted, the energy available at many points may result in personal injury.
- Any adjustment, maintenance, and repair of this instrument while it is opened and under voltage should be avoided as much as possible. When this is unavoidable, such adjustment, maintenance, and repair should be carried out only by a skilled person who is aware of the hazard involved.
- Capacitors inside this instrument may hold a hazardous electrical charge even if the instrument has been disconnected from its power source.

## SAFETY SYMBOLS.



Instruction manual symbol. The instrument will be marked with this symbol when it is necessary for you to refer to the instruction manual in order to protect against damage to the instrument.



This sign indicates hazardous voltages.

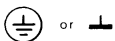

This sign indicates an earth terminal (sometimes used in the manual to indicate circuit common connected to a ground chassis).



The WARNING sign denotes a hazard. It calls attention to a procedure, practice, or the like, which, if not correctly performed or adhered to, could result in personal injury. Do not proceed beyond a WARNING sign until the indicated conditions are fully understood and met.



The CAUTION sign denotes a hazard. It calls attention to an operating procedure, or the like, which, if not correctly performed or adhered to, could result in damage to or destruction of part or all of the product. Do not proceed beyond a CAUTION sign until the indicated conditions are fully understood and met.

# Table of Contents

<b>Introduction .....</b>	<b>7</b>
Scope .....	7
Organization.....	7
Instrument Identification.....	7
Related Documents .....	8
Change Sheet.....	8
Operating Manual.....	8
Revisions.....	8
Manual Revisions.....	8
Firmware Revisions.....	8
Safety Considerations .....	9
Conventions .....	9
Electrostatic Discharge .....	9
<b>Verification.....</b>	<b>11</b>
Introduction.....	11
Tests.....	11
Test Equipment Required.....	11
List of Equipment.....	11
Current-Monitoring Resistor .....	11
Electronic Load.....	12
Programming The Tests .....	13
General Considerations .....	13
Programming Parameters .....	13
General Measurement Techniques .....	13
Performance Test Record Sheets .....	13
Operation Verification Tests.....	14
Performance Tests.....	14
Constant Voltage (CV) Tests .....	14
Test Setup.....	14
Test Procedures .....	14
Constant Current (CC) Tests .....	19
Test Setup.....	19
Test Procedures .....	19
Averaging the CC Measurements.....	24
<b>Troubleshooting.....</b>	<b>33</b>
Introduction.....	33
Localizing the Problem .....	33
Chapter Organization .....	33
Test Equipment Required.....	34
Troubleshooting Procedures .....	34
Power-On Selftest .....	34
Description .....	34
Disabling The Power-On Selftest.....	34
Using the *TST? Query (HP-IB Systems Supplies Only) .....	34
Troubleshooting Charts.....	36
Troubleshooting Test Points .....	36
Bias and Reference Supplies.....	36
CV/CC Status Annunciators Troubleshooting.....	55
A3 FET Board Troubleshooting .....	55
Signature Analysis .....	58

Introduction.....	58
Firmware Revisions.....	58
Test Headers .....	59
Post-Repair Calibration.....	65
When Required .....	65
Inhibit Calibration Jumper .....	65
Calibration Password .....	65
Restoring Factory Calibration Constants.....	65
EEPROM Initialization.....	66
Transferring Calibration Constants To Factory Preset Locations .....	66
Disassembly Procedures .....	71
Tools Required.....	71
Top Cover.....	71
Removing Protective RFI Shield (Galvanized Sheet Metal).....	72
HP-IB Board .....	72
A4 AC Input Assembly .....	72
A5 DC RAIL Assembly .....	73
A6 BIAS Assembly.....	73
A3 FET Board.....	73
A10 Control Assembly.....	73
Front Panel Assembly .....	73
S1 Line Switch.....	74
A1 Front Panel Board .....	74
A1DSP1 LCD Display.....	74
A1G1 and A1G2 Rotary Controls .....	75
A1KPD Keypad .....	75
Output Bus Boards A7, A81 and A9 & Chassis Components.....	75
<b>Principles Of Operation .....</b>	<b>87</b>
Introduction.....	87
A2 HP-IB Board .....	87
A1 Front Panel Assembly .....	88
A10 Control Board.....	88
Secondary Interface (P/O A10 Board).....	88
A4 AC Input Board.....	90
A5 DC Rail Board.....	91
A3 FET Board.....	91
Output Circuits.....	92
<b>Replaceable Parts .....</b>	<b>95</b>
INTRODUCTION .....	95
Chapter Organization .....	95
Reading the Tables.....	95
How To Order Parts.....	96
<b>Diagrams .....</b>	<b>139</b>
Introduction.....	139
Chapter Organization .....	139
General Schematic Notes.....	145
<b>Backdating.....</b>	<b>171</b>
<b>Index .....</b>	<b>173</b>



# Introduction

---

## Scope

## Organization

This manual contains information for troubleshooting and repairing to the component level HP Series 668xA, 5-kilowatt power supplies. The remaining chapters of this manual are organized as follows:

<b>Chapter</b>	<b>Description</b>
Chapter 2	Verification procedures to determine the performance level of the supply either before or after repair.
Chapter 3	Troubleshooting procedures for isolating a problem, procedures for replacing the defective component and, if required, post-repair calibration and EEPROM initialization procedures.
Chapter 4	Principles of power supply operation on a block-diagram level.
Chapter 5	Replaceable parts, including parts ordering information.
Chapter 6	Diagrams, including schematics, component location drawings, and troubleshooting test points.
Appendix A	Backdating information for power supplies with serial numbers below those listed in the title page of this manual.

---

## Instrument Identification

Hewlett-Packard instruments are identified by a 10-digit serial number. The format is described as follows: first two letters indicate the country of manufacture. The next four digits are a code that identify either the date of manufacture or of a significant design change. The last four digits are a sequential number assigned to each instrument.

<b>Item</b>	<b>Description</b>
<b>US</b>	The first two letters indicates the country of manufacture, where US = USA.
<b>3648</b>	This is a code that identifies either the date of manufacture or the date of a significant design change.
<b>0101</b>	The last four digits are a unique number assigned to each power supply.

If the serial number prefix on your unit differs from that shown on the title page of this manual, a yellow Manual Change sheet may be supplied with the manual. It defines the differences between your unit and the unit described in this manual. The yellow change sheet may also contain information for correcting errors in the manual.

Older serial number formats used with these instruments had a two-part serial number, i.e. 2701A-00101. This manual also applies to instruments with these older serial number formats. Refer to Appendix A for backdating information.

## Related Documents

### Change Sheet

There may or may not be a *Manual Change* sheet included with this manual (see Manual Revisions). If one is included, be sure to examine it for changes to this manual.

### Operating Manual

Each power supply is shipped with an operating manual (see Replaceable Parts, Chapter 5 for part numbers) that covers the following topics:

- Options, accessories, specifications, supplementary characteristics, output characteristic curve, typical output impedance curves.
- Connecting the power cord, load, and remote sensing.
- Connecting power supplies in series or autoparallel.
- Connecting the remote controller and setting the HP-IB address.
- Configuring the digital port for remote inhibit, relay link, or digital I/O operation.
- Connecting the analog port for external voltage programming control.
- Turn-on tests, including selftest errors and runtime errors.
- Front panel operation.
- SCPI programming, an introduction to syntax, language dictionary, and status register operation.
- Compatibility-language programming for operation with HP Series 603xA power supplies.
- Replacement of line fuse and conversion of line voltage.
- Calibration procedure (front panel and remote).

---

## Revisions

### Manual Revisions

This manual was written for power supplies that have the same serial prefixes (first part) as those listed on the title page and whose serial numbers (second part) are equal to or higher than those listed in the title page.

- 
- |             |  |
|-------------|--|
| <b>Note</b> | <ol style="list-style-type: none"><li>1) If the serial prefix of your supply is higher than that shown in the title page then the supply was made after the publication of this manual and may have hardware and/or firmware differences not covered in the manual.</li><li>2) If they are significant to the operation and/or servicing of the power supply, those differences are documented in one or more Manual Changes sheets included with this manual.</li><li>3) If the serial prefix on the power supply is lower than that shown on the title page, then the supply was made before the publication of this manual and can be different from that described here. Such differences are covered in "Appendix A - Manual Backdating Changes".</li></ol> |
|-------------|--|
- 

### Firmware Revisions

The power supply's firmware resides in the A10 control board microprocessor chip and in ROM chips on the A2 HP-IB and A1 Front Panel boards. You can obtain the firmware revision number by either reading the integrated circuit label, or query the power supply using the HP-IB \*IDN query command (see Chapter 3 - Troubleshooting). Also, see Chapter 3, Firmware Revisions for the actual HPBASIC program that does this.



---

## Safety Considerations

This power supply is a Safety Class I instrument, which means it has a protective earth terminal. This terminal must be connected to earth ground through a power source equipped with a 4-wire, ground receptacle. Refer to the "Safety Summary" page at the beginning of this manual for general safety information. Before operation or repair, check the power supply and review this manual for safety warnings and instructions. Safety warnings for specific procedures are located at appropriate places in the manual.

---

**WARNING**

Hazardous voltage exist within the power supply chassis, at the output terminals, and at the analog programming terminals.

---

---

## Conventions

- In diagrams, the name of a complementary signal is sometimes shown with a bar above the signal mnemonic. In other diagrams and in the text, complementary signals are shown with an asterisk (\*) after the mnemonic (such as PCLR\*). A mnemonic with a bar over it or an asterisk after it represents the same signal.
- In this manual, all HP 668xA series supplies are referred to as *system* supplies.

---

## Electrostatic Discharge

---

**CAUTION**

The power supply has components that can be damaged by ESD (electrostatic discharge). Failure to observe standard, antistatic practices can result in serious degradation of performance, even when an actual failure does not occur.

---

When working on the power supply observe all standard, antistatic work practices. These include, but are not limited to:

- working at a static-free station such as a table covered with static-dissipative laminate or with a conductive table mat (HP P/N 9300-0797, or equivalent).
- using a conductive wrist strap, such as HP P/N 9300-0969 or 9300-0970.
- grounding all metal equipment at the station to a single common ground.
- connecting low-impedance test equipment to static-sensitive components only when those components have power applied to them.
- removing power from the power supply before removing or installing printed circuit boards.



# Verification

---

## Introduction

This chapter provides test procedures for checking the operation of HP Series 668xA power supplies. The required test equipment is specified and sample performance test record sheets are included. Instructions are given for performing the tests either from the front panel or from a controller over the HP-IB.

---

## Tests

Two types of procedures are provided: Operation Verification tests and Performance tests.

Type of Test	Purpose
Operation Verification	These tests do not check all parameters, but comprise a short procedure to verify that the power supply is performing properly.
Performance	These tests verify all the Specifications (not Supplementary Characteristics) listed in Table 1-1 of the Power Supply Operating Manual.

If you encounter failures or out-of-specification test results, see Troubleshooting Procedures (Chapter 3). The procedures will determine if repair and/or calibration is required.

---

**Note** The power supply must pass the selftest at power-on before the following tests can be performed. If the power supply fails selftest, go to Chapter 3.

---



---

## Test Equipment Required

### List of Equipment

Table 2-1 lists the equipment required to perform the tests given in this chapter. Only the equipment marked with the superscript <sup>1</sup> is needed for the Operation Verification test.

### Current-Monitoring Resistor

The four-terminal, current-monitoring resistor (current shunt) listed in Table 2-1 is required to eliminate output current measurement error caused by voltage drops in leads and connections. The specified current shunts have special current-monitoring terminals inside the load connection terminals. The accuracy of the current shunt must be 0.04% or better. When using the 1000 amp 0.05% current shunt the measurement uncertainty should be stated for all calibrations. Connect the current monitor directly to these current-monitoring terminals.

**Table 2-1. Test Equipment Required**

Type	Required Characteristics	Recommended Model
<b>Digital Voltmeter<sup>1</sup></b>	Resolution: 10 nV @ 1V Readout: 8 1/2 digits Accuracy: 20 ppm	HP 3458A
<b>Current Monitor Resistor<sup>1</sup></b>	HP 6682A, 6683A, HP6684A: 0.001Ω ± 0.04%, 300A, 100W  HP 6680A, 6681A 100 μΩ ± 0.05%, 1000A	Guildline 9230/300  Burster Type 1280
<b>DC Power Supply</b>	DC Power Source with current capability equal to UUT	HP 6680A
<b>Electronic Load</b>  <b>Resistor Load</b>	Range: Voltage and current range must exceed that of supply under test. Power: 5.4KW minimum or 5 Kilowatt minimum HP 6680A = 5.7 milliohms 4375W HP 6681A = 13.8 milliohms 4640W HP 6682A = 87.5 milliohms. 5040W HP 6683A = 200 milliohms 5120W HP 6684A = 312 milliohms 5120W	3 each HP 6050A, w/3 each HP 60504B per HP 6050A for all units
<b>Oscilloscope</b>	Sensitivity: 1mV Bandwidth Limit: 20MHz Probe: 1:1 with RF tip	HP 54504A
<b>RMS Voltmeter</b>	True RMS Bandwidth: 20MHz Sensitivity: 100 μV	HP 3400B
<b>Current Transformer</b>	0.1Volt per ampere: 1Hz to 20MHz	Pearson Model 411
<b>Variable-Voltage Transformer (AC Source)</b>	Power: 3 Phase 24KVA; Range: 180-235V 47 - 63Hz; 360- 440V 47 - 63Hz	Superior Powerstat 1156DT-3Y, 0-280V, 50A, 24.2 KVA or equivalent .
<b>HP-IB Controller<sup>2</sup></b>	Full HP-IB capabilities	HP Series 200/300

<sup>1</sup> Required for Operation Verification Tests.

<sup>2</sup> Required for remote testing of 668xA models.

## Electronic Load

Many of the test procedures require the use of a variable load capable of dissipating the required power. If a variable resistor is used, switches must be used for connecting, disconnecting, and shorting the load resistor. For most tests, an electronic load (see Table 2-1) is easier to use than a variable resistor. However, an electronic load may not be fast enough for testing transient recovery time or may be too noisy for testing noise (PARD). In these cases, fixed load resistors of suitable power dissipation can be used with minor changes to the test procedures given in this chapter.

---

## Programming The Tests

### General Considerations

Procedures are given for programming these tests either from the front panel keypad or from an HP-IB controller. The procedures assume you know how to use the front panel keypad or how to program over the HP-IB (see the Power Supply Operating Manual for more information). When using computer-controlled tests, you may have to consider the relatively slow (compared to computer and system voltmeters) settling times and slew rates of the power supply. Suitable WAIT statements can be inserted into the test program to give the power supply time to respond to the test commands.

**WARNING**

This power supply can provide more than 240VA at more than 2 volts. If the output connections touch each other, severe arcing can occur resulting in burns, ignition or welding of parts. DO NOT ATTEMPT TO MAKE CONNECTIONS WHILE OUTPUT POWER IS ON. These connections should be performed only by qualified electronics personnel.

---

### Programming Parameters

Table 2-2 lists the programming voltage and current values for each model. You can enter these values either from the front panel or from a controller over the HP-IB.

**Table 2-2. Programming Voltage and Current Values**

HP Model	Full Scale Voltage	Max. Prog. Voltage	Full Scale Current	Max. Prog. Current	Max. Prog. Overvoltage
HP 6680A	5V	5.125V	875A	895A	6.25V
HP 6681A	8V	8.190V	580A	592A	10.0V
HP 6682A	21V	21.50V	240A	246A	25.2V
HP 6683A	32V	32.75V	160A	164A	38.4V
HP 6684A	40V	41.00V	128A	131A	48.0V

---

### General Measurement Techniques

Figure 2-1 shows the setup for the Constant Voltage tests. Measure the dc output voltage directly at the sense (+S and -S) terminals. Connect these terminals for remote sensing (to the +S and -S terminals). Connect these terminals for local sensing. Be certain to use load leads of sufficient wire gauge to carry the output current (see Chapter 4 of the Power Supply Operating Manual). To avoid noise pickup, use coaxial cable or shielded pairs for the test leads. If you use more than one meter or a meter and an oscilloscope, connect separate leads for each instrument to avoid mutual-coupling effects.

---

### Performance Test Record Sheets

When performing the tests in this chapter, refer to the Performance Test Record sheets supplied at the end of this chapter. Table 2-6 is for recording common information, such as, the test equipment used and the environmental conditions. Tables 2-7 through 2-11 are dedicated to specific models. Each sheet lists the acceptable test ranges for the model and provides a place to record the results of the test.

---

**Note**

It is recommended that before you perform the tests in either Table 2-4 or Table 2-5, that you first locate the appropriate Performance Test Record sheet from Tables 2-7 through Table 2-11 for your specific model. Make a copy of this sheet, and record the actual observed values in it while performing the tests. Use the sheets in Tables 2-7 through Table 2-11 as master reference sheets to run copies at any time.

---

---

**Operation Verification Tests**

Table 2-3 lists the requirements for operation verification, which is a subset of the performance tests.

**Table 2-3. Operation Verification Tests**

	<b>Test</b>	<b>Refer To</b>
1	Turn-On Checkout	Power Supply Operating Manual
2	Voltage Programming and Readback Accuracy	Table 2-4
3	Current Programming and Readback Accuracy	Table 2-5

Note: Record the results of Tests 2 and 3 in the appropriate Performance Test Record sheets

---

**Performance Tests**

Performance tests check all the specifications of the power supply. The tests are grouped into constant-voltage mode tests (Table 2-4) and constant-current mode tests (Table 2-5).

**Constant Voltage (CV) Tests****Test Setup**

Connect your dc voltmeter leads to only +S and -S (see Figure 2-1), because the power supply regulates the voltage between these points, not between the + and - output terminals .

**Test Procedures**

Perform the test procedures in Table 2-4. The CV tests are:

- Voltage Programming and Readback Accuracy
- CV Load Effect
- CV Source Effect
- CV Noise (PARD)
- Transient Recovery Time

---

**Note**

The tests are independent and may be performed in any order.

---

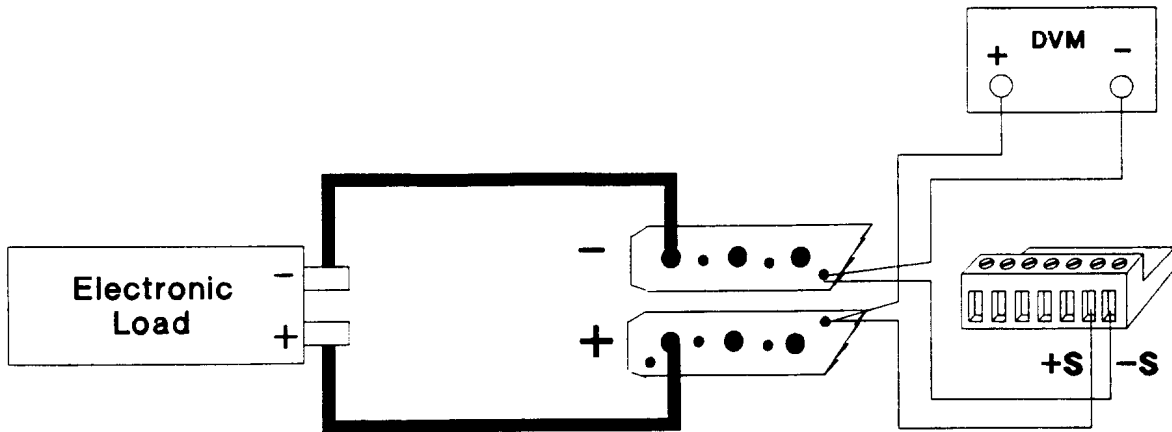

a) CV Test Setup with 5KW Electronic Load

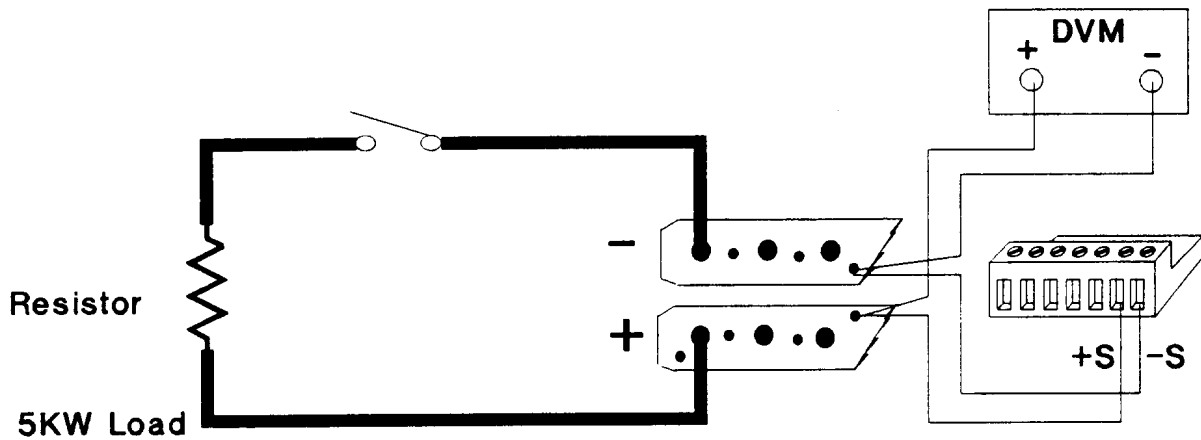

b) CV Test Setup with 5KW Load Resistor

Note: Start with switch closed, take full load reading, open switch and take no load reading.

Figure 2-1. Constant Voltage (CV) Test Setup

**Table 2-4. Constant Voltage (CV) Tests**

	<b>Action</b>	<b>Normal Result</b>
<b>Voltage Programming and Readback Accuracy</b>		
<p>This test verifies that the voltage programming, HP-IB readback (HP-IB system power supplies only), and front panel display functions are within specifications. With system power supplies, values read back over the HP-IB should be the same as those displayed on the front panel.</p>		
1	Turn off the power supply and connect a DVM across +S and -S (see Fig. 2-1).	
2	Turn on the power supply with no load and program the output for 0 volts and maximum programmable current (see Table 2-2).	<b>CV</b> annunciator on. Output current near 0.
3	Record voltage readings at DVM and on front panel display	Readings within specified Low Voltage limits.
4	Program voltage to full scale (see Table 2-2)	
5	Record voltage readings of DVM and on front panel display	Readings within specified High Voltage limits.
<b>CV Load Effect</b>		
<p>This test measures the change in output voltage resulting from a change in output current from full-load to no-load.</p>		
1	Turn off the power supply and connect a DVM across +S and -S (see Fig. 2-1).	
2	Turn on the power supply and program the current to its maximum programmable value and the voltage to its full-scale value (see Table 2-2).	
3	Adjust the load to produce full-scale current (see Table 2-2) as shown on the front panel display.	CV annunciator is on. If it is not, adjust the load to slightly reduce the output current until the annunciator comes on.
4	Record voltage reading of the DVM.	
5	Adjust load to draw 0 amperes (open load). Record voltage reading of the DVM.	
6	Check test result.	The difference between the DVM readings in steps 4 and 5 are within the specified Load Effect limits.
<b>CV Source Effect</b>		
<p>This test measures the change in output voltage resulting from a change in ac line voltage from its minimum to maximum value within the line voltage specifications.</p>		
1	Turn off the power supply and connect the ac power input through a variable-voltage transformer.	



**Table 2-4. Constant Voltage (CV) Tests (continued)**

	Action	Normal Result
<b>CV Source Effect (cont)</b>		
2	Set the transformer to the nominal ac line voltage. Connect the DVM across +S and -S (see Fig. 2-1).	
3	Turn on the power supply and program the current to its maximum programmable value and the voltage to its full-scale value (see Table 2-2).	
4	Adjust the load to produce full-scale current (see Table 2-2) as shown on the front panel display.	<b>CV</b> annunciator is on. If it is not, adjust the load to slightly reduce the output current until the annunciator comes on.
5	Adjust the transformer to decrease the ac input voltage to the low- line condition (174Vac or 191Vac). Record the output voltage reading of the DVM.	
6	Adjust the transformer to increase the ac input voltage to the high-line condition (220Vac or 250Vac). Record the output voltage reading on the DVM.	
7	Check test result.	The difference between the DVM readings in steps 5 and 6 are within the specified Source Effect limits.
<b>CV Noise (PARD)</b>		
Periodic and random deviations (PARD) in the output (ripple and noise) combine to produce a residual ac voltage superimposed on the dc output voltage. This test measures CV PARD, specified as the rms and peak-to-peak output voltages over the frequency range of 20Hz to 20MHz.		
1	Turn off the power supply and connect an a-c coupled oscilloscope across the + and -output terminals (see Fig. 2-1). Set the oscilloscope bandwidth limit to 20MHz (30MHz for the HP 54504A) and use an RF tip on the oscilloscope probe.	
2	Turn on the power supply and program the current to its maximum programmable value and the voltage to its full-scale value (see Table 2-2).	
3	Adjust the load to produce full-scale current (see Table 2-2) as shown on the front panel display.	<b>CV</b> annunciator is on. If it is not, adjust the load to slightly reduce the output current until the annunciator comes on.
4	Record the amplitude of the waveform.	Amplitude is within the specified PARD Peak-to-Peak limits.
5	Replace the oscilloscope connection with an ac rms voltmeter.	
6	Record the reading obtained in Step 5.	Amplitude is within the specified PARD rms limits.

**Table 2-4. Constant Voltage (CV) Tests (continued)**

	Action	Normal Result
<b>Transient Recovery Time</b>		
<p>This test measures the time required for the output voltage to return to within 100mV of its final value following a 50% change in output load current. Measurements are made on both the unloading transient (from full load to 1/2 load) and the loading transient (from 1/2 load to full load).</p>		
1	Turn off the power supply and connect an oscilloscope across +S and -S (see Fig. 2-1).	
2	Turn on the power supply and program the current to its maximum programmable value and the voltage to its full-scale value (see Table 2-2).	
3	Program the Electronic Load as follows: <ul style="list-style-type: none"> <li>⌋ Operating mode to constant current</li> <li>⌋ Input load current to 1/2 the supply's full rated output current</li> <li>⌋ Transient current level to the supply's full rated output current</li> <li>⌋ Transient generator frequency = 100Hz</li> <li>⌋ Transient generator duty cycle = 50%</li> </ul>	
4	Turn on the transient and adjust the oscilloscope to display response waveform.	See Fig. 2-2.
5	Measure both the loading and unloading transients by triggering the oscilloscope on both the negative and positive slopes of the transient. Record the voltage level obtained at the 900- $\mu$ s interval .	Specified voltage level is reached within 900 $\mu$ s.

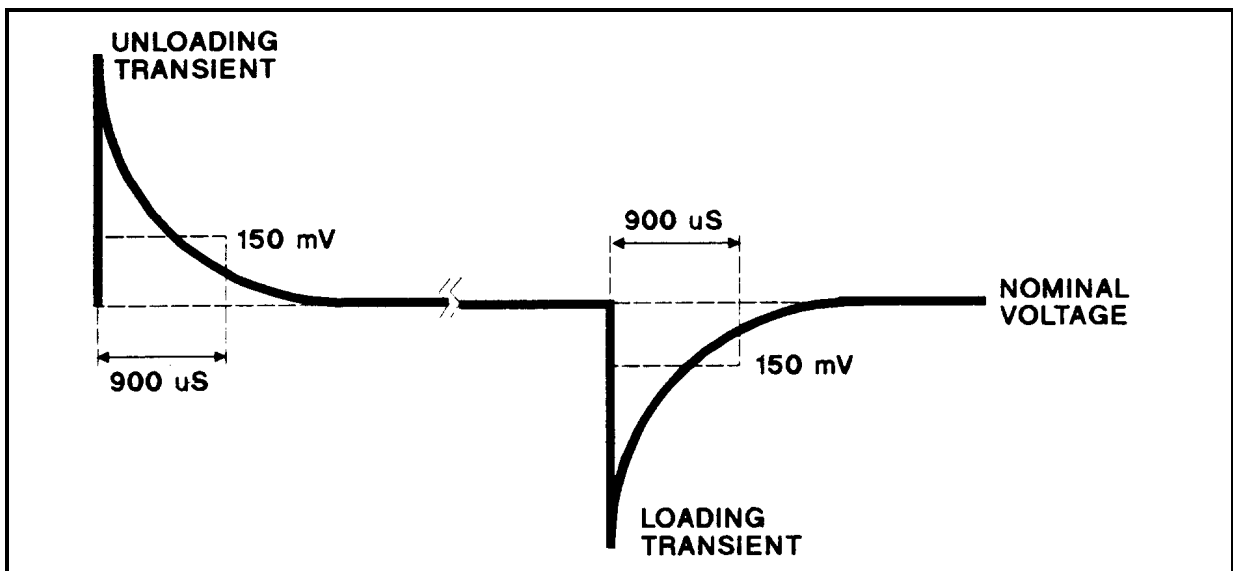

Figure 2-2. Transient Response Waveform

## Constant Current (CC) Tests

### Test Setup

Connect the appropriate current monitoring resistor (see Table 2-1) as shown in Fig. 2-3. The accuracy of the resistor must be as specified in the table.

### Test Procedures

The test procedures are given in Table 2-5. The tests are independent and may be performed in any order. The CC tests are:

- Current Programming and Readback Accuracy
- CC Load Effect
- CC Source Effect
- CC Noise (PARD)

**Table 2-5. Constant Current (CC) Tests**

	Action	Normal Result
<b>Current Programming and Readback Accuracy</b>		
This test verifies that the current programming and readback are within specification.		
1	Turn off the power supply and connect the current monitoring resistor as shown in Fig. 2-3. Connect a DVM across the resistor .	
2	Turn on the power supply and program the output for 5 volts and 0 amperes.	
3	Short the load.	
4	Observe the DVM voltage reading. Divide this by the resistance of the current monitor resistor. Record the result as the Low Current value.	Value within specified Low Current limits.
5	Record the front panel display readback.	Value within specified readback limits.
6	Program output current to full scale (see Table 2-2).	
7	Repeat Steps 4 and 5.	Both current readings within specified High Current and readback limits.
<b>CC Noise (PARD)</b>		
Periodic and random deviations (PARD) in the output (ripple and noise) combine to produce a residual ac current superimposed on the dc output current. This test measures CC PARD, specified as the rms output current over the frequency range of 20 Hz to 20 MHz.		
1	Turn off the power supply and connect the current transformer, resistor, capacitor and rms voltmeter (see Fig. 2-4).	

**Table 2-5. Constant Current (CC) Tests (continued)**

	<b>Action</b>	<b>Normal Result</b>
<b>CC Noise (PARD) (cont)</b>		
2	Measure the residual noise on the DVM with the power supply turned off. Noise generated by other equipment may affect this measurement and should be removed or factored out.	
3	Turn on the power supply and program the current to its full scale value and the voltage to its maximum programmable value (see Table 2-2).	
4	Adjust the load in the CV mode for full-scale voltage (see Table 2-2) as shown on the front panel display.	The power supply output current should be at its full-scale value and the <b>CC</b> annunciator on. If it is not, adjust the load to slightly reduce the output voltage until the annunciator comes on.
5	Observe the reading on the rms voltmeter. Multiply rms voltage by 0.1 to obtain the rms noise current.	Current is within the specified PARD rms limits (see Table 2-6).
<b>CC Load Effect</b>		
<p>This test measures the change in output current resulting from a change in load from full-load voltage to a short circuit. It is recommended that you use averaged readings for Steps 5 and 6 of this test (see Averaging AC Measurements at the end of this chapter).</p> <p><b>Note:</b> Refer to Figure 2-4. If you are using HP 60504B Eloads, a series DC power source is required to supply the minimum 3 volt input required by the HP 60504B Eloads. The series DC source must be capable of 3VDC at a current level greater than the output current of the supply being tested. A switch can be used in place of the series supply if the Eloads are used in place of a load resistor as shown in Fig. 2-4(b).</p>		
1	Turn off the power supply and connect a DVM across the current monitoring resistor (see Fig. 2-3).	
2	Turn on the power supply and program the current to its full scale value and the voltage to its maximum programmable value (see Table 2-2).	
3	Set the Electronic Load to CV mode and its voltage to full scale as indicated on its front panel display. Set the series supply for 3VDC and a current greater than that being tested. Series source should be in CV mode.	Power supply output current is full scale and its <b>CC</b> annunciator is on. If not, reduce the Electronic Load voltage slightly until the annunciator comes on.
4	Observe the DVM reading. Divide this by the resistance of the current monitoring resistor to obtain the output current. Record the result.	You may want to use an averaged reading for this measurement.
5	Program the Electronic Load input to 3 volts or short the Electronic Load input and repeat Step 5.	You may want to use averaged reading for this measurement.
6	Check the result.	The difference between the current readings taken in Step 5 and Step 6 must be within specified "Load Effect" limits (see Table 2-2).

**Table 2-5. Constant Current (CC) Tests (continued)**

	Action	Normal Result
<b>CC Source Effect</b>		
<p>This test measures the change in output current resulting from a change in ac line voltage from its minimum to its maximum value within the line voltage specifications. It is recommended that you use averaged readings for Steps 6 and 8 of this test (see "Averaging AC Measurements" at the end of this chapter) .</p>		
1	Turn off the power supply and connect the ac power input through a variable-voltage transformer.	
2	Set the transformer to the nominal ac line voltage. Connect the DVM across the current monitoring resistor (see Fig. 2-3).	
3	Turn on the power supply and program the current to its full-scale value and the voltage to its maximum programmable value (see Table 2-2).	
4	Set the Electronic Load to CV mode and its voltage to full scale.	
5	Adjust the transformer to decrease the ac input voltage to the low-line condition (180Vac or 360Vac).	<p>The power supply output current is full scale and its <b>CC</b> annunciator is on. If not, reduce the Electronic Load voltage slightly until the annunciator comes on.</p>
6	Observe the DVM reading. Divide this voltage by the resistance of the current monitoring resistor to obtain the output current. Record the result.	You may want to use an averaged reading for this measurement.
7	Adjust the transformer to increase the ac input voltage to the high-line condition (235Vac or 440Vac).	
8	Observe the DVM reading. Divide this voltage by the resistance of the current monitoring resistor to obtain the output current. Record the result.	You may want to use an averaged reading for this measurement.
9	Check the test result.	The difference between the current readings found in Step 6 and Step 8 is within the specified current Source Effect limits.

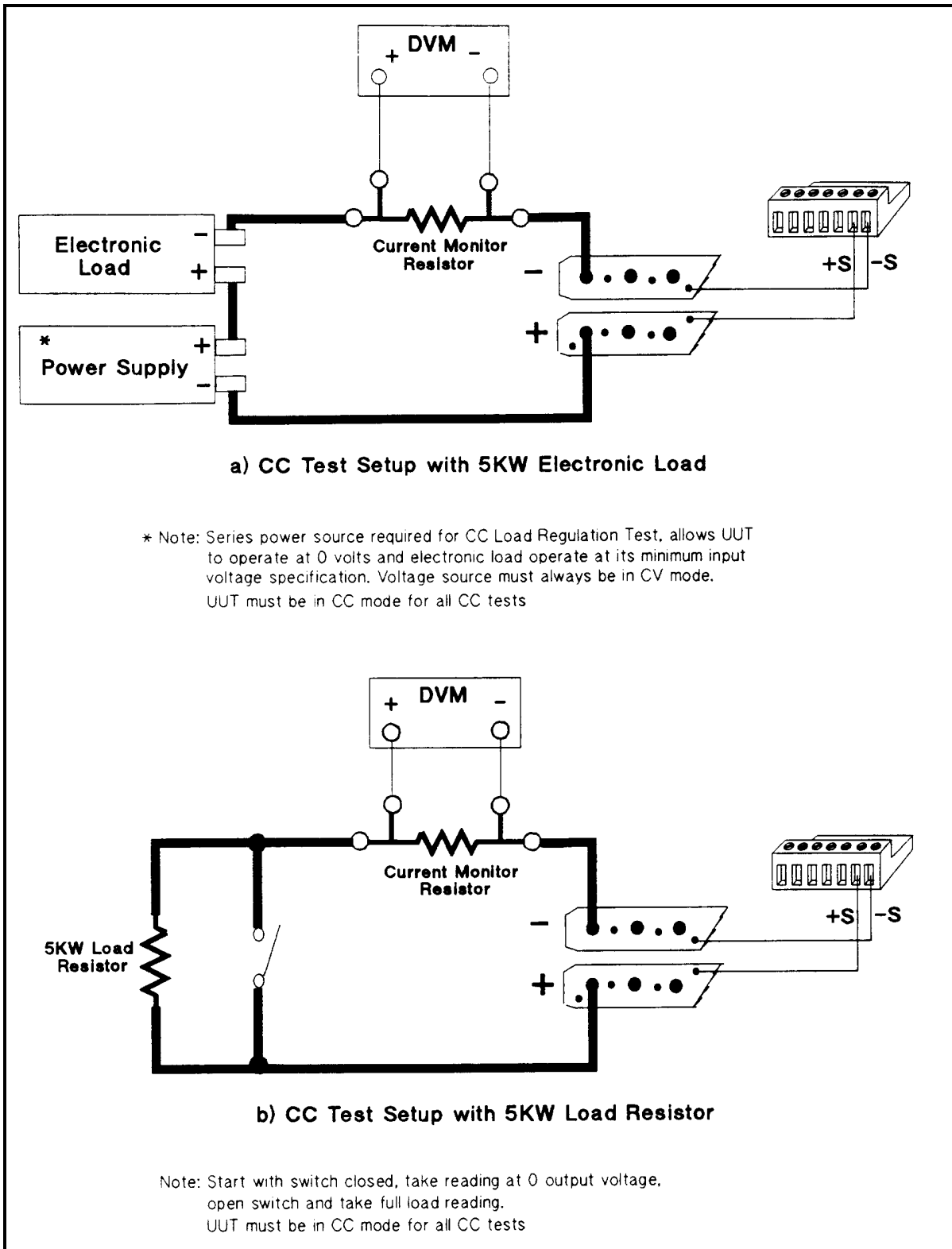
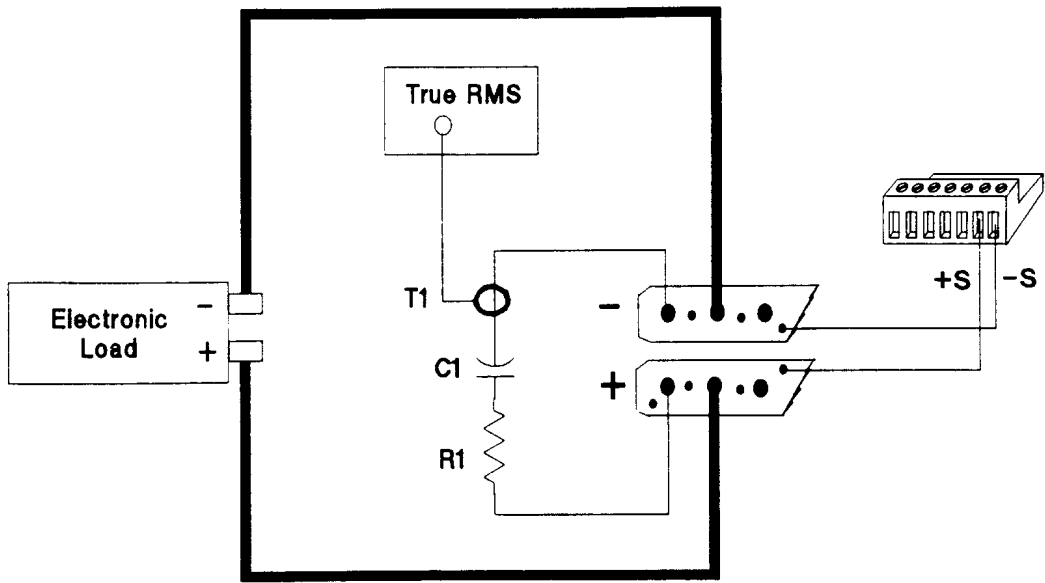

Figure 2-3. CC Load Effect Test Setup



	R1	C1	R1 / C1 construction
6680A	4.0 milliohms	132,000 uF	4 * 33,000uF ( 0180-4516 ) + 2 ea. 7 inch 12 AWG leads
6681A	6.0 milliohms	88,000 uF	4 * 22,000 uF ( 0180-4532 ) + 2 ea. 7 inch 14 AWG leads
6682A	4.42 milliohms	36,000 uF	5 * 7200 uF ( 0180-4597 ) + 2 ea. 8 inch 10 AWG leads
6683A	6.12 milliohms	26,000 uF	2 * 13,000 uF ( 0180-4596 ) + 2 ea. 6 inch 10 AWG leads
6684A	11.1 milliohms	14,400 uF	2 * 7200 uF ( 0180-4597 ) + 2 ea. 11 inch 14 AWG leads

1. T1 = Pearson Type 411 ( see Table 2-1 ).
2. R1 = ESR of capacitor + wire lead resistance.
3. Parallel capacitor connections should be made with copper sheet and wire leads should be soldered to copper sheet to reduce series resistance.
4. Fixed load resistor may be used in place of electronic load.
5. Electronic load consists of: 11-60504Bs in CC mode and 1-60504B in CR mode for the 6680A / 6681A.  
12-60504Bs in CR mode for the 6682A / 6683A / 6684A.





Figure 2-4. CC rms Noise Test Setup

## Averaging the CC Measurements

The CC Load Effect and CC Source Effect tests measure the dc regulation of the power supply's output current. When doing these tests, you must be sure that the readings taken are truly dc regulation values and not instantaneous ac peaks of the output current ripple. You can do this by making each measurement several times and then using the average of the measurements as your test value. Voltmeters such as the HP 3458A System Voltmeter can be programmed to take just such statistical average readings as required by these tests.

The following steps show how to set up the voltmeter from its front panel to take a statistical average of 100 readings.

 represents the unlabeled shift key in the FUNCTION/RANGE group.

1. Program 10 power line cycles per sample by pressing **NPLC** **1** **0** **Enter**.
2. Program 100 samples per trigger by pressing **N Rds/Trig** **1** **0** **0** **Enter**.
3. Set up voltmeter to take measurements in the statistical mode as follows:
  - a. Press  **f0**  **N**.
  - b. Press **▲** until MATH function is selected, then press **▶**.
  - c. Press **▲** until STAT function is selected, then press **Enter**.
4. Now set up voltmeter to read the average of the measurements as follows:
  - a. Press  **f1**  **N**.
  - b. Press **▼** until RMATH function is selected, then press **Enter**.
  - c. Press **▲** until MEAN function is selected, then press **Enter**.
5. Execute the average reading program by pressing **f0** **Enter** **TRIG** **Enter**.
6. Wait for 100 readings and then read the average measurement by pressing **f1** **Enter**.

Record this as your result.



**Table 2-6. Performance Test Record Form**

**Test Facility:**

_____	Report No. _____
_____	Date _____
_____	Customer _____
_____	Tested By _____
Model _____	Ambient Temperature (°C) _____
Serial No. _____	Relative Humidity (%) _____
Options _____	Nominal Line Frequency (Hz) _____
Firmware Revision _____	

**Special Notes:**

\_\_\_\_\_

\_\_\_\_\_

\_\_\_\_\_

\_\_\_\_\_

\_\_\_\_\_

\_\_\_\_\_

\_\_\_\_\_

\_\_\_\_\_

**Test Equipment Used:**

<b>Description</b>	<b>Model No.</b>	<b>Trace No.</b>	<b>Cal. Due Date</b>
1. AC Source	_____	_____	_____
2. DC Voltmeter	_____	_____	_____
3. RMS Voltmeter	_____	_____	_____
4. Oscilloscope	_____	_____	_____
5. Electronic Load	_____	_____	_____
6. Current Monitoring Shunt	_____	_____	_____

Table 2-7. Performance Test Record for HP Model 6680A

MODEL HP _____	Report No. _____		Date _____	
Test Description	Minimum Spec.	Results *	Maximum Spec.	Measurement Uncertainty
<b>Constant Voltage Tests</b>				
<b>Voltage Programming and Readback</b>				
Low Voltage (0V) $V_{out}$ Front Panel Display Readback	-5mV $V_{out} - 7.5mV$	_____mV _____mV	+5mV $V_{out} + 7.5mV$	1.6 $\mu V$ 1.6 $\mu V$
High Voltage (5V) $V_{out}$ Front Panel Display Readback	4.993V $V_{out} - 10mV$	_____V _____mV	5.007V $V_{out} + 10mV$	56 $\mu V$ 56 $\mu V$
<b>Load Effect</b>	$V_{out} - 0.3mV$	_____mV	$V_{out} + 0.3mV$	750 nV
<b>Source Effect</b>	$V_{out} - 0.3mV$	_____mV	$V_{out} + 0.3mV$	750 nV
<b>PARD (Ripple and Noise)</b>				
Peak-to-Peak	0	_____mV	10mV	904 $\mu V$
RMS	0	_____mV	1.5mV	150 $\mu V$
<b>Transient Response Time (at 900 <math>\mu s</math>)</b>	0	_____mV	150mV	23mV
<b>Constant Current Tests</b>				
<b>Current Programming and Readback</b>				
Low Current (0A) $I_{out}$ Front Panel Display Readback	-450mA $I_{out} - 600mA$	_____mA _____mA	+450mA $I_{out} + 600mA$	15 $\mu A$ 15 $\mu A$
High Current (875A) $I_{out}$ Front Panel Display Readback	873.675A $I_{out} - 1.475mA$	_____A _____mA	+876.325A $I_{out} + 1.475mA$	462mA 462mA
<b>PARD (Ripple and Noise) RMS</b>	0	_____mA	290mA	3.8mA
<b>Load Effect</b>	$I_{out} - 108mA$	_____mA	$I_{out} + 108mA$	937 $\mu A$
<b>Source Effect</b>	$I_{out} - 108mA$	_____mA	$I_{out} + 108mA$	937 $\mu A$
*Enter your test results in this column.				

Table 2-7. Performance Test Record for HP Model 6681A

MODEL HP _____	Report No. _____		Date _____	
Test Description	Minimum Spec.	Results *	Maximum Spec.	Measurement Uncertainty
<b>Constant Voltage Tests</b>				
<b>Voltage Programming and Readback</b>				
Low Voltage (0V) $V_{out}$ Front Panel Display Readback	-8mV $V_{out} - 12mV$	_____mV _____mV	+8mV $V_{out} + 12mV$	1.6 $\mu V$ 1.6 $\mu V$
High Voltage (8V) $V_{out}$ Front Panel Display Readback	7.988V $V_{out} - 16mV$	_____V _____mV	8.011V $V_{out} + 16mV$	88 $\mu V$ 88 $\mu V$
<b>Load Effect</b>	$V_{out} - 0.5mV$	_____mV	$V_{out} + 0.5mV$	900 nV
<b>Source Effect</b>	$V_{out} - 0.5mV$	_____mV	$V_{out} + 0.5mV$	900 nV
<b>PARD (Ripple and Noise)</b>				
Peak-to-Peak	0	_____mV	10mV	904 $\mu V$
RMS	0	_____mV	1.5 mV	150 $\mu V$
<b>Transient Response Time (at 900 <math>\mu s</math>)</b>	0	_____mV	150mV	23mV
<b>Constant Current Tests</b>				
<b>Current Programming and Readback</b>				
Low Current (0A) $I_{out}$ Front Panel Display Readback	-300mA $I_{out} - 400mA$	_____mA _____mA	+300mA $I_{out} + 400mA$	15mA 15mA
High Current (580A) $I_{out}$ Front Panel Display Readback	579.120A $I_{out} - 980mA$	_____A _____A	+580.880A $I_{out} + 980mA$	311mA 311mA
<b>PARD (Ripple and Noise)</b>				
RMS	0	_____mA	190mA	3.8mA
<b>Load Effect</b>	$I_{out} - 69mA$	_____mA	$I_{out} + 69mA$	790 $\mu A$
<b>Source Effect</b>	$I_{out} - 69mA$	_____mA	$I_{out} + 69mA$	790 $\mu A$
*Enter your test results in this column.				

Table 2-7. Performance Test Record for HP Model 6682A

MODEL HP _____	Report No. _____		Date _____	
Test Description	Minimum Spec.	Results *	Maximum Spec.	Measurement Uncertainty
<b>Constant Voltage Tests</b>				
<b>Voltage Programming and Readback</b>				
Low Voltage (0V) $V_{out}$ Front Panel Display Readback	-21mV $V_{out} - 32mV$	_____mV _____mV	+21mV $V_{out} + 32mV$	1.7 $\mu V$ 1.7 $\mu V$
High Voltage (21V) $V_{out}$ Front Panel Display Readback	20.970V $V_{out} - 42mV$	_____V _____mV	21.029V $V_{out} + 42mV$	347 $\mu V$ 347 $\mu V$
<b>Load Effect</b>	$V_{out} - 1mV$	_____mV	$V_{out} + 1mV$	20 $\mu V$
<b>Source Effect</b>	$V_{out} - 1mV$	_____mV	$V_{out} + 1mV$	20 $\mu V$
<b>PARD (Ripple and Noise)</b>				
Peak-to-Peak	0	_____mV	10mV	904 $\mu V$
RMS	0	_____mV	1.75 mV	150 $\mu V$
<b>Transient Response Time (at 900 <math>\mu s</math>)</b>	0	_____mV	150mV	23 $\mu V$
<b>Constant Current Tests</b>				
<b>Current Programming and Readback</b>				
Low Current (0A) $I_{out}$ Front Panel Display Readback	-125mA $I_{out} - 165mA$	_____mA _____mA	+125mA $I_{out} + 165mA$	1.5mA 1.5mA
High Current (240A) $I_{out}$ Front Panel Display Readback	239.635A $I_{out} - 405mA$	_____A _____mA	+240.365A $I_{out} + 405mA$	84mA 84mA
<b>PARD (Ripple and Noise)</b>				
RMS	0	_____mA	80mA	0.8mA
<b>Load Effect</b>	$I_{out} - 24mA$	_____mA	$I_{out} + 24mA$	172 $\mu A$
<b>Source Effect</b>	$I_{out} - 24mA$	_____mA	$I_{out} + 24mA$	172 $\mu A$
*Enter your test results in this column.				

Table 2-7. Performance Test Record for HP Model 6683A

MODEL HP _____	Report No. _____		Date _____	
Test Description	Minimum Spec.	Results *	Maximum Spec.	Measurement Uncertainty
<b>Constant Voltage Tests</b>				
<b>Voltage Programming and Readback</b>				
Low Voltage (0V) $V_{out}$ Front Panel Display Readback	-32mV $V_{out} - 48mV$	_____mV _____mV	+32mV $V_{out} + 48mV$	1.9 $\mu V$ 1.9 $\mu V$
High Voltage (32V) $V_{out}$ Front Panel Display Readback	31.995V $V_{out} - 64mV$	_____V _____mV	32.044V $V_{out} + 64mV$	488 $\mu V$ 488 $\mu V$
<b>Load Effect</b>	$V_{out} - 1.7mV$	_____mV	$V_{out} + 1.7mV$	26 $\mu V$
<b>Source Effect</b>	$V_{out} - 1.7mV$	_____mV	$V_{out} + 1.7mV$	26 $\mu V$
<b>PARD (Ripple and Noise)</b>				
Peak-to-Peak	0	_____mV	10mV	904 $\mu V$
RMS	0	_____mV	2.0mV	150 $\mu V$
<b>Transient Response Time (at 900 <math>\mu s</math>)</b>	0	_____mV	150mV	23 $\mu V$
<b>Constant Current Tests</b>				
<b>Current Programming and Readback</b>				
Low Current (0A) $I_{out}$ Front Panel Display Readback	-85mA $I_{out} - 110mA$	_____mA _____mA	+85mA $I_{out} + 110mA$	1.5mA 1.5mA
High Current (160A) $I_{out}$ Front Panel Display Readback	159.755A $I_{out} - 270mA$	_____A _____mA	+160.245A $I_{out} + 270mA$	36mA 36mA
<b>PARD (Ripple and Noise) RMS</b>	0	_____mA	55mA	0.56mA
<b>Load Effect</b>	$I_{out} - 18mA$	_____mA	$I_{out} + 18mA$	148 $\mu A$
<b>Source Effect</b>	$I_{out} - 18mA$	_____mA	$I_{out} + 18mA$	148 $\mu A$
*Enter your test results in this column.				

Table 2-7. Performance Test Record for HP Model 6684A

MODEL HP _____	Report No. _____		Date _____	
Test Description	Minimum Spec.	Results *	Maximum Spec.	Measurement Uncertainty
<b>Constant Voltage Tests</b>				
<b>Voltage Programming and Readback</b>				
Low Voltage (0V) $V_{out}$ Front Panel Display Readback	-40mV $V_{out} - 60mV$	_____mV _____mV	+40mV $V_{out} + 60mV$	2 $\mu V$ 2 $\mu V$
High Voltage (40V) $V_{out}$ Front Panel Display Readback	39.944V $V_{out} - 80mV$	_____V _____mV	40.056V $V_{out} + 80mV$	590 $\mu V$ 590 $\mu V$
<b>Load Effect</b>	$V_{out} - 2.3mV$	_____mV	$V_{out} + 2.3mV$	30 $\mu V$
<b>Source Effect</b>	$V_{out} - 2.3mV$	_____mV	$V_{out} + 2.3mV$	30 $\mu V$
<b>PARD (Ripple and Noise)</b>				
Peak-to-Peak	0	_____mV	10mV	904 $\mu V$
RMS	0	_____mV	2.5mV	150 $\mu V$
<b>Transient Response Time (at 900 <math>\mu s</math>)</b>	0	_____mV	150mV	23 $\mu V$
<b>Constant Current Tests</b>				
<b>Current Programming and Readback</b>				
Low Current (0A) $I_{out}$ Front Panel Display Readback	-65mA $I_{out} - 90mA$	_____mA _____mA	+65mA $I_{out} + 90mA$	1.5mA 1.5mA
High Current (128A) $I_{out}$ Front Panel Display Readback	127.807A $I_{out} - 218mA$	_____A _____mA	+128.193A $I_{out} + 218mA$	24mA 24mA
<b>PARD (Ripple and Noise)</b>	0	_____mA	45mA	0.23mA
RMS				
<b>Load Effect</b>	$I_{out} - 15mA$	_____mA	$I_{out} + 15mA$	138mA
<b>Source Effect</b>	$I_{out} - 15mA$	_____mA	$I_{out} + 15mA$	138mA
*Enter your test results in this column.				







# Troubleshooting

**WARNING**

**Shock Hazard:** Most of the procedures in this chapter must be performed with power applied and protective covers removed. These procedures should be done only by trained service personnel aware of the hazard from electrical shock.

**CAUTION**

This instrument uses components that can be damaged or suffer serious performance degradation due to ESD (electrostatic discharge). Observe standard antistatic precautions to avoid damage to the components (see Chapter 1).

## Introduction

### Localizing the Problem

This chapter provides troubleshooting and repair information for the power supply. Before beginning troubleshooting procedures, make certain the problem is in the power supply and not with an associated circuit, the HP-IB controller (for HP-IB system power supplies), or ac input line. Without removing the covers, you can use the Verification tests in Chapter 2 to determine if the power supply is operating normally.

### Chapter Organization

The information in this chapter is organized as follows:

Topic	Information Given
Test Equipment Required	Equipment required for completing all the tests in this chapter.
Troubleshooting Procedures	<p>A series of flow charts for systematic location of defective boards, circuits, and components. An explanation of the error codes and messages generated during the power-on selftest. Signature analysis techniques for troubleshooting the digital circuits on the front panel, primary HP-IB, and secondary interface circuits. Specific paragraphs for:</p> <ul style="list-style-type: none"> <li>• Checking the bias and reference supplies.</li> <li>• Troubleshooting the CV/CC status annunciators.</li> <li>• Troubleshooting the A3 FET board.</li> </ul>
Post-Repair Adjustments	Calibration and EEPROM initialization procedures required after the replacement of certain critical components.
Disassembly Procedures	Gaining access to and/or replacing components.

---

## Test Equipment Required

**Table 3-1. Test Equipment Required**

Equipment	Purpose	Recommended Model
Logic Probe	To check states of data lines.	HP 545A
Test Clips	To gain access to IC pins.	AP Products No. LTC
Ammeter/Current Shunt	To measure output current.	HP 6680A & 6681A: Burster 1280 HP 6682A, 6683A & 6684A: Guildline 9230/300
Oscilloscope	To check waveforms and signal levels.	HP 54504A
Signature Analyzer	To troubleshoot most of the primary and secondary interface circuits.	HP 5005A/B
HP-IB Controller	To communicate with power supply via the HP-IB (for system units).	HP BASIC series
DC Voltmeter	To measure output voltage and current, bias and references.	HP 3458A

---

## Troubleshooting Procedures

### Power-On Selftest

#### Description

The procedures in the troubleshooting charts make use of the power-on selftest. The power-on selftest tests the front panel, HP-IB interface (for HP-IB system power supplies), and secondary interface circuits. If the power supply fails the selftest, the output remains disabled (turned off) and the front panel normally displays an error code or message (see Table 3-2). The message is displayed indefinitely and the power supply will not accept HP-IB or front panel commands.

#### Disabling The Power-On Selftest

In order to perform troubleshooting procedures that require programming of the power supply, you must disable the power-on self test. Do this as follows:

1. Turn off the power supply.
2. Hold down the **7** key and turn on the supply.
3. Continue holding down the **7** for 2 seconds and wait until the **PWR ON INIT** indicator goes off.
4. The power supply is now on without executing power-on selftest.

#### Using the \*TST? Query (HP-IB Systems Supplies Only)

You can get the power supply to execute a partial selftest by sending it the HP-IB \*TST? query command. Table 3-2 shows the tests that are performed in response to this command. These tests do not interfere with normal operation or cause the output to change. The command returns a value of "0" if all tests pass. Otherwise, the command returns the error code of the first test that failed. No error codes are displayed on the front panel and the power supply will attempt to continue normal operation.

**Table 3-2. Selftest Error Codes/Messages**

<b>Code and/or Message</b>	<b>Description</b>	<b>Probable Cause Selftest Error Codes/Messages</b>
E1 FP RAM	Front panel RAM test failed (power-on).	Microprocessor AIU3
E2 FP ROM	Front panel ROM test failed (power-on and *TST?).	ROM AIU4 or address latches AIU8
E3 EE CHKSM	Front panel EEPROM checksum test failed (power-on and *TST?).	Possibly due to power loss during a write operation. See Checksum Errors in Chapter 3 of Operating Manual. If power loss is not the problem, EEPROM AIU6 could be defective. (If you replace AIU6, the power supply must be reinitialized and calibrated.)
E4 PRI XRAM	Primary interface external RAM test failed (power-on).	RAM A2U108
E5 PRI IRAM	Primary interface internal RAM test failed (power-on).	Microprocessor A2U114
E6 PRI ROM	Primary interface ROM test failed (power-on and *TST?).	ROM A2U106
E7 HP-IB	HP-IB interface test failed (power-on).	Talker/listener A2U117
E8 SEC RAM	Secondary interface RAM test failed (power-on).	Microprocessor AI0U506
E9 SEC ROM	Secondary interface ROM test failed (power-on and *TST?).	Microprocessor AI0U506
E10 SEC 5V	Secondary interface 5 volt readback test failed (power-on and *TST?).	Comparators AI0U516, AI0U517 readback DAC AI0U512/U515, or secondary bias supply (5Vs A4U304)
E11 TEMP	Ambient temperature readback test failed (power-on and *TST?).	Thermistor AI0RT500 or comparator AI0U517
E12 DACS	CV or CC DAC tests failed (power-on).	CV DAC AI0U510/U513 or CC DAC AI0U511/U514 (see Figure 3-7).
<b>NOTE:</b> The following error messages can appear due to a failure occurring either while the power supply is operating or during selftest.		
SERIAL TIMOUT	Serial data line failure on A2 board.	See Figure 3-10 (system) or Figure 3-11 (bench).
SERIAL DOWN	Serial data line failure on A2 board.	See Figure 3-10 (system) or Figure 3-11 (bench).
UART PARITY	UART failed.	UART A2U112
UART FRAMING	UART failed.	UART A2U112
UART OVERRUN	UART failed.	UART A2U112
SBUF OVERRUN	Serial buffer failure UART.	UART A2U112 defective or HP-IB board is in SA mode
SBUF FULL	Serial buffer failure.	UART A2U112 defective or HP-IB board is in SA mode
EE WRITE ERR	EEPROM write failure.	EEPROM AIU6 defective or calibration error
SECONDARY DN	Serial data line failure on Main board.	See Figure 3-12.

## Troubleshooting Charts

Figure 3-1 gives overall troubleshooting procedures to isolate the fault to a circuit board or particular circuit (see Figure 3-20 for the location of the circuit boards). These procedures include the use of power-on selftest (Table 3-2) and signature analysis techniques (Table 3-5 through Table 3-7). Some results of Figure 3-1 lead to more detailed troubleshooting charts that guide you to specific components. The troubleshooting charts are organized as follows:

<b>Chart</b>	<b>Trouble or Circuit</b>
Figure 3-1	Overall procedure checks selftest errors, calibration errors, ac input circuit, fan, readback circuits, A10 Control Board, HP-IB cable, digital port, serial link, rotary controls, current amplifier.
Figure 3-2	No display (from Figure 3-1).
Figure 3-3	OV circuit not firing (from Figure 3-1).
Figure 3-4	OV circuit is on at turnon (from Figure 3-1).
Figure 3-5	Output level is held low (from Figure 3-1).
Figure 3-6	Output level is held high (from Figure 3-1).
Figure 3-7	DAC circuits (from Figure 3-1).
Figure 3-8	DAC test waveforms.
Figure 3-9	CV and CC DAC and amplifiers (from Figure 3-1).
Figure 3-10	Serial Down circuit (from Figure 3-1).
Figure 3-11	Secondary interface circuit (from Figure 3-1).
Figure 3-12	Slow downprogramming circuit (from Figure 3-1).

## Troubleshooting Test Points

The troubleshooting charts reference test points listed in Table 6-3 of Chapter 6. Test points are identified by an encircled number (such as ⑤ in schematic diagrams and component location drawings, also in Chapter 6).

## Bias and Reference Supplies

Many of the following troubleshooting procedures begin by checking the bias and/or reference voltages. Table 6-3 lists the test points for these voltages and gives the correct reading for each. The circuit board component location diagrams identify these points on each board.

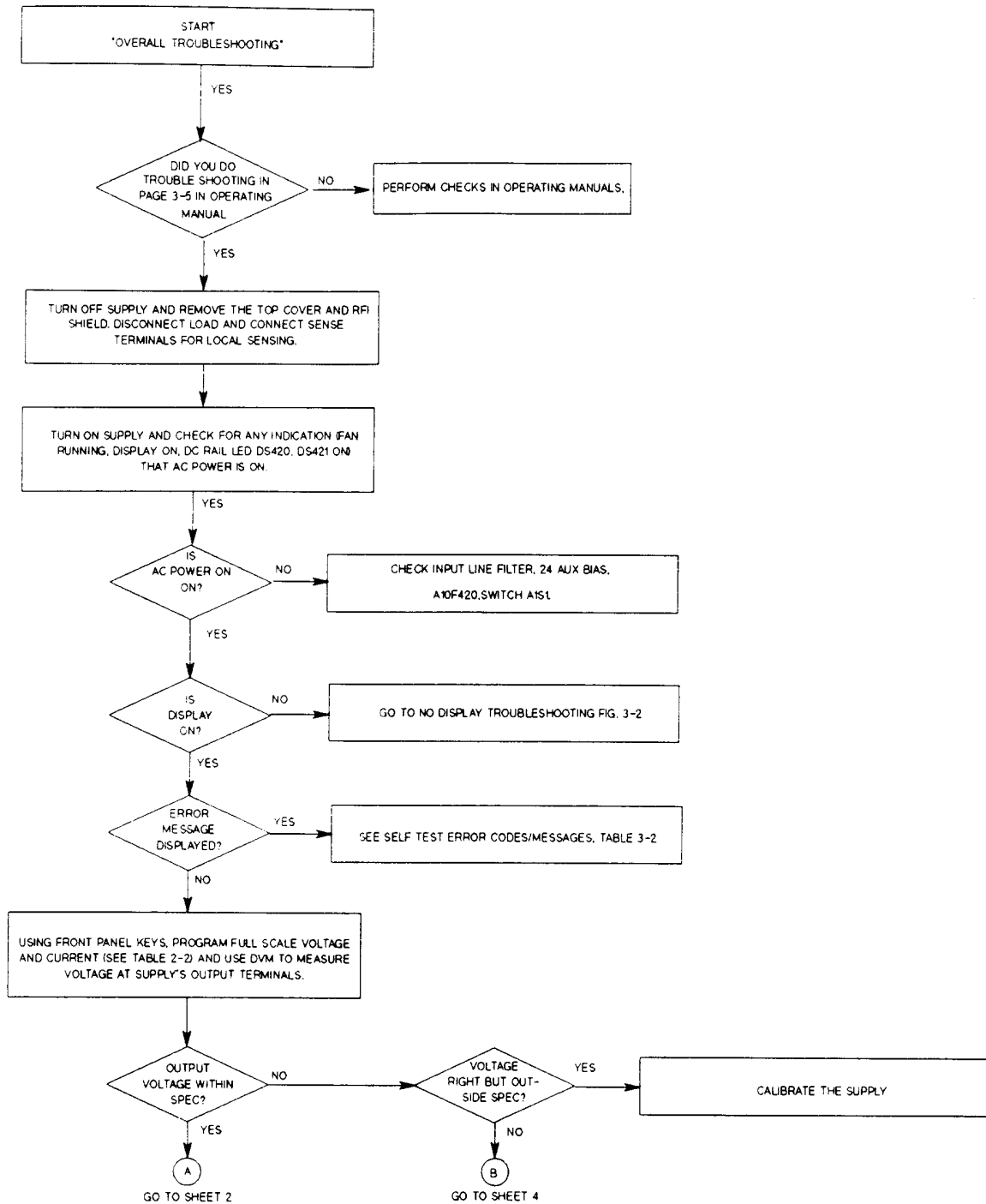

Figure 3-1. Overall Troubleshooting (Sheet 1 of 4)

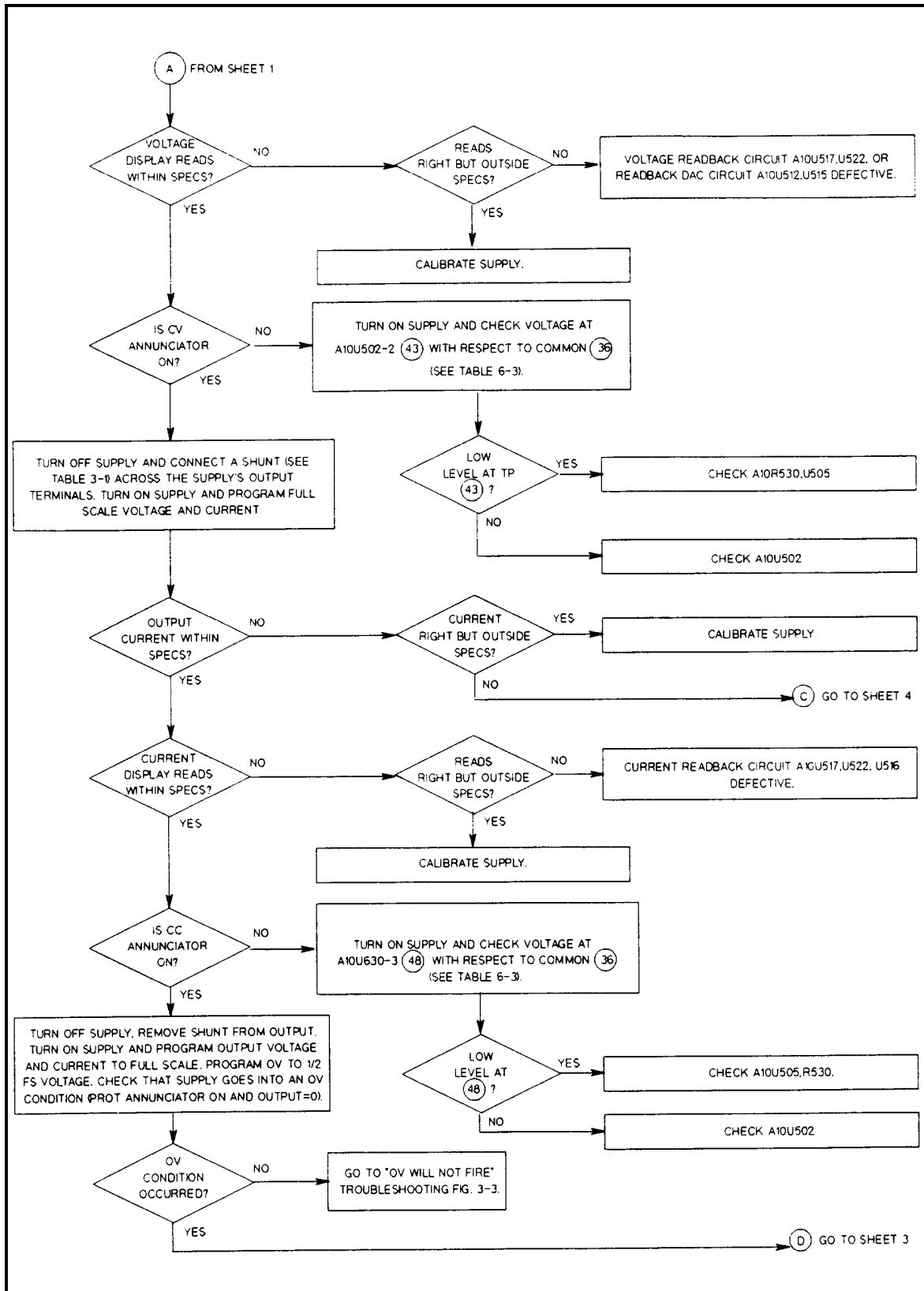

Figure 3-1. Overall Troubleshooting (Sheet 2 of 4)

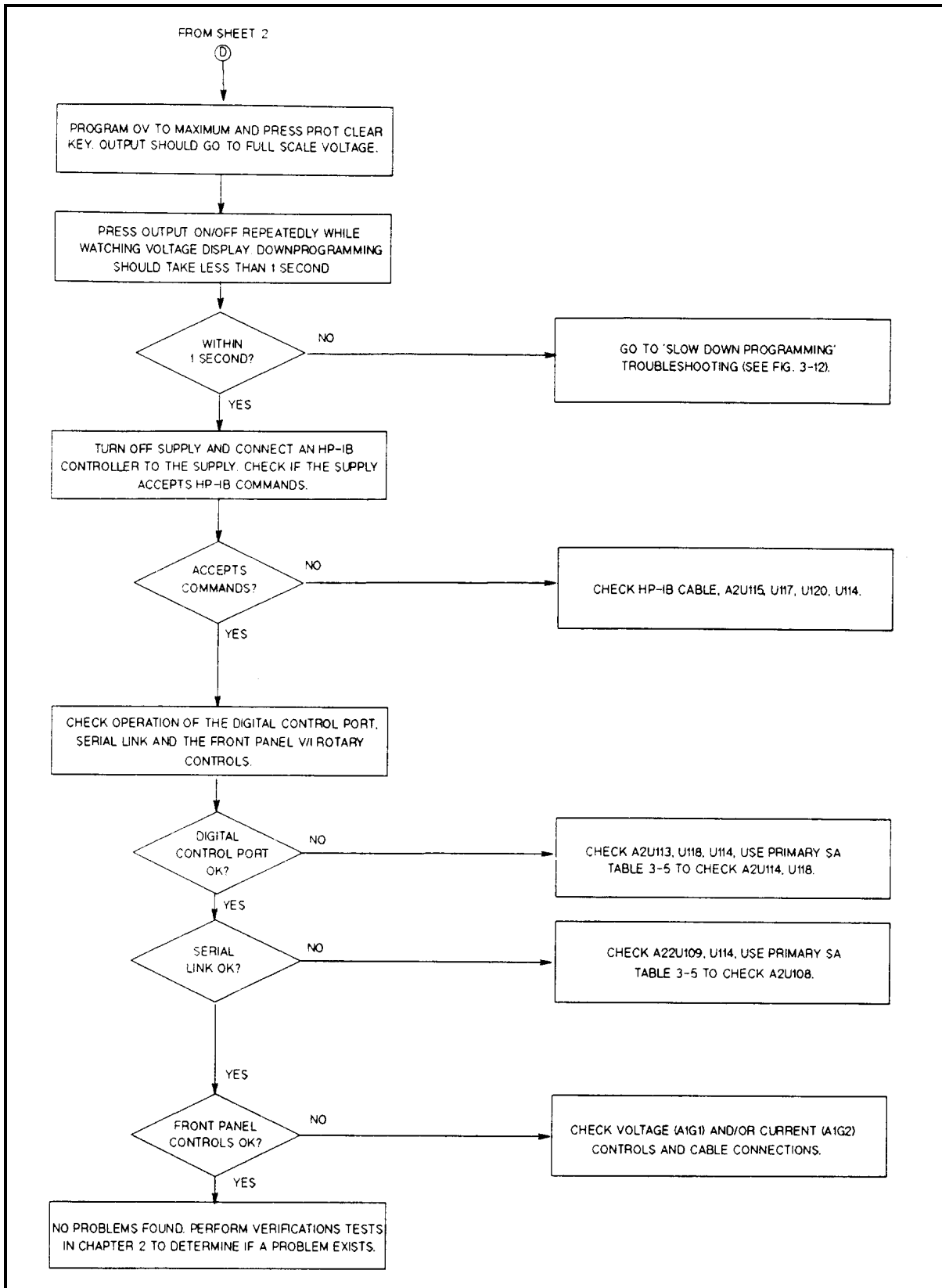

Figure 3-1. Overall Troubleshooting (Sheet 3 of 4)

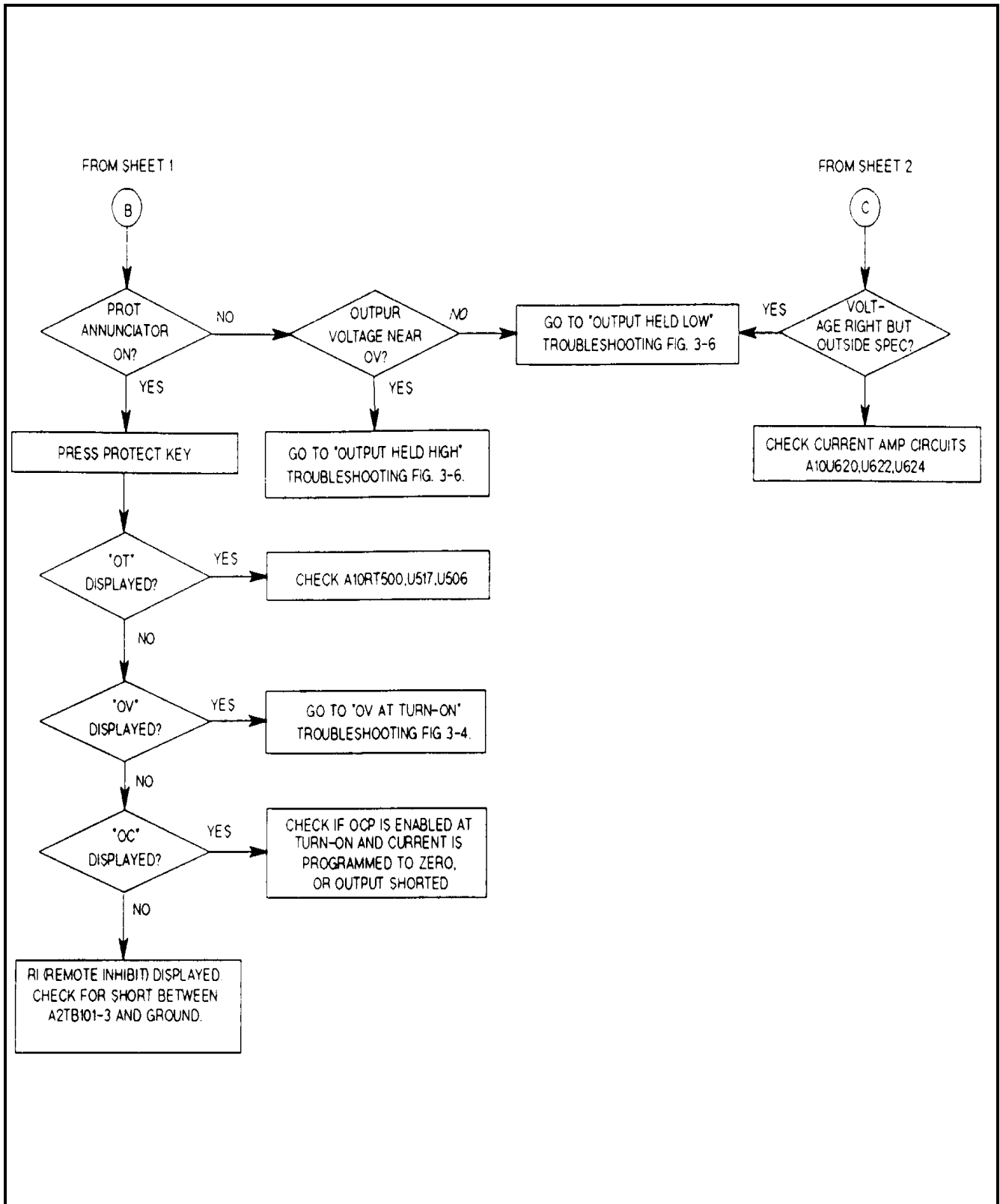
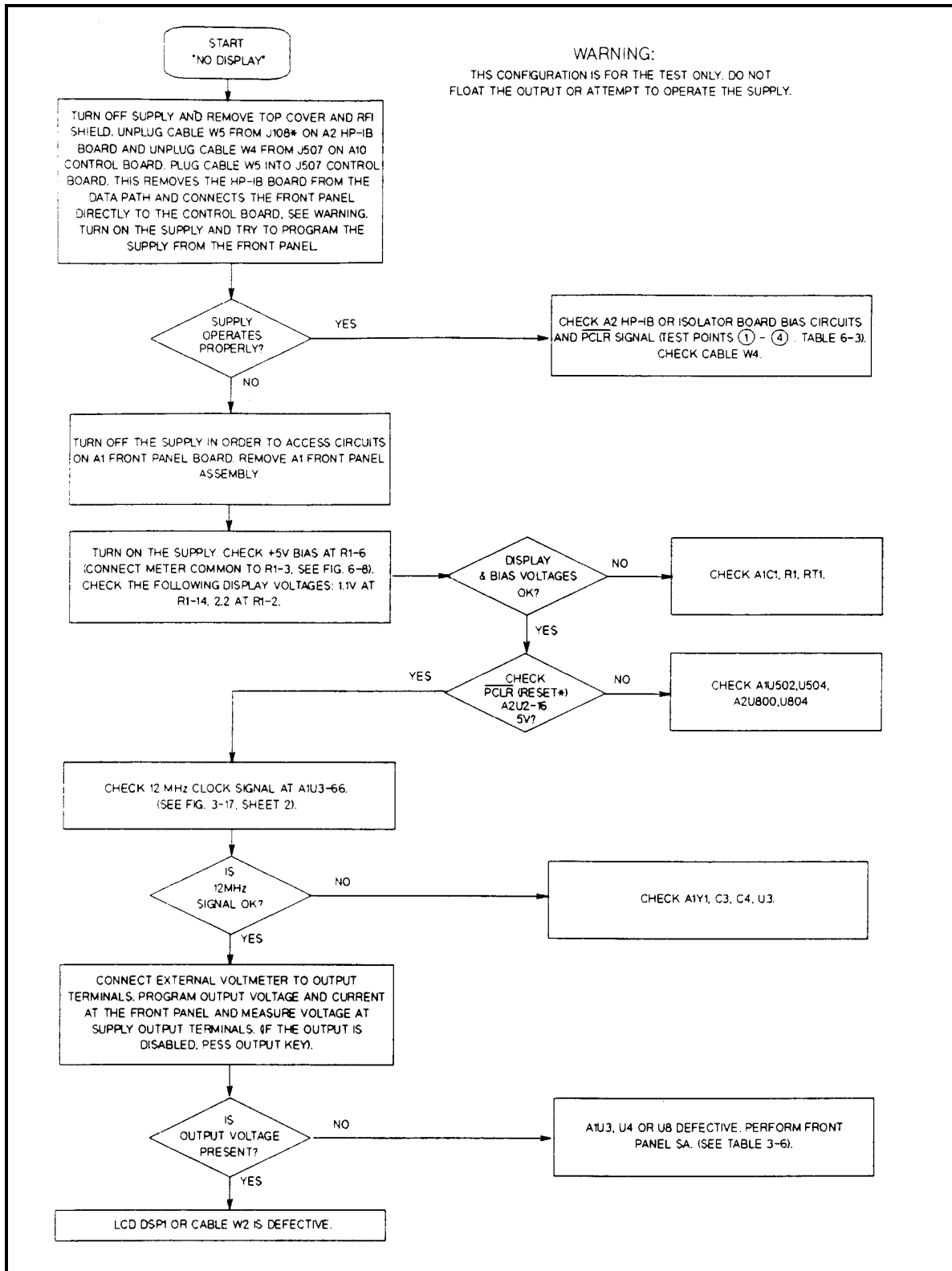

Figure 3-1. Overall Troubleshooting (Sheet 4 of 4)





**Figure 3-2. No Display Troubleshooting**

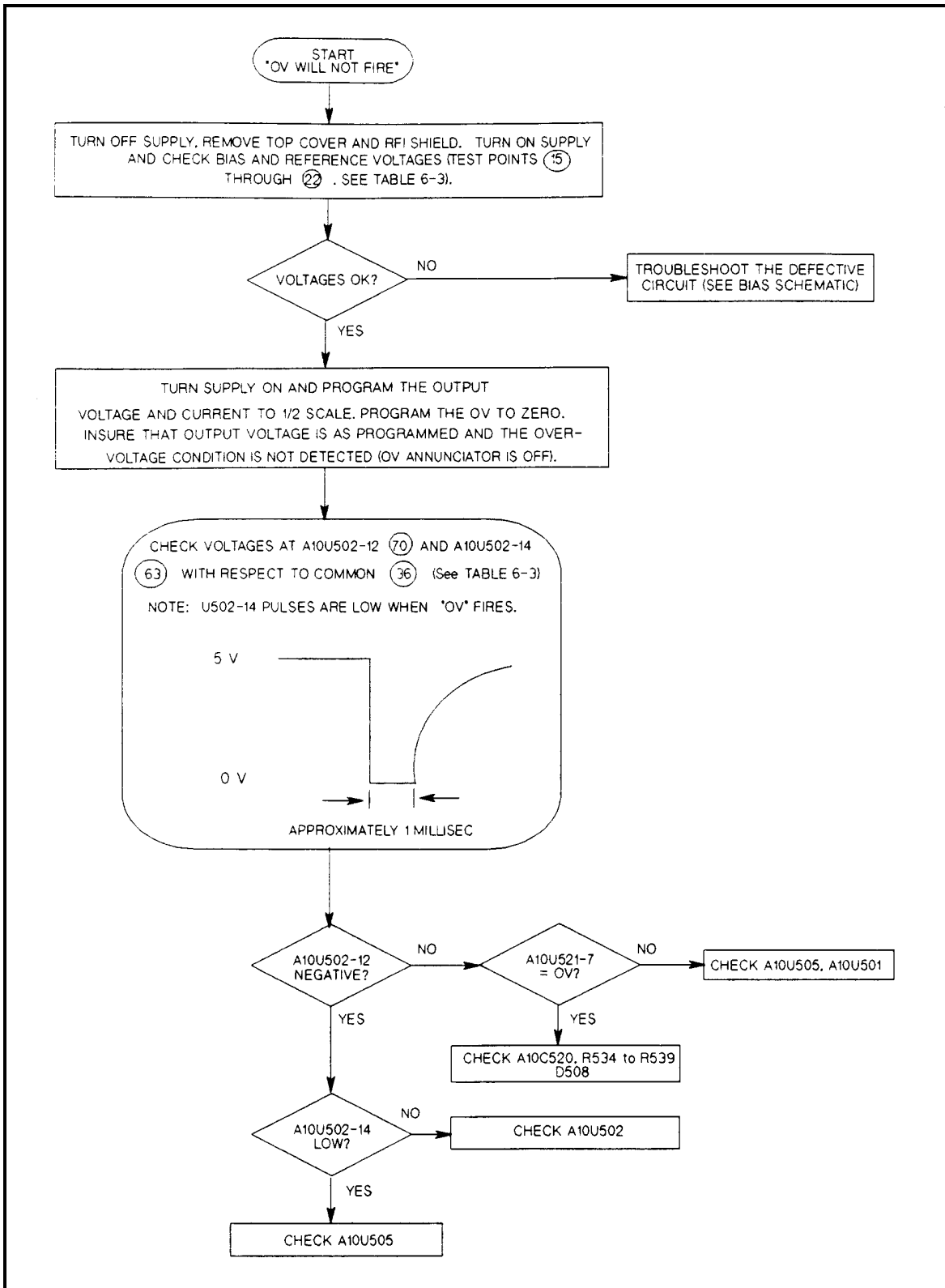

Figure 3-3. OV Will Not Fire Troubleshooting

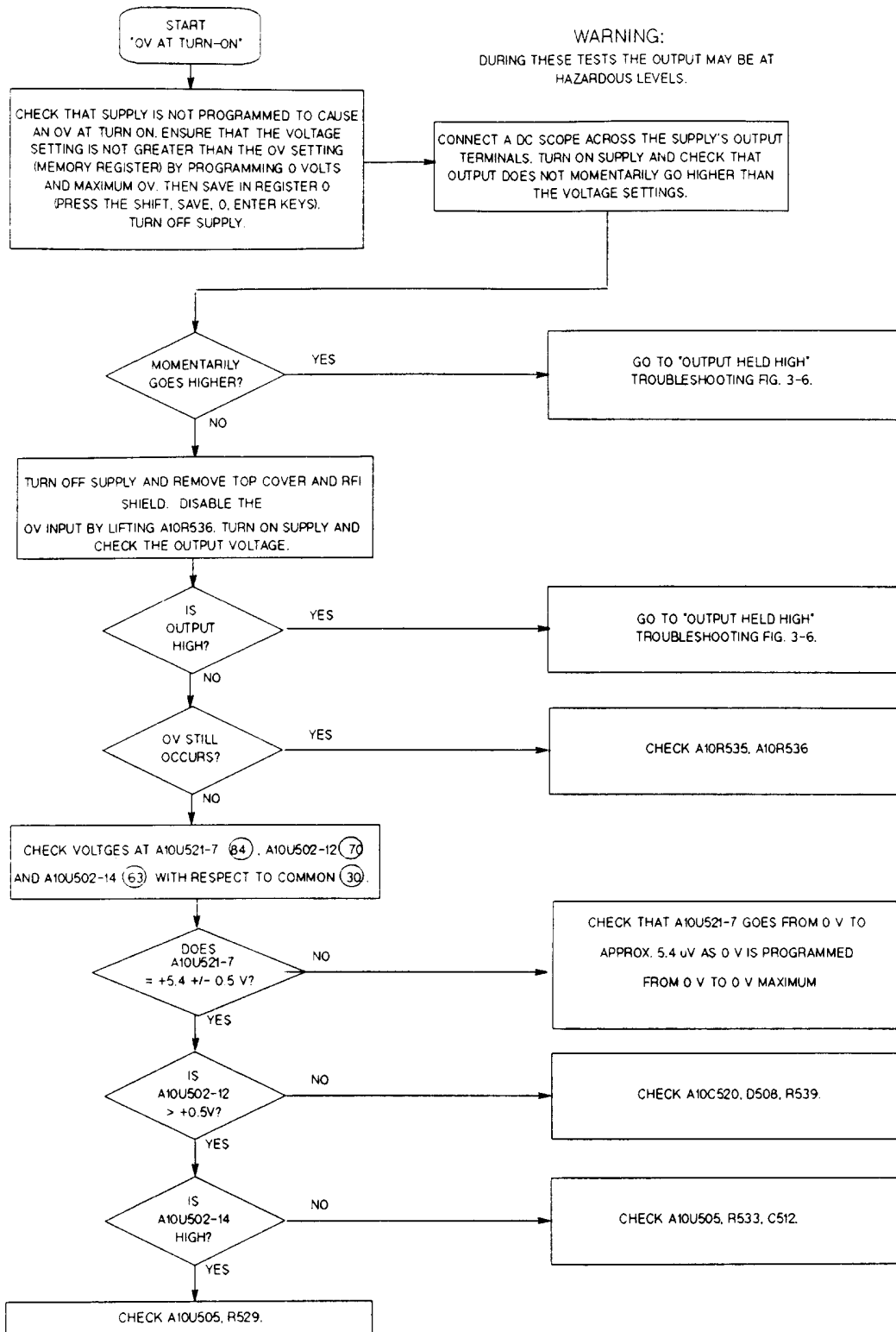

Figure 3-4. OV At Turn-On Troubleshooting

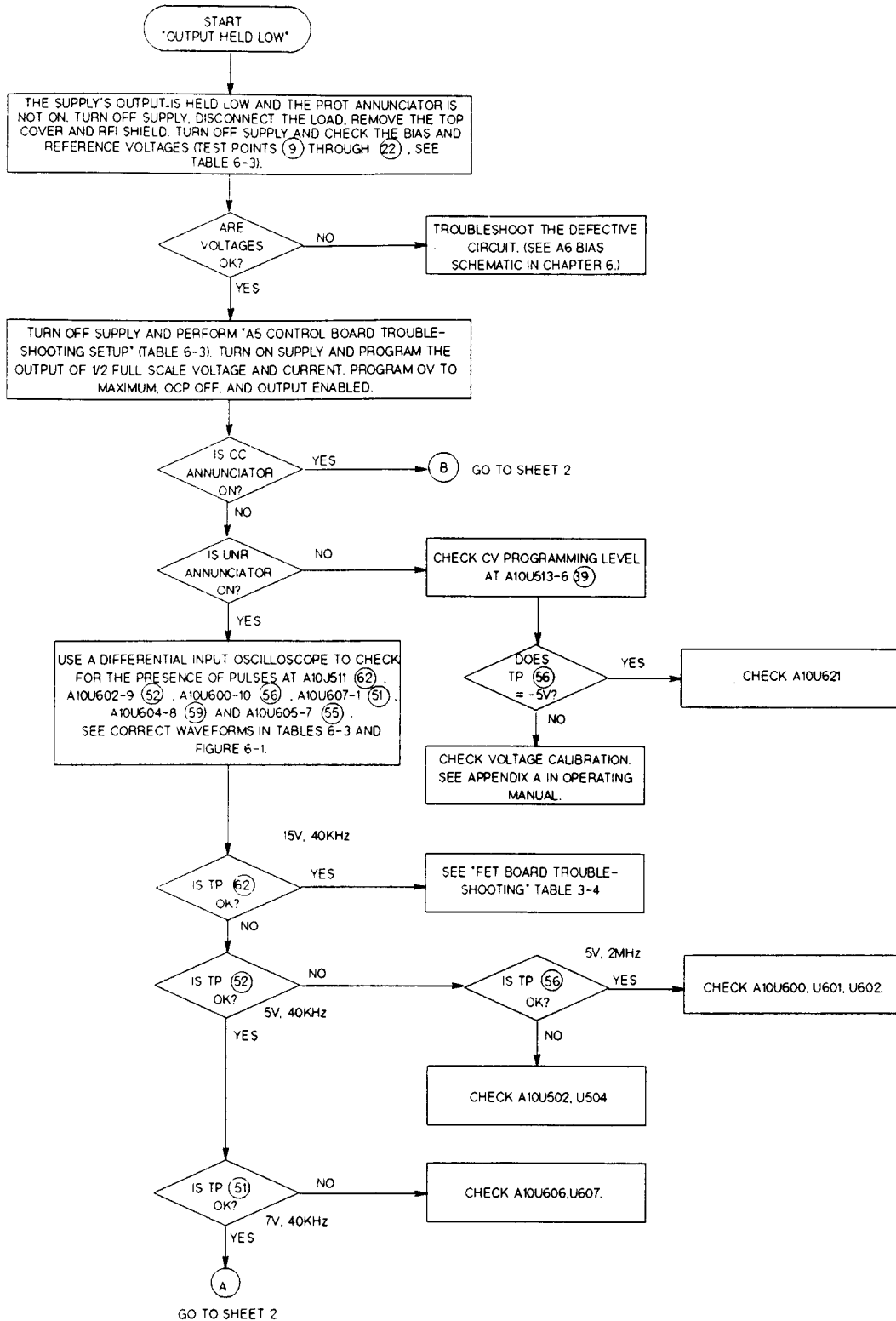

Figure 3-5. Output Held Low Troubleshooting (Sheet 1 of 2)

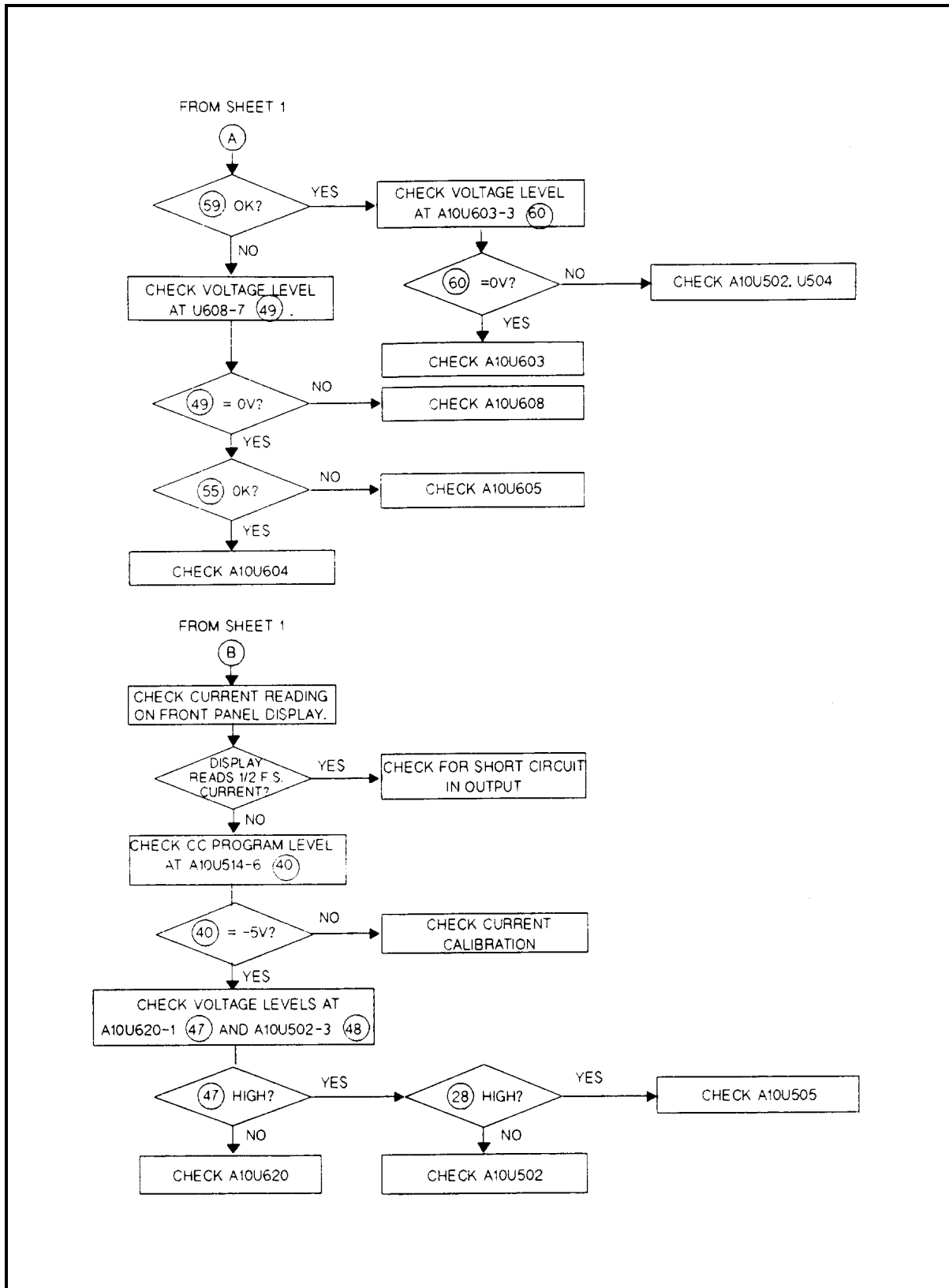

Figure 3-5. Output Held Low Troubleshooting (Sheet 2 of 2)

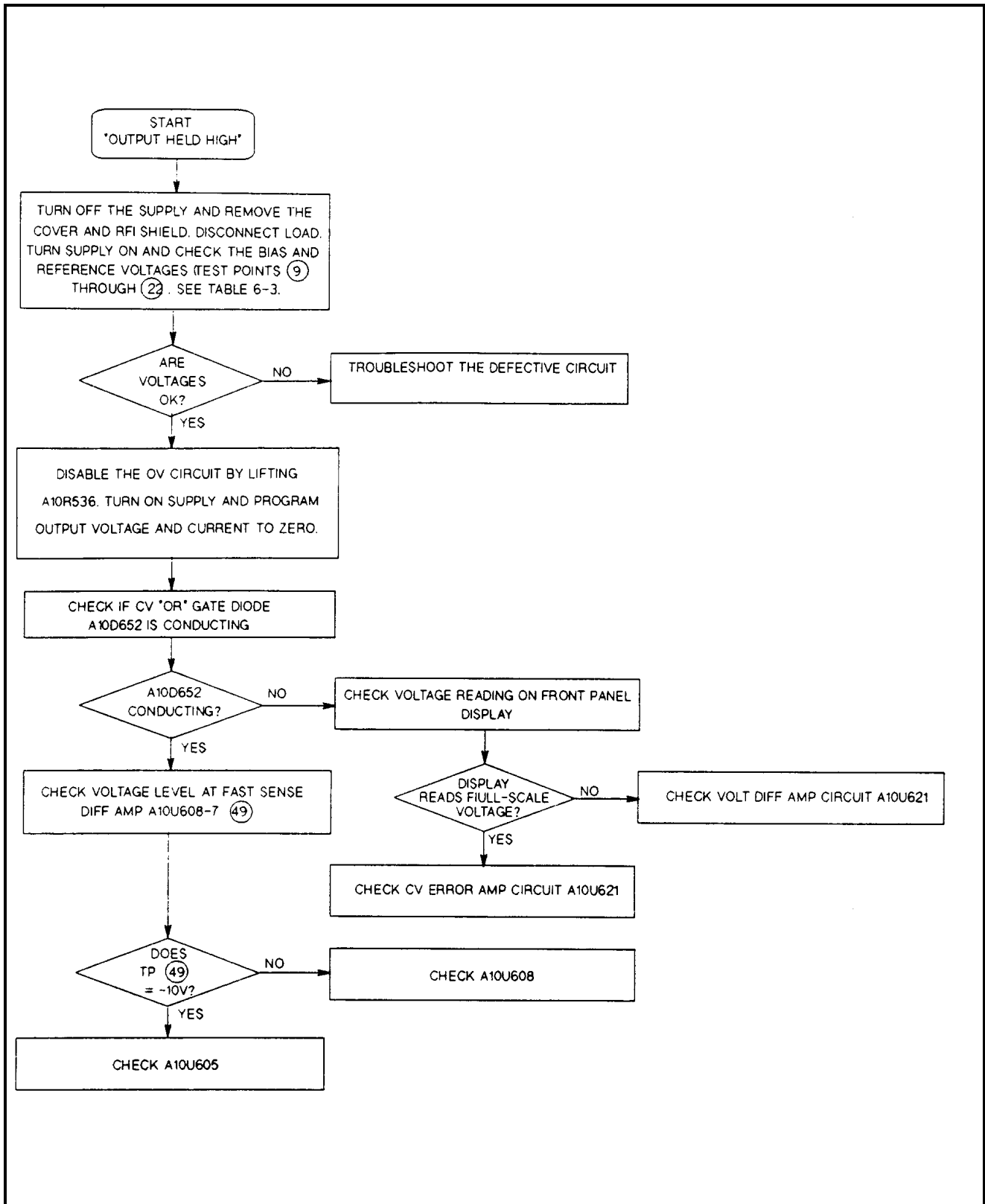

Figure 3-6. Output Held High Troubleshooting

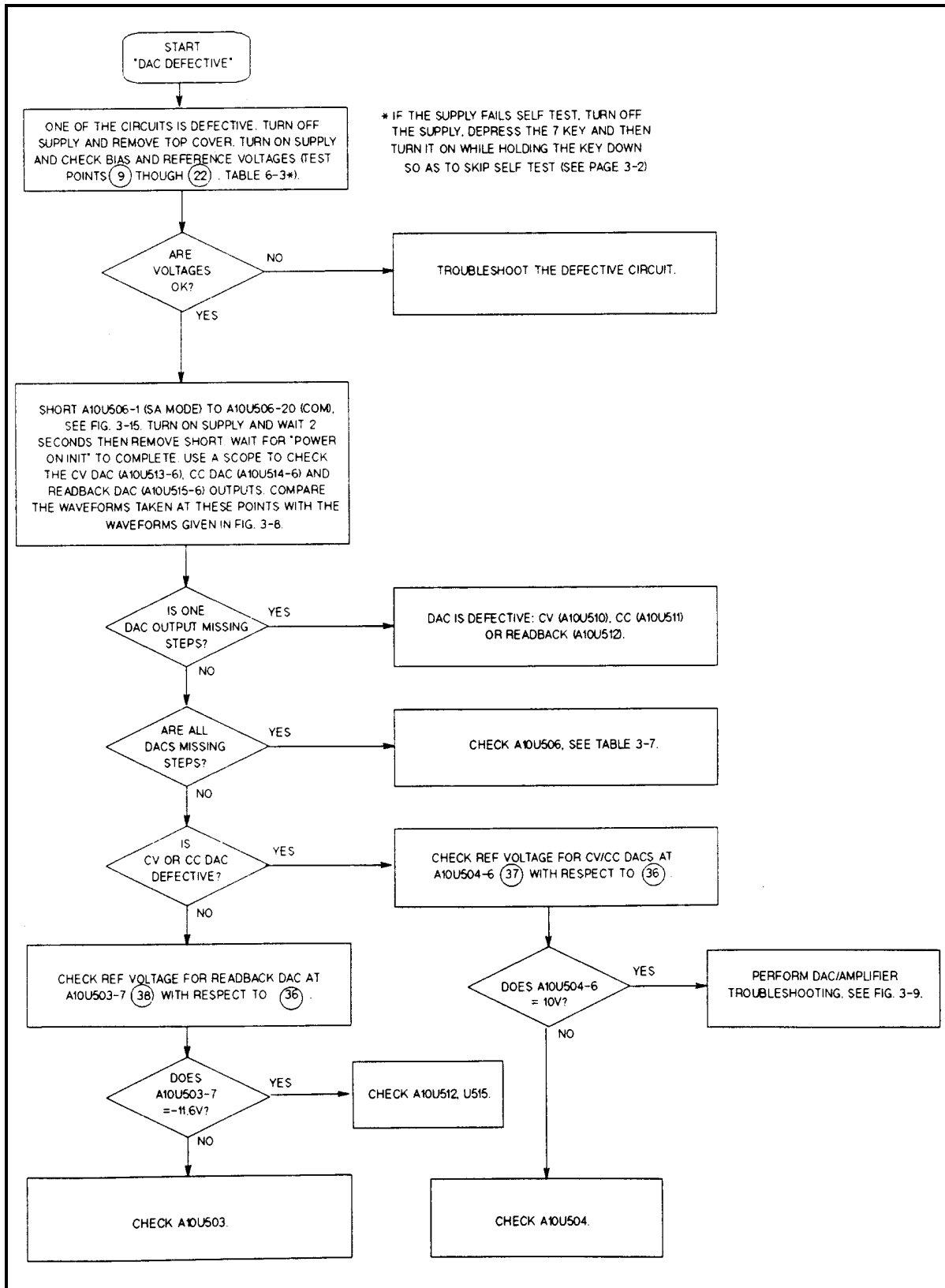
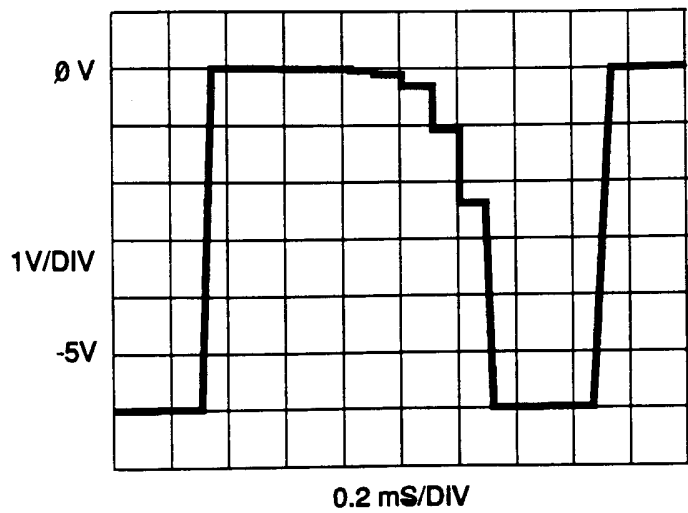
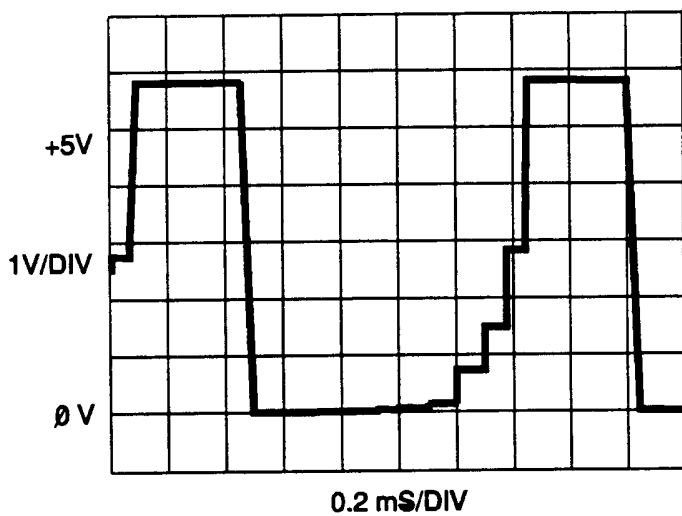

Figure 3-7. DAC Circuits Troubleshooting



A. CV DAC (U508-6) AND  
CC DAC (U510-6) OUTPUTS



B. READBACK DAC (U512-6) OUTPUT

Figure 3-8. DAC Test Waveforms



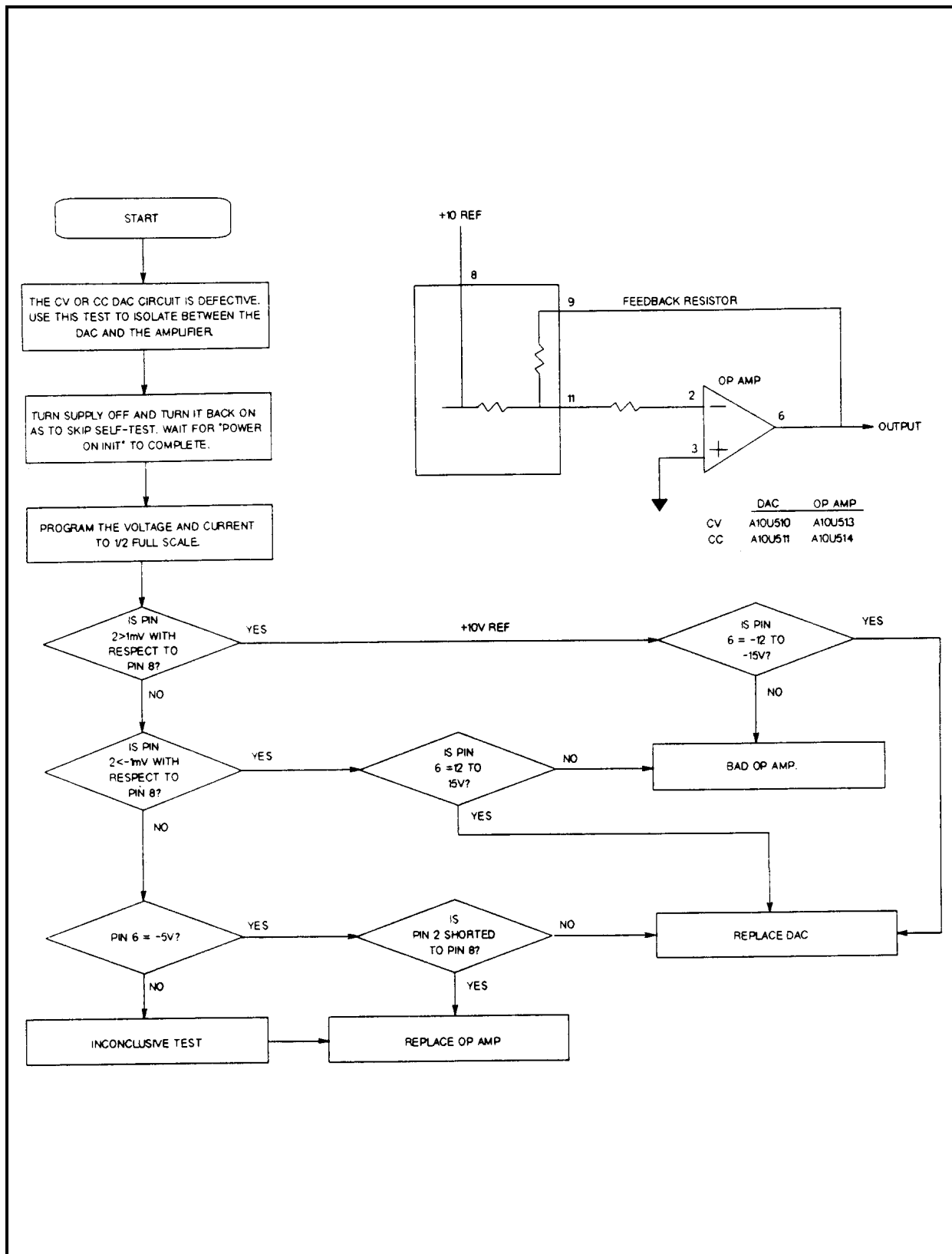

Figure 3-9. CV/CC DAC and Amplifier Circuit Troubleshooting

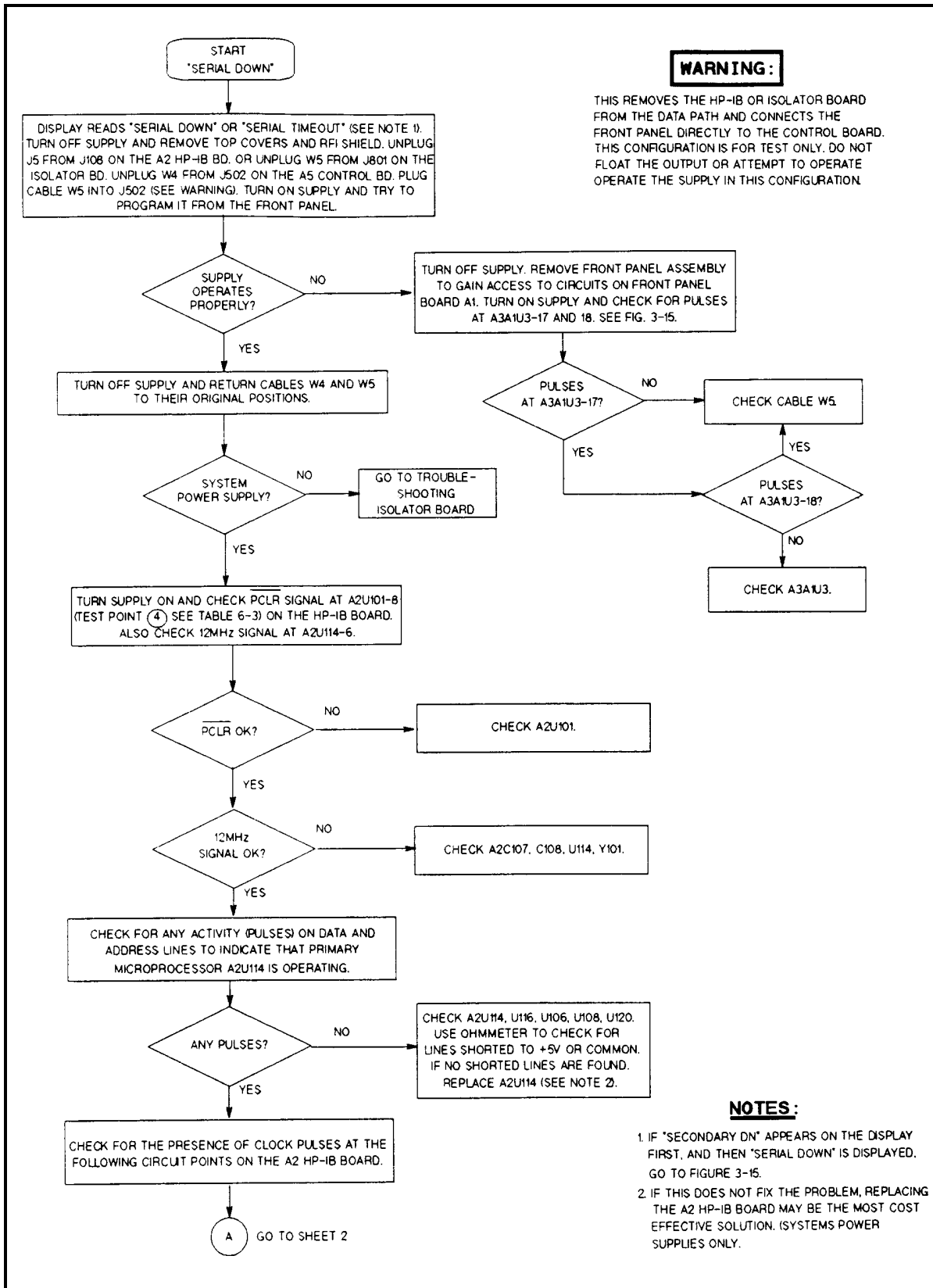

Figure 3-10. Serial Down Troubleshooting (Sheet 1 of 2)

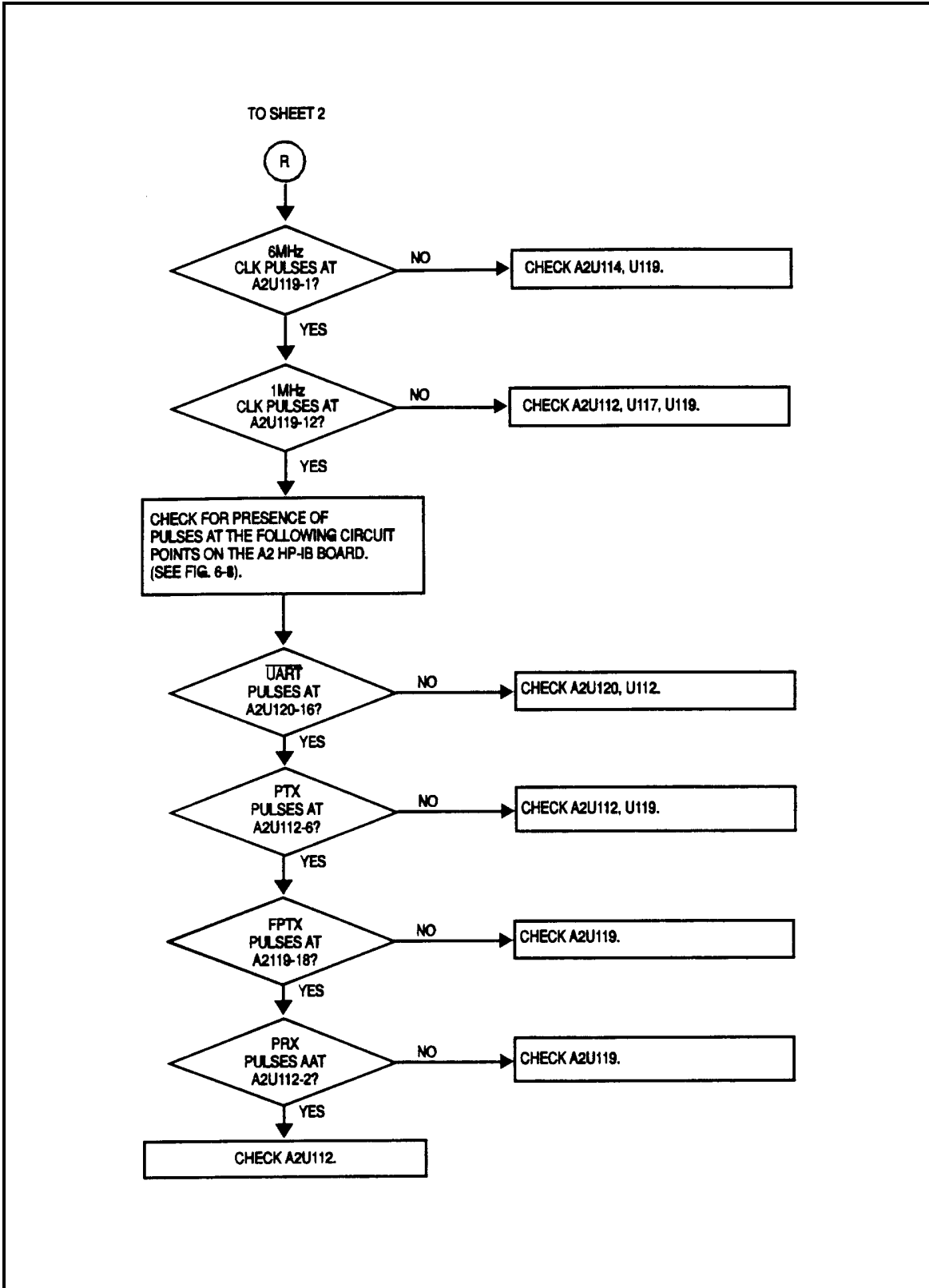

Figure 3-10. Serial Down Troubleshooting (Sheet 2 of 2)

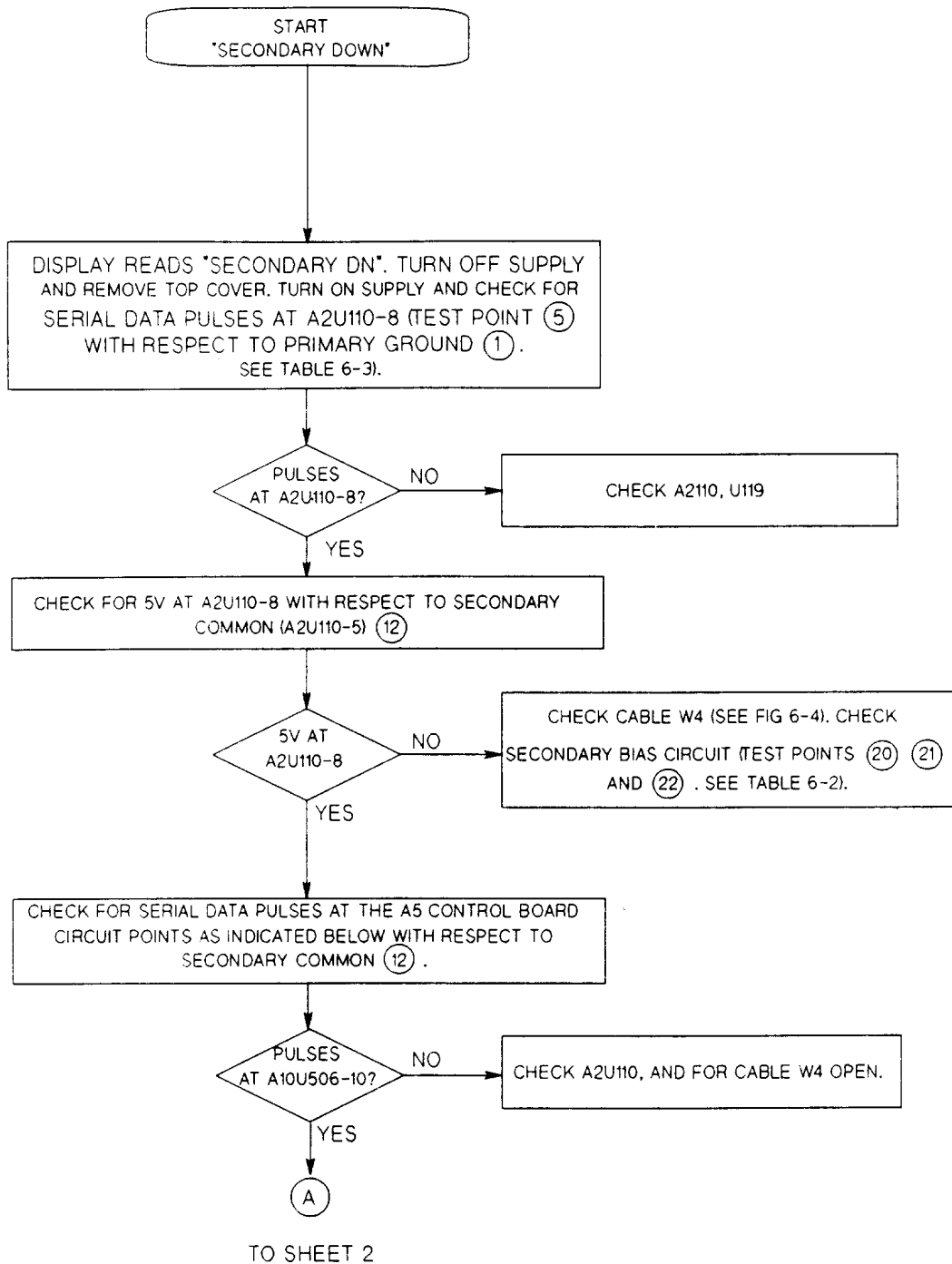

Figure 3-11. Secondary Interface Down (Sheet 1 of 2)

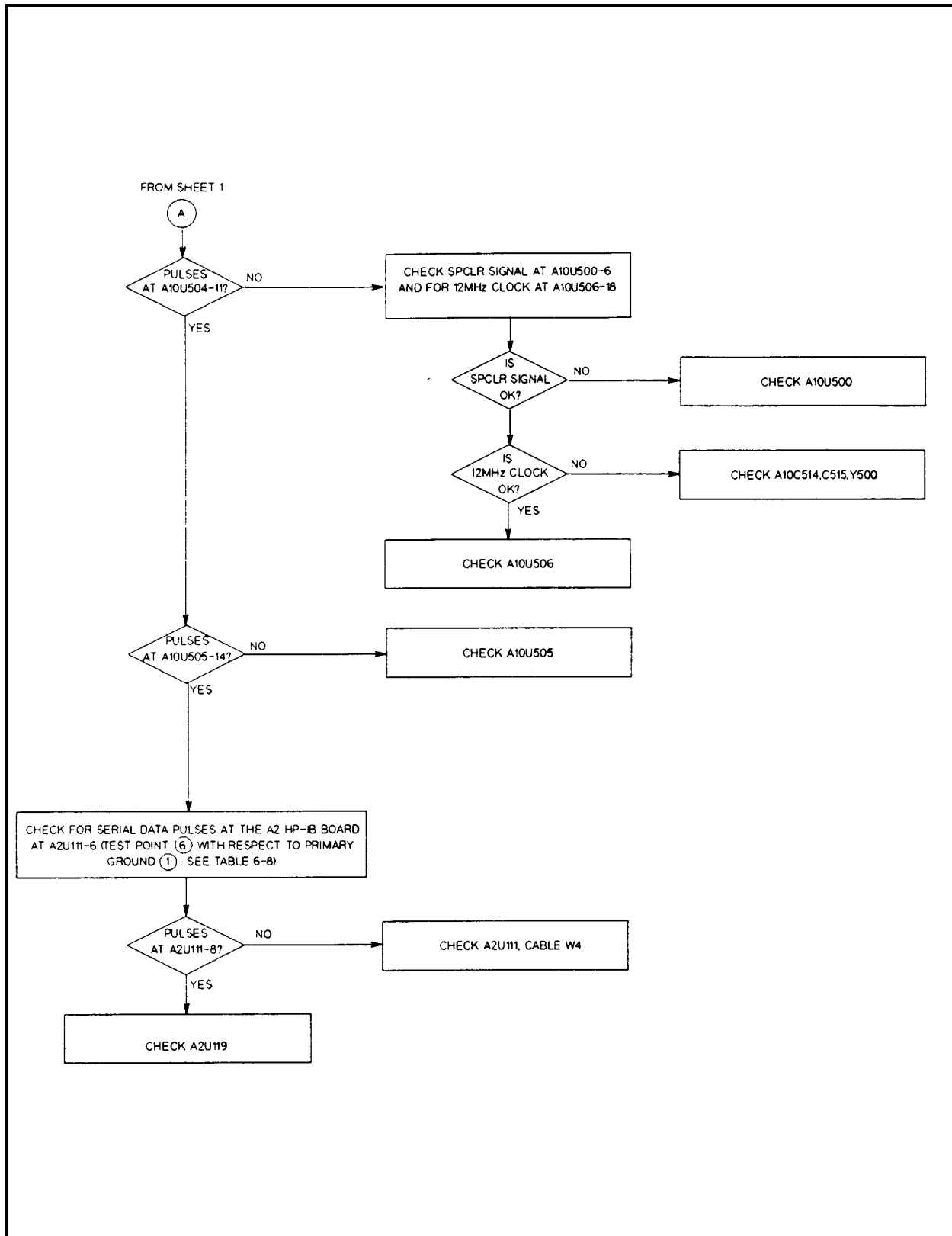

Figure 3-11. Secondary Interface Down (Sheet 2 of 2)

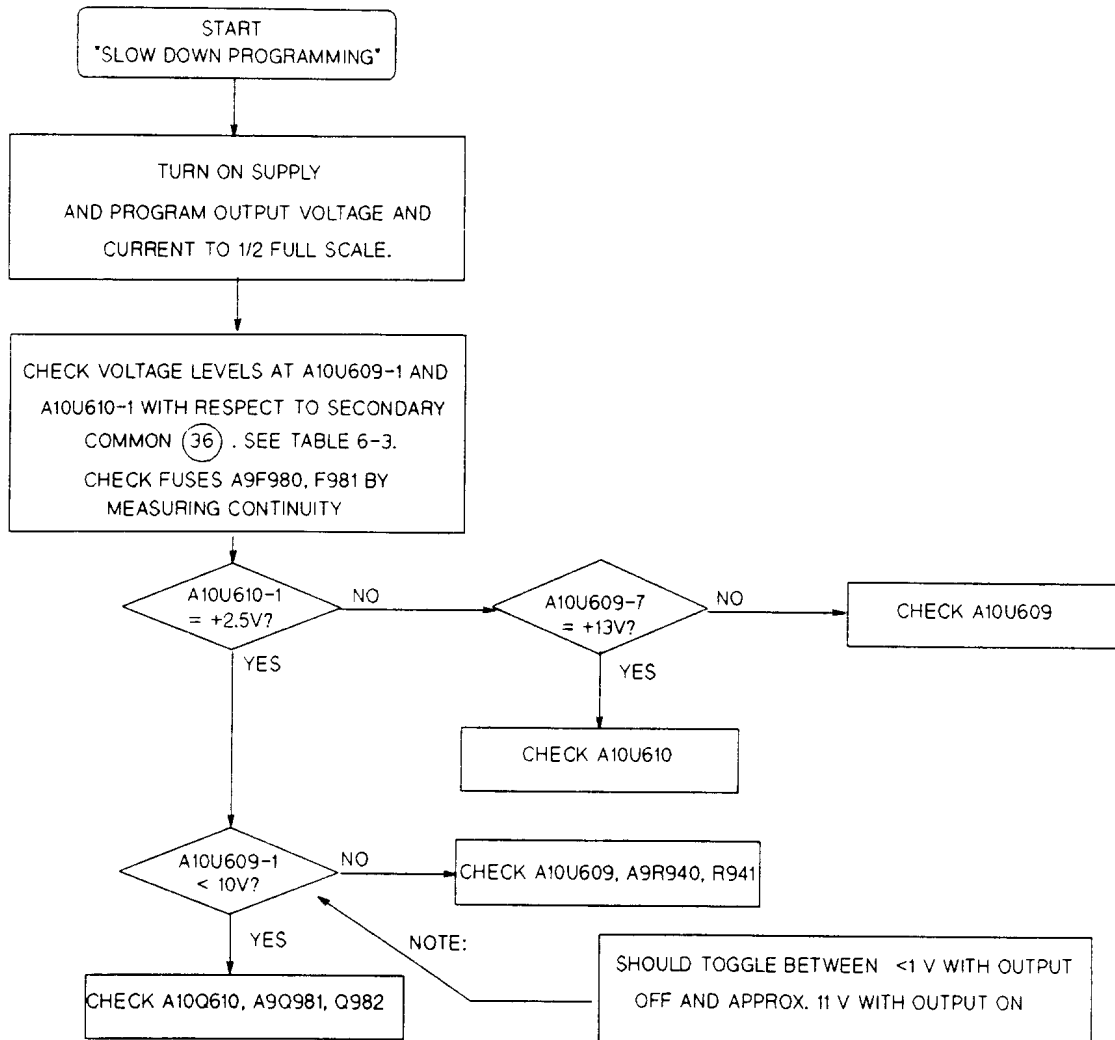

Figure 3-12. Slow Downprogramming Troubleshooting

## CV/CC Status Annunciators Troubleshooting

When troubleshooting the CV/CC status annunciators or status readback circuits, first measure the voltage drop across the gating diodes, which are A10D651 for the CC circuit and A10D652 for the CV circuit (see A10, Sheet 2). A conducting diode indicates an active (ON) control circuit. This forward drop is applied to the input of the associated status comparator (A10U502) and drives the output low. The low signal indicates an active status which is sent to the secondary microprocessor A10U506 via Programmed GAL A10U505 (see schematic Sheet 1). The front panel CV annunciator lights when the CV mode is active (CV is low) and the CC annunciator lights when the CC mode is active (CC is low). If neither is active, the UNREGULATED (Unr) annunciator comes on.

## A3 FET Board Troubleshooting

Because test points on the FET board are not accessible when the board is installed, troubleshooting must be performed with the board removed from the power supply. Both static (power removed) and dynamic (power applied) troubleshooting procedures are provided. The location of different test points are shown by encircled numbers on the A3 FET Board schematic and component location diagrams (see Chapter 6). There are two isolated FET bridge assemblies (see schematic in Fig. 6-10 sheets 1 and 2). Test each FET bridge individually.

---

**Note** If any power FET (Q201-204, Q301-304, Q211, Q311, Q222, Q322, Q233, Q333, Q244, Q344) is defective, you must replace all eight with a matched set.

---

**Table 3-4. FET Troubleshooting Chart**

Procedure	Result
<b>Static Troubleshooting</b>	
1. Turn the power supply off and remove the A3 FET board with its heatsink assembly attached (see "Disassembly Procedures").	
2. Measure the resistance between the + Rail (E202 & E302) and the - Rail ( E201 & E301).	$\geq 20M\Omega$ .
3. Measure the resistance between the gate of each FET (Q201-204, Q211, Q222, Q233, Q244, and Q301-304, Q311, Q322, Q333, and Q344) and common (-Rail).	$>15K\Omega$ .
4. Measure the resistance across capacitor C201 & C301.	$\approx 150\Omega$ .
5. Measure the resistance across the 15V bias input (E206 to E207 and E306 to E307).	$\approx 1K\Omega$ in the forward direction and $490\Omega$ in the reverse direction.
<i>Continue with Dynamic Troubleshooting on the next page</i>	

**Table 3-4. FET Troubleshooting Chart (continued)**

Procedure	Result
<b>Dynamic Troubleshooting</b>	
1. Turn off the power supply and remove the A3 FET Board with its heat sink assembly.	See "Disassembly Procedures"
2. Short the collectors of Q251 and Q253 or Q351 and Q353 by connecting the collector (case) of each transistor to common ( E507) .	
3. Connect waveform generator to J200-1 and J200-2.	
4. Set generator to produce a 20 kHz, 20V p-p triangular waveform	See Figure 3-14A.
5. Connect 15V from an external supply to E206 or E306 (positive) and E207 or E307 (common).  Note: All of the following measurements are taken with respect to E207/E307 common, test point (26) on A3 FET Board schematic diagram	
6. Check bias voltage at U203-1/U303-1 (27) .	+5V
7. While adjusting the external 15V supply input, check the bias trip point at U204-1/U304-1 (28) .	Voltage goes from low (0V) to high (5V) at an input of approximately 12V; and from high to low at an input of approximately 13V.
8. Set external supply input to + 15V and check drive 1 waveform at U201-10/U301-10 (29) and drive 2 waveform at U201-12/U301-12 (30) .	See Figure 3-14B.
9. Check that pulses are present at U201-1 (31) , U201-7/U301-7 (32) and U302-1, U202-1 (33) , U202-7/U302-7 (34) .	See Figure 3-14C.
10. Pulses should be present on both sides of inductors L201-204 or L301-304 and L213-216 or L313-316 as follows:  Check the pulses on the driver transistor side (Q251-Q254/Q351-Q354) of each inductor.  Check the pulses on the FET regulator side (Q201-Q204, Q301-Q304, Q211, Q311, Q222, Q322, Q233, Q333 and Q244, Q344) of each inductor.  If the waveforms do not have the fast step as shown in Figure 3-14, then the associated FET gate input has an open circuit.	See Figure 3-14D.  See Figure 3-14E.
11. Measure the VREF voltage at U205-2 (35) .	≈ 1.7V
Check the peak current limit by connecting a 68KΩ resistor from +5V (U201-9) to U205-3 or U304-5.	All pulses turn off.



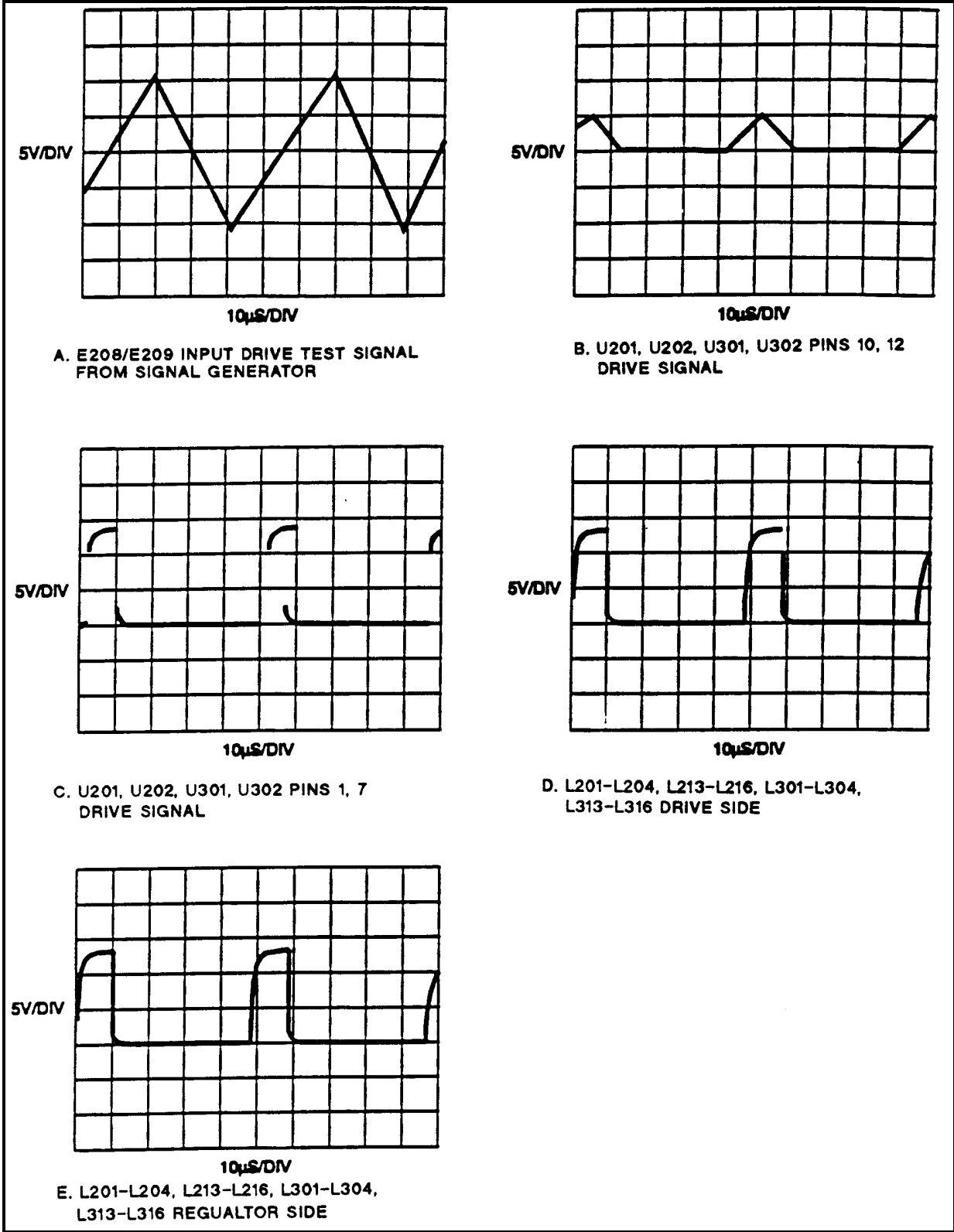

Figure 3-13. A3 FET Board Test Waveforms

---

## Signature Analysis

### Introduction

The easiest and most efficient method of troubleshooting microprocessor-based instruments is with signature analysis (SA). This technique is similar to signal tracing with an oscilloscope in linear circuits. Part of the microprocessor memory is dedicated to SA, and a known bit stream is generated to stimulate as many nodes as possible within a circuit. Because it is virtually impossible to analyze a bit stream with an oscilloscope, a signature analyzer is used to compress the bit stream into a four-character signature. By comparing the signatures of the IC under test to the correct signature for each node, you can isolate faults to one or two components .

The following general rules apply to signature analysis testing:

1. Be sure to use the correct test setup connections for the specific test.
2. When examining an IC, note the correct signatures for Vcc (+5V) and for common. If an incorrect signature matches either one, it probably indicates a short to that part of the circuit.
3. If two IC pins have identical signatures, they are probably shorted.
4. If two IC signatures are similar, it is only a coincidence.
5. If an input pin of an IC has an incorrect signal but the signal source (output of the previous IC) is correct, then look for an open printed circuit track or soldering problems.
6. If the output signature of an IC is incorrect, it could be caused by that IC. However, it could also be caused by a short at another component that is connected to that output.

### Firmware Revisions

Each signature analysis table in this chapter shows the power supply firmware revision for which the table is valid. If needed, for a Bench Supply you can confirm the firmware revision of your power supply by checking the label on the Front panel ROM, AIU3, and on the Secondary microprocessor, A5U504. You can obtain the revisions on a Systems Supply with the HP-IB \*IDN? query command. The following sample HPBASIC program does this:

```
10 ALLOCATE L$(52)
20 OUTPUT 705;"*IDN?"
30 ENTER 705;L$
40 DISP L$
50 END
```

For a typical Model 6681A, the controller will return a string with four comma-separated fields, as follows:

```
"HEWLETT-PACKARD,6681A,O,fA.01.05sA.01.04pA.01.02"
```

The first three fields in the string are the manufacturer, model number and 0. The last field gives the firmware information as follows:

```
f= front panel firmware revision (A.01.05).
s= secondary interface firmware revision (A.01.04).
p= primary interface firmware revision (A.01.02).
```

---

#### Note

The firmware revisions numbers shown here may not match the firmware revision of your instrument. Firmware revision numbers are subject to change whenever the firmware is updated.

---

## Test Headers

The power supply has two test headers as shown in Figure 3-15, each with a jumper that can be moved to different positions for SA testing and for other functions. To gain access to the headers, remove the power supply top cover.



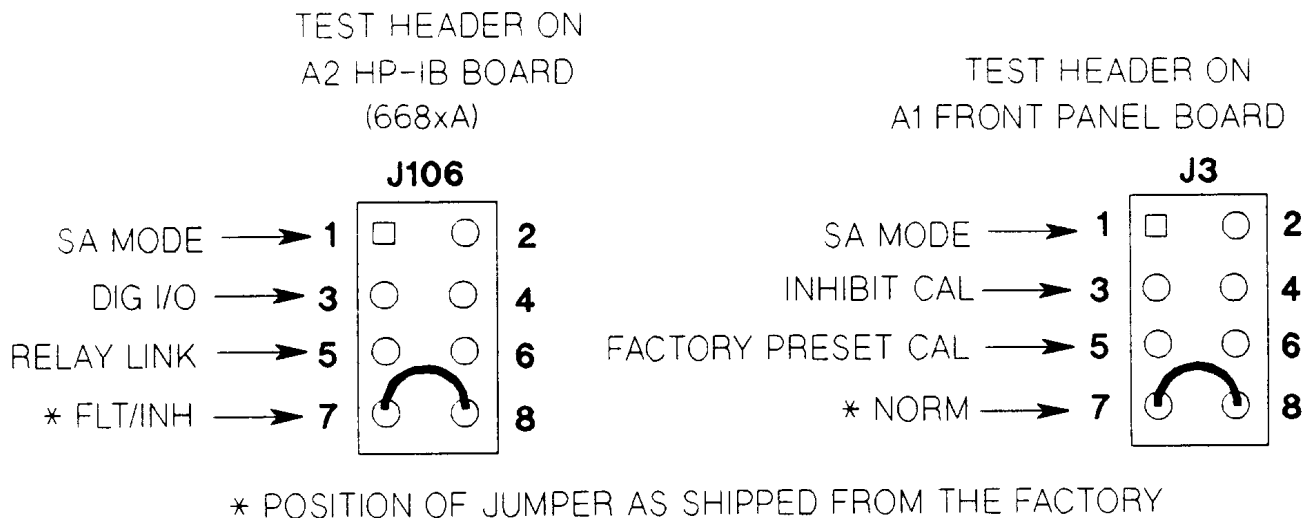

Pins	Description
<b>Primary Interface Test Connector A2J106 (Systems Supplies Only)</b>	
7 and 8 (FLT/INH)	Normal operating (and storage) position. DIG CNTL port** is configured for fault indicator (FLT) output and remote inhibit (RI) input .
1 and 2 (SA Mode)	Install jumper here for SA mode.
3 and 4 (DIG I/O)	Install jumper here to configure DIG CNTL port** for digital I/O operation .
5 and 6 (RELAY LINK)	Install jumper here to configure DIG CNTL port** for control of external relay accessories. ** See Appendix D in power supply Operating Manual for information about the digital control port.
<b>Front Panel Test Connector A1J3</b>	
7 and 8 (NORM)	Normal operating (and storage) position of jumper.
1 and 2 (SA Mode)	Install jumper here for SA mode.
3 and 4 (INHIBIT CAL)	Install jumper here to disable calibration commands and prohibit calibration.
5 and 6 (FACTORY PRESET CAL)	Install jumper here to restore original factory calibration constants.



**Figure 3-14. Test Header Jumper Positions**

**Table 3-5. Primary Interface SA Test**

<p><b>Description:</b> These signatures check some primary interface circuits on the Systems Supply A2 HP-IB Board.  <b>Valid A2U106 ROM Firmware Revision:</b> A.01.06  <b>Test Setup:</b> See Figure 3-17.</p>
1. Turn off the power supply and remove the top cover.
2. Connect SA jumper of connector J106 on A2 HP-IB Board (see Figure 3-15).
3. Connect signature analyzer CLOCK, START, STOP, and GROUND inputs as show in Figure 3- 16 .
<p>4. Turn on the power supply and use the signature analyzer probe to take the following signatures:</p> <p>Power: 5V = 9FFP  Serial Link: A2U109-3 = 0104  Microprocessor: A2U114-24 = 9FFP  A2U114-25 = UF39  Digital Control Interface: A2U118-1 = 9AF1  A2U118-9 = 40A5  A2U118-10 = 1029  A2U118-15 = 0010  A2U118-16 = 040A  Gated Array Logic: A2U119-2 = 0A55  A2U119-5 = 0040  A2U119-15 = 0040</p>
5. After completing the tests, be sure to return the J106 jumper to its original position.

Signature Analyzer Input	Edge Setting	A2 Board Connection	A1A1 Front Panel Board Connection	A10 Board Connection
CLOCK		J106-5	J2-9	U504-32
START		J106-6	J2-11	U502-7
STOP		J106-6	J2-11	U502-7
GROUND		J106-4	J2-8	U502-10

**Figure 3-15. Signature Analysis Signal Inputs**

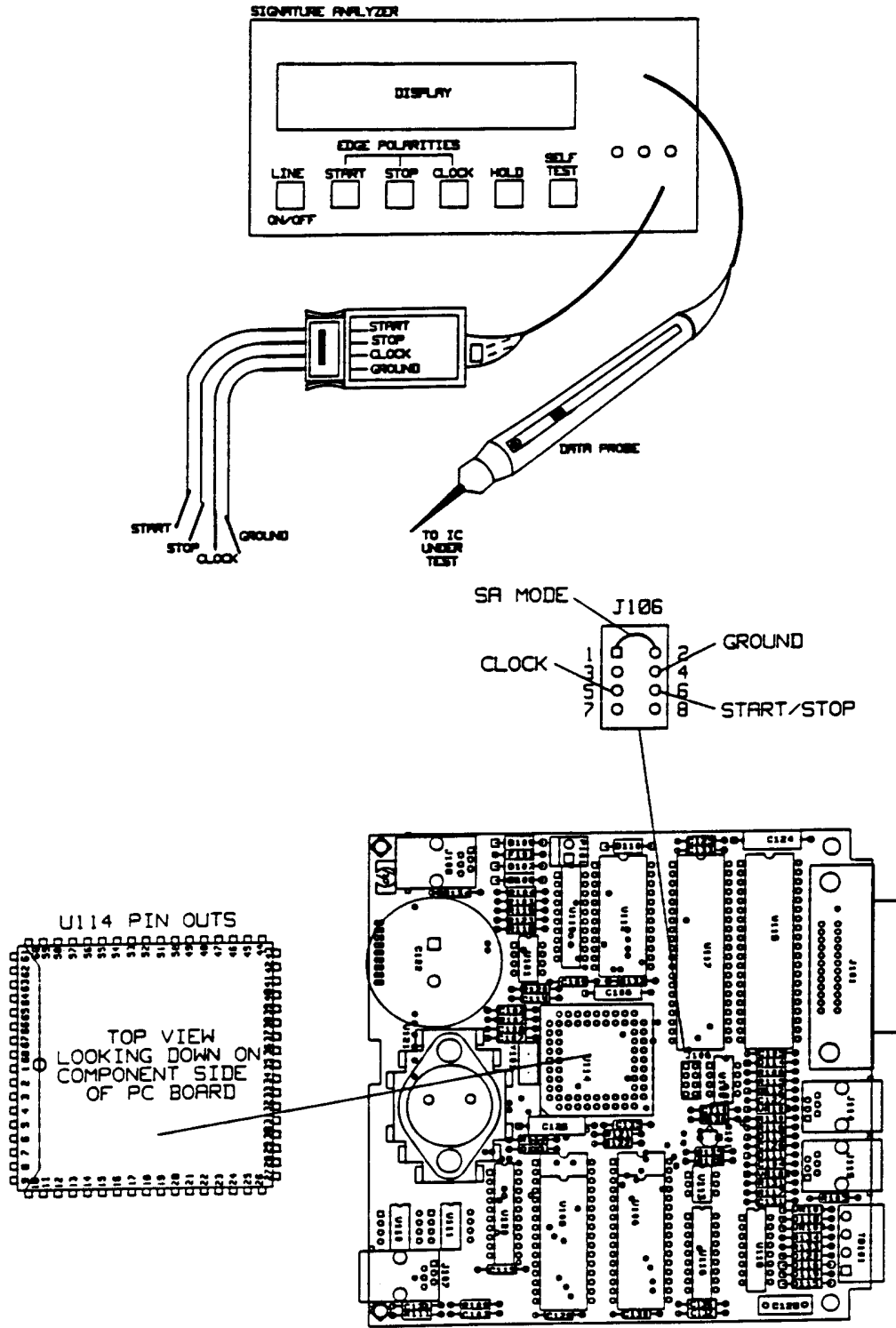

A. A2 HP-IB Board

Figure 3-16. Signature Analysis Connections, (Sheet 1 of 2)

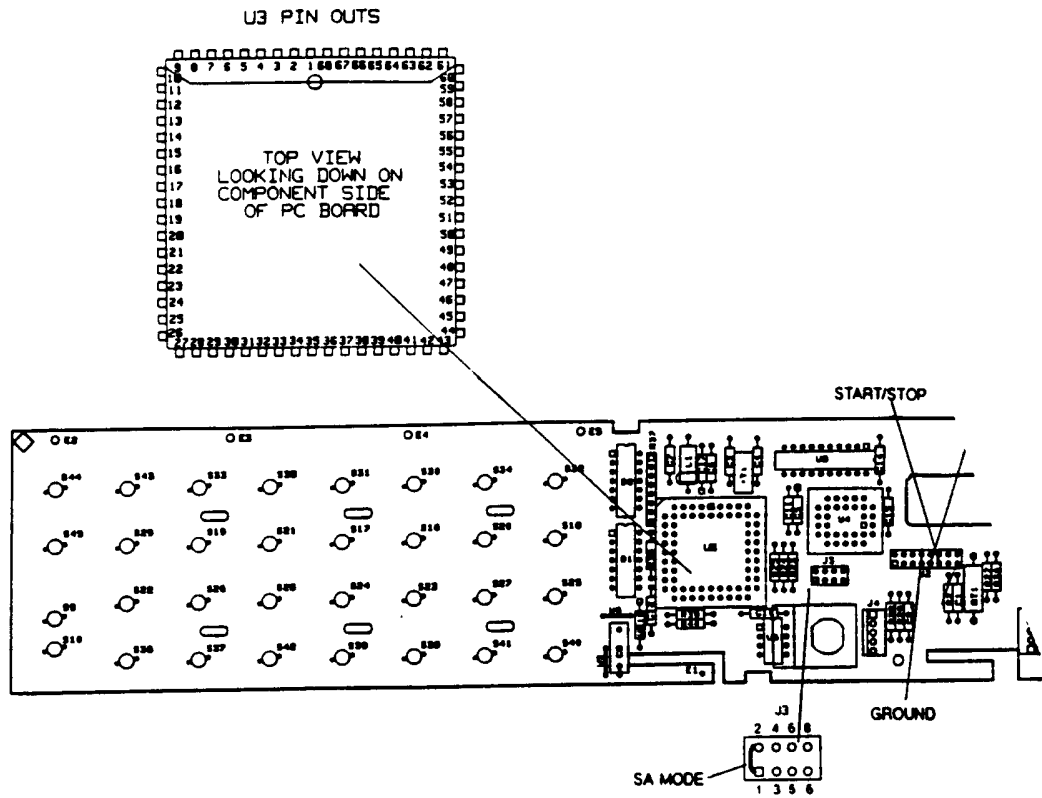

b. A3 FRONT PANEL BOARD (ALL MODELS)

Figure 3-16. Signature Analysis Connections, (Sheet 2 of 2)

**Table 3-6. Front Panel SA Test**

<p><b>Description:</b> These signatures check front panel microprocessor AIU3.  <b>Valid A1U4 ROM Firmware Revision:</b> A.01.07  <b>Test Setup:</b> See Figure 3-17.</p>																																					
1.	Turn off the power supply and remove the top cover.																																				
2.	To gain access to A1 Front Panel Board, perform steps 1 and 2 of the disassembly procedure for A1 Front Panel Assembly (see "Disassembly Procedures").																																				
3.	Connect SA jumper of connector J3 on A1 Front Panel Board (see Figure 3-15).																																				
4.	4. Connect signature analyzer CLOCK, START, STOP, and GROUND inputs and setup as shown in Figure 3-16.																																				
5.	<p>Turn on the power supply and use the signature analyzer probe to take the following signatures:</p> <table> <tr> <td>Power:</td> <td>5V = 3395</td> <td></td> </tr> <tr> <td>Microprocessor:</td> <td>AIU3-15 = 3395</td> <td>AIU3-29 = 1029</td> </tr> <tr> <td></td> <td>AIU3-19 = 552U</td> <td>AIU3-30 = 0295</td> </tr> <tr> <td></td> <td>AIU3-20 = 954C</td> <td>AIU3-31 = 0000</td> </tr> <tr> <td></td> <td>AIU3-21 = A552</td> <td>AIU3-32 = 3395</td> </tr> <tr> <td></td> <td>AIU3-22 = 2954</td> <td>AIU3-33 = 0008</td> </tr> <tr> <td></td> <td>AIU3-23 = 0A55</td> <td>AIU3-34 = 040A</td> </tr> <tr> <td></td> <td>AIU3-24 = 3395</td> <td>AIU3-35 = 0102</td> </tr> <tr> <td></td> <td>AIU3-25 = 3395</td> <td>AIU3-38 = 0002</td> </tr> <tr> <td></td> <td>AIU3-26 = 0000</td> <td>AIU3-39 = 0020</td> </tr> <tr> <td></td> <td>AIU3-27 = 0000</td> <td>AIU3-42 = 3395</td> </tr> <tr> <td></td> <td>AIU3-28 = 40A5</td> <td></td> </tr> </table>	Power:	5V = 3395		Microprocessor:	AIU3-15 = 3395	AIU3-29 = 1029		AIU3-19 = 552U	AIU3-30 = 0295		AIU3-20 = 954C	AIU3-31 = 0000		AIU3-21 = A552	AIU3-32 = 3395		AIU3-22 = 2954	AIU3-33 = 0008		AIU3-23 = 0A55	AIU3-34 = 040A		AIU3-24 = 3395	AIU3-35 = 0102		AIU3-25 = 3395	AIU3-38 = 0002		AIU3-26 = 0000	AIU3-39 = 0020		AIU3-27 = 0000	AIU3-42 = 3395		AIU3-28 = 40A5	
Power:	5V = 3395																																				
Microprocessor:	AIU3-15 = 3395	AIU3-29 = 1029																																			
	AIU3-19 = 552U	AIU3-30 = 0295																																			
	AIU3-20 = 954C	AIU3-31 = 0000																																			
	AIU3-21 = A552	AIU3-32 = 3395																																			
	AIU3-22 = 2954	AIU3-33 = 0008																																			
	AIU3-23 = 0A55	AIU3-34 = 040A																																			
	AIU3-24 = 3395	AIU3-35 = 0102																																			
	AIU3-25 = 3395	AIU3-38 = 0002																																			
	AIU3-26 = 0000	AIU3-39 = 0020																																			
	AIU3-27 = 0000	AIU3-42 = 3395																																			
	AIU3-28 = 40A5																																				
6.	After completing the tests, be sure to return the J3 jumper to its original position.																																				

**Table 3-7. Secondary Interface SA Test**

<p><b>Description:</b> These signatures check the secondary microprocessor A5U504.  <b>Valid A5U504 ROM Firmware Revision:</b> A.01.04  <b>Test Setup:</b> See Figure 3-17.</p>																																									
1. Turn off the power supply and remove the top cover.																																									
2. To obtain a setup that allows access to components and test points on the A5 Control Board, follow the procedure given in Table 3-3 under "A5 Control Board Setup".																																									
3. Connect signature analyzer CLOCK, START, STOP, and GROUND inputs and setup as shown in Figure 3-15.																																									
4. To place the secondary interface in the SA mode, turn on the power supply while momentarily (for 2 seconds) shorting A5U504-1 to A5U504-20 (common).																																									
5. Use the signature analyzer probe to take the following signatures:																																									
Power:	5V = IC4C																																								
Microprocessor:	<table border="0"> <tr> <td>A5U504-1 = F77H</td> <td>A5U504-21 = 0C98</td> </tr> <tr> <td>A5U504-2 = C98P</td> <td>A5U504-22 = 5PC7</td> </tr> <tr> <td>A5U504-3 = 1573</td> <td>A5U504-23 = 0000</td> </tr> <tr> <td>A5U504-4 = P42A</td> <td>A5U504-24 = 6CAP</td> </tr> <tr> <td>A5U504-5 = UHF8</td> <td>A5U504-25 = A339</td> </tr> <tr> <td>A5U504-6 = F5UC</td> <td>A5U504-26 = A319</td> </tr> <tr> <td>A5U504-7 = UH8C</td> <td>A5U504-27 = A339</td> </tr> <tr> <td>A5U504-8 = 23UC</td> <td>A5U504-28 = 0C98</td> </tr> <tr> <td>A5U504-9 = 0000</td> <td>A5U504-29 = IC4C</td> </tr> <tr> <td>A5U504-10 = IC4C</td> <td>A5U504-30 = 0000</td> </tr> <tr> <td>A5U504-11 = IC4C</td> <td>A5U504-31 = IC4C</td> </tr> <tr> <td>A5U504-12 = C76F</td> <td>A5U504-32 = 0000</td> </tr> <tr> <td>A5U504-13 = U042</td> <td>A5U504-33 = 0000</td> </tr> <tr> <td>A5U504-14 = 2189</td> <td>A5U504-34 = IC47</td> </tr> <tr> <td>A5U504-15 = IC4C</td> <td>A5U504-35 = 0000</td> </tr> <tr> <td>A5U504-16 = IC45</td> <td>A5U504-36 = 0UPU</td> </tr> <tr> <td>A5U504-17 = 0010</td> <td>A5U504-37 = UF7P</td> </tr> <tr> <td>A5U504-18 = IC4C</td> <td>A5U504-38 = 347F</td> </tr> <tr> <td>A5U504-19 = IC4C</td> <td>A5U504-39 = CP47</td> </tr> <tr> <td>A5U504-20 = 0000</td> <td>A5U504-40 = IC4C</td> </tr> </table>	A5U504-1 = F77H	A5U504-21 = 0C98	A5U504-2 = C98P	A5U504-22 = 5PC7	A5U504-3 = 1573	A5U504-23 = 0000	A5U504-4 = P42A	A5U504-24 = 6CAP	A5U504-5 = UHF8	A5U504-25 = A339	A5U504-6 = F5UC	A5U504-26 = A319	A5U504-7 = UH8C	A5U504-27 = A339	A5U504-8 = 23UC	A5U504-28 = 0C98	A5U504-9 = 0000	A5U504-29 = IC4C	A5U504-10 = IC4C	A5U504-30 = 0000	A5U504-11 = IC4C	A5U504-31 = IC4C	A5U504-12 = C76F	A5U504-32 = 0000	A5U504-13 = U042	A5U504-33 = 0000	A5U504-14 = 2189	A5U504-34 = IC47	A5U504-15 = IC4C	A5U504-35 = 0000	A5U504-16 = IC45	A5U504-36 = 0UPU	A5U504-17 = 0010	A5U504-37 = UF7P	A5U504-18 = IC4C	A5U504-38 = 347F	A5U504-19 = IC4C	A5U504-39 = CP47	A5U504-20 = 0000	A5U504-40 = IC4C
A5U504-1 = F77H	A5U504-21 = 0C98																																								
A5U504-2 = C98P	A5U504-22 = 5PC7																																								
A5U504-3 = 1573	A5U504-23 = 0000																																								
A5U504-4 = P42A	A5U504-24 = 6CAP																																								
A5U504-5 = UHF8	A5U504-25 = A339																																								
A5U504-6 = F5UC	A5U504-26 = A319																																								
A5U504-7 = UH8C	A5U504-27 = A339																																								
A5U504-8 = 23UC	A5U504-28 = 0C98																																								
A5U504-9 = 0000	A5U504-29 = IC4C																																								
A5U504-10 = IC4C	A5U504-30 = 0000																																								
A5U504-11 = IC4C	A5U504-31 = IC4C																																								
A5U504-12 = C76F	A5U504-32 = 0000																																								
A5U504-13 = U042	A5U504-33 = 0000																																								
A5U504-14 = 2189	A5U504-34 = IC47																																								
A5U504-15 = IC4C	A5U504-35 = 0000																																								
A5U504-16 = IC45	A5U504-36 = 0UPU																																								
A5U504-17 = 0010	A5U504-37 = UF7P																																								
A5U504-18 = IC4C	A5U504-38 = 347F																																								
A5U504-19 = IC4C	A5U504-39 = CP47																																								
A5U504-20 = 0000	A5U504-40 = IC4C																																								
6. After completing the tests, be sure to return the J3 jumper to its original position.																																									

---

**Note** After completing this test, you can exit the SA mode only by performing a power-on reset.

---



---

## Post-Repair Calibration

### When Required

Calibration is required annually and also whenever certain components are replaced. If components in any of the circuits listed below are replaced, the supply must be recalibrated.

---

**Note** For calibration procedures, see Appendix A of the Operating Manual.

---

Location	Component
A10 Control Board	CV/CC DACs/operational amplifiers, CV/CC control circuit amplifiers, readback DAC/operational amplifier, readback comparators.
A1 Front Panel Assy	A1 Front Panel Board or EEPROM AIU6. <b>Note:</b> If either of these front panel components is replaced, the power supply must first be reinitialized before calibration (see "EEPROM Initialization" ).

### Inhibit Calibration Jumper

If **CAL DENIED** appears on the display when front panel calibration is attempted (or error code 1 occurs when HP-IB calibration is attempted on a Systems Supply), the INHIBIT CAL jumper (see Figure 3-15) is installed. This prevents the power supply calibration from being changed. To calibrate the power supply first move this jumper from the INHIBIT CAL position to the NORM position.

### Calibration Password

In order to enter the calibration mode, you must use the correct password as described in Appendix A of the Operating Manual. As shipped from the factory, the supply's model number (e.g., "6681") is the password. If you use an incorrect password, **PASSWD ERROR** appears on the display during front panel calibration, or error code 2 occurs during HP-IB calibration, and the calibration mode is disabled. If you do not know the password, you can recover the calibration function by restoring the preset factory calibration constants as described below.

### Restoring Factory Calibration Constants

This procedure allows you to recover the factory calibration constants. The ability to do this allows you to operate the power supply for troubleshooting and/or to recalibrate it as required. To restore the original factory calibration constants, proceed as follows:

1. Turn off the supply and remove the top cover.
2. Move the jumper in test header J3 on the A1 Front Panel Board from the **NORM** to the **FACTORY PRESET CAL** position (see Figure 3-15).
3. Turn on the power supply and note that **ADDR 5** and then **PWR ON INIT** appear briefly on the front panel display.
4. When **PWR ON INIT** no longer appears, the supply's factory calibration constants have been restored and the password has been changed to 0. There is no longer any password protection. You can now turn off the supply and restore the calibration jumper to the **NORM** position (see Figure 3-15).
5. Turn on the supply. You may now set a new password (if desired) and recalibrate the power supply.

---

## EEPROM Initialization

EEPROM AIU6 on the A1 Front Panel Board stores the supply's HP-IB address, model number, and constants required to program and calibrate the power supply. If either the front panel board or the EEPROM is replaced, the power supply must be reinitialized with the proper constants by running the program listed in Figure 3-18.

When the program pauses and asks you to make a selection, respond as follows:

### **Initialization (I) or Factory Preset Replacement (F)? I**

After the power supply has been initialized, it must be calibrated as described in Appendix A of the Operating Manual. After calibration, transfer the new calibration constants to the EEPROM's "Factory Cal" locations as described next.

---

## Transferring Calibration Constants To Factory Preset Locations

A newly initialized and calibrated power supply has calibration constants in operating locations but does not have the new factory calibration constants stored in EEPROM. This procedure transfers the calibration constants into the EEPROM FACTORY PRESET CAL locations by running the program listed in Figure 3-18.

When the initialization program pauses and asks you to make a selection, respond as follows:

### **Initialization (I) or Factory Preset Replacement (F)? F**

The new calibration constants will then be stored. Pre-initialized and tested A1 Front Panel boards are available for Analog Programmable "bench" series supplies. (See Chapter 5, Table 5-4 for part numbers.)

A Bench Series Supply can be initialized and the new Factory Preset calibration constants loaded by temporarily replacing the A2 Isolator board with an A2 HPIB board. Then follow the instructions above for "EEPROM INITIALIZATION" and also "TRANSFERRING CALIBRATION CONSTANTS TO THE FACTORY PRESET LOCATIONS" described above.

After the supply has been Initialized, Calibrated, and the new Factory Presets stored, remove the HPIB board and reinstall the original Isolator board.

```

10 ! Program to initialize EPROM or move factory preset data in 668xA
20 ! power supplies.
30 ! RE-STORE " INIT_668X"
40 ! Rev A.00.00 dated 09 Nov 1993
50 !
60 DIM Init_data(1:49),Model$(5),Idn$(21),Cal_data$(40)
70 INTEGER Addr(1:49),Length(1:49)
80 ASSIGN @Ps TO 705 ! Supply must be at address 705
90 CLEAR SCREEN
100 !
110 Eprom_data_addr: ! Data address
120 DATA 2,6,10,14,18,19,20,24,28,32
130 DATA 36,37,38,42,46,50,54,55,56,57
140 DATA 64,68,72,76,80,116,152,153,154,155
150 DATA 156,158,160,162,163,164,165,166,167,168
160 DATA 169,170,171,172,174,176,180,184,188
170 !
180 Eprom_data_len: ! Data for word length
190 DATA 4,4,4,4,1,1,4,4,4,4
200 DATA 1,1,4,4,4,4,1,1,1,1
210 DATA 4,4,4,4,4,1,1,1,1,1
220 DATA 2,2,2,1,1,1,1,1,1,1
230 DATA 1,1,1,2,1,4,4,4,4
240 !
250 Eprom_data_6680: ! EEPROM data for 6680A
260 DATA 729,71,5.125,0,83,0,4.235,72,895,0
270 DATA 98,3,36,17,6.25,0,83,255,20,10
280 DATA 6680,708,94,4.13,92,128,5,255,0,0
290 DATA 1296,6680,0,20,180,20,180,175,33,98
300 DATA 115,30,20,1,58,.002701,.2,.0017346,10.2286
310 !
320 Eprom_data_6681: ! EEPROM data for 6681A
330 DATA 463,75,8.19,0,83,0,6.333,70,592,0
340 DATA 98,3,22.16,17.75,10.0,0,83,255,20,10
350 DATA 6681,430,95,6.3645,92,128,5,255,0,0
360 DATA 1296,6681,0,20,180,20,180,175,33,98
370 DATA 115,30,20,1,58,.002701,.2,.0017346,10.2286
380 !
390 Eprom_data_6682: ! EEPROM data for 6682A
400 DATA 175,74,21.5,0,83,0,15,73,246,0
410 DATA 98,21,8.7,10,26.3,0,83,255,20,10
420 DATA 6682,162,96,15,96,128,5,255,0,0
430 DATA 1296,6682,0,20,180,20,180,175,33,98
440 DATA 115,30,20,1,127,.002701,.2,.000307,10.25
450 !
460 Eprom_data_6683: ! EPROM data for 6683A
470 DATA 116,74,32.8,0,83,0,23,75,164,0
480 DATA 98,21,5.5,10,40.0,0,83,255,20,10
490 DATA 6683,108,96,23,97,128,5,255,0,0
500 DATA 1296,6683,0,20,180,20,180,175,33,98

```

**Figure 3-17. Initialization and Factory Preset Replacement Program Listing (Sheet 1 of 5)**

```

510 DATA 115,30,20,1,127,.002701,.2,.00042,10.25

```

```

520      !
530 Eprom_data_6684: !                               ! EEPROM data for 6684A
540     DATA 93,74,41,0,83,0,29,70,131,0
550     DATA 98,21,4.6,10,50,0,83,255,20,10
560     DATA 6684,87,97,28,93,128,5,255,0,0
570     DATA 1296,6684,0,20,180,20,180,175,33,98
580     DATA 115,30,20,1,127,.002701,.2,.000333,10.234375
590     !
600     !
610     INPUT "Input Power Supply model number.  Example:""6681A""",Model$
620     CLEAR SCREEN
630     !
640     RESTORE Eprom_data_addr
650     !
660     FOR I=1 TO 49
670         READ Addr(I)
680     NEXT I
690     !
700     RESTORE Eprom_data_len
710     !
720     FOR I=1 TO 49
730         READ Length(I)
740     NEXT I
750     !
760     SELECT TRIM$(UPC$(Model$))                       ! Delete leading/trailing zeros and set to uppercase
770     CASE "6680A"
780         RESTORE Eprom_data_6680
790     CASE "6681A"
800         RESTORE Eprom_data_6681
810     CASE "6682A"
820         RESTORE Eprom_data_6682
830     CASE "6683A"
840         RESTORE Eprom_data_6683
850     CASE "6684A"
860         RESTORE Eprom_data_6684
870     !
880     CASE ELSE
890         PRINT "Model number not found. Program is for models"
900         PRINT "HP 6680A, 6681A, 6682A, 6683A and 6684A only"
910     STOP
920     END SELECT
930     !
940     FOR I=1 TO 49                                     ! Read model dependent data
950         READ Init_data(I)
960     NEXT I
970     !
980     OUTPUT @Ps;"*CLS"                                ! Clears power supply registers
990     !
1000    OUTPUT @Ps;"CAL;STATE ON,"                      ! Turn on cal mode, "0" passcode
1010    !

```

**Figure 3-17. Initialization and Factory Preset Replacement Program Listing (Sheet 2 of 5)**

```

1020    GOSUB Ps_error                                  ! Error if passcode is not "0"!
1030    IF Err THEN

```

```

1040 OUTPUT @Ps;"*IDN?" ! Get data from model # location
1050 ENTER @Ps;Idn$
1060 Model=VAL(Idn$[POS(Idn$,"")+1] )
1070 ELSE
1080 GOTO Start
1090 END IF
1100 !
1110 OUTPUT @Ps;"CAL:STATE ON,":Model ! Turn on cal mode, passcode =
1120 ! data at model number location
1130 !
1140 GOSUB Ps_error ! Error if passcode is not same as
1150 ! data at model # location
1160 IF Err THEN
1170 OUTPUT @Ps;"CAL:STATE ON,":Model$[1,4] ! Turn on cal mode, passcode =
1180 ! model #
1190 GOSUB Ps_error
1200 IF Err THEN
1210 PRINT "Change pass code to the power supply model # or zero then restart the program."
1220 STOP
1230 ELSE
1240 GOTO Start
1250 END IF
1260 END IF
1270 !
1280 Start: !
1290 !
1300 !
1310 INPUT "Select Initialization (I) or Factory preset replacement (F).",Sel$
1320 CLEAR SCREEN
1330 SELECT (UPC$(Sel$))
1340 CASE "I" ! Select Initialization
1350 GOTO Init_eeprom
1360 CASE "F" ! Select install new factory data
1370 GOTO Fact_preset
1380 CASE ELSE
1390 BEEP
1400 GOTO Start
1410 END SELECT
1420 !
1430 Init_eeprom: !
1440 PRINT "Initializing EEPROM"
1450 !
1460 FOR I=1 TO 49
1470 OUTPUT @Ps;"DIAG:EEPR ";Addr(I);";Length(I);";Init_data(I)
1480 NEXT I
1490 GOTO Cal_off
1500 !
1510 !
1520 Fact_preset: !

```

**Figure 3-17. Initialization and Factory Preset Replacement Program Listing (Sheet 3 of 5)**

```

1530 CLEAR SCREEN
1540 PRINT "This program should ONLY be completed if your power supply"

```

```

1550 PRINT "EEPROM has been replaced or a component that will effect"
1560 PRINT "the calibration AND the alignment of voltage, overvoltage"
1570 PRINT "and current is complete AND unit has passed the performance"
1580 PRINT "test.           Enter C to continue, any other key to abort."
1590 INPUT Cont_prog$
1600 IF (UPC$(Cont_prog$))<>"C" THEN GOTO Cal_off
1610 !
1620 CLEAR SCREEN
1630 PRINT "Transferring calibration data to factory preset locations."
1640 !
1650 Fact_cal_sour:      ! Address of factory calibration data source
1660 DATA 2,6,68,72,20,24,76,80,150
1670 !
1680 Fact_cal_dest      :  ! Address of factory calibration data destination
1690 DATA 84,88,92,96,100,104,108,112,116
1700 !
1710 Fact_cal_len:      ! Length of factory calibration data
1720 DATA 4,4,4,4,4,4,4,4,1
1730 !
1740 RESTORE Fact_cal_sour
1750 FOR I=1 TO 9
1760 READ Cal_sour_addr(I)
1770 NEXT I
1780 !
1790 RESTORE Fact_cal_dest
1800 FOR I=1 TO 9
1810 READ Cal_dest_addr(I)
1820 NEXT I
1830 !
1840 RESTORE Fact_cal_len
1850 FOR I=1 TO 9
1860 READ Cal_length(I)
1870 NEXT I
1880 !
1890 FOR I=1 TO 9                                ! Locations of good data
1900 OUTPUT @Ps;"DIAG:EEPR? ";Cal_sour_addr(I);",";Cal_length(I) ! Read good data
1910 ENTER @Ps;Cal_data$                          ! Enter good data
1920 OUTPUT @Ps;"DIAG:EEPR";Cal_dest_addr(I);",";Cal_length(I);",";Cal_data$
! Write good data to factory preset locations
1930 NEXT I
1940 !
1950 !
1960 Cal_off
1970 CLEAR SCREEN
1980 OUTPUT @Ps;"CaL:STATE OFF"                   ! Turn off cal mode
1990 !
2000 GOSUB Ps_error                               ! Check for errors

```

**Figure 3-17. Initialization and Factory Preset Replacement Program Listing (Sheet 4 of 5)**

```

2010 IF Err THEN
2020 PRINT "An error occurred during the EEPROM read/write, Check for"
2030 PRINT "programming errors. Initialization data may be incorrect."
2040 STOP

```

```

2050 END IF
2060 !
2070 PRINT "Operation complete. Program stopped."
2080 STOP
2090 !
2100 Ps_error: ! Error handling subroutine
2110 OUTPUT @Ps;"SYST:ERR?" ! Check for errors
2120 ENTER @Ps;Err
2130 RETURN
2140 !
2150 END

```

**Figure 3-17. Initialization and Factory Preset Replacement Program Listing (Sheet 5 of 5)**

---

## Disassembly Procedures

### WARNING

**Shock Hazard:** To avoid the possibility of personal injury, remove the power supply from service before removing the top cover. Turn off the ac power and disconnect the line cord, HP-IB cable, load leads, and remote sense leads before attempting any disassembly. Any disassembly work must only be performed by a qualified support technician.

Observe that the DC RAIL assembly LEDs (DS420 & DS421) are fully extinguished (no live voltages present) before attempting any disassembly work. Any disassembly work must only be performed by a qualified support technician.

---

Cable connections are shown in Figure 6-2 of Chapter 6 and component part numbers are given in Chapter 5. Reassembly procedures are essentially the reverse of the corresponding disassembly procedures.

## Tools Required

- ⌘ TORX screwdriver size T-15 (for most all retaining screws).
- ⌘ TORX screwdriver size T-20 (for power supply carry straps).
- ⌘ Seven (7) mm metric hex driver (to remove HP-IB read connector).
- ⌘ Pencil, paper, and labels to make notes to aid in the reinstallation of components.
- ⌘ Work at a static-free station such as a table covered with static-dissipative laminate or with a conductive table mat (HP P/N 9300-0797, or equivalent) using a conductive wrist strap where necessary, such as, HP P/N 9300-0969 or 9300-0970.

## Top Cover

1. Remove the four screws that secure the carrying straps (two TORX 20 screws on each side). These same screws secure the cover to the chassis.
2. Spread the bottom rear of the cover, and then pull the cover backwards towards the rear of the power supply to disengage it from the front panel.

### WARNING

**Shock Hazard:** Hazardous voltage can exist inside the power supply even after it has been turned off.

Check the INPUT RAIL LED (A4CR402) under the RFI shield (see Figure 3-18 end of this section for LED location). If the LED is on, there is still hazardous voltage inside the supply. Wait until the LED goes off (*approximately 7 minutes after power is removed*) before proceeding.

---

## Removing Protective RFI Shield (Galvanized Sheet Metal)

Once you remove the top cover of the power supply, you will see the RFI galvanized sheet metal cover preventing the power supply from emanating RFI fields. The RFI shield covers most components and circuit boards, as well as, many of the chassis-mounted components. You must remove this shield in order to gain access to the inside of the power supply. Remove the shield as follows:

1. There are approximately 21 screws holding the cover to the frame.
2. There are two screws at the top of the shield that secure a retaining clip for the HP-IB board. You do not need to remove these screws, simply loosen the screws and slide the HP-IB retaining clip backwards free of the HP-IB board.
3. Remove all shield securing screws using a TORX T-15 screwdriver and save for later reinstallation .
4. Lift the RF shield out of the chassis.
5. When DC RAIL LEDs are extinguished, it is safe to work inside the power supply. (See Warning note above.)

---

### Note

The following procedures describe the removal of most of the circuit boards within the power supply. Once the HP-IB board is removed, you will have access to the A4 AC Input Assembly and the A5 DC Rail Assembly. Similarly, once the A10 control board is removed along with the Rectifier HS you will have access to other components and boards within the supply.

It is recommended that when you disconnect any wires and/or cable connectors you should immediately label them to simplify their reinstallation later.

---

## HP-IB Board

To remove the HP-IB board, disconnect the cables from the following connectors at the HP-IB board:

1. Disconnect the cable going to connector P101.
2. Disconnect phone cable going to J107.
3. Disconnect phone cable going to J107.
4. Disconnect phone cable going to J108.
5. Remove two (2) holding screws at rear of chassis holding HP-IB board in place.
6. Using a 7 mm driver, remove the two (2) screws holding the HP-IB connector at rear of chassis.
7. The HP-IB board can now be lifted out from the chassis.

## A4 AC Input Assembly

To remove the A4 AC Input Board first remove the HP-IB board then disconnect these cables from the following connectors at the HP-IB board:

1. Disconnect the cables going to connector J417 and J420.
2. Disconnect the cable going to connector J419.
3. Remove the three (3) fuse assemblies inside rear of power supply to free the wires going to E400, E401, and E402 on the AC Input Board.
4. Remove the holding screw at the center of board just to the left of the 3-phase choke.
5. Disconnect phone cable going to J108.
6. Slide the board to the right and lift out.
7. Other wires going to the board can now be removed/unsoldered.



## A5 DC RAIL Assembly

Disconnect these cables from the following connectors at the A5 DC RAIL board:

1. Disconnect the cables going to four connectors: J430, J431, J432, and J433.
2. Disconnect the cable going to connector J440.
3. Remove the four (4) holding screws TORX T-15 holding the A5 DC RAIL board in place.
4. Lift the board out and remove/desolder any other wires preventing the board from being removed.

## A6 BIAS Assembly

Disconnect the cables from the following connectors at the A6 BIAS Assembly board:

1. Disconnect cables from connectors J809, J821, J830, and J831 on the A6 BIAS Board.
2. Remove two (2) holding screws at top side of board.
3. Slide board upward until board is free of slotted standoffs. There is one of these standoffs at the top of the board and two at the bottom. Wiggle the board slightly to clear all three standoffs then lift the board out.
4. Once the board is free from its restraining standoffs, you can proceed to remove/unsolder any other wires/cables as necessary to remove the A6 BIAS Board entirely.

---

### Note

It is recommended that you label any connectors you disconnect from the A6 BIAS Board to facilitate the reinstallation of these cables/wires back to their correct locations later. If you should have trouble later in determining which cable goes to which connector during reinstallation, refer to the cabling diagram in Chapter 6.

---

## A3 FET Board

Follow this procedure to remove the A3 FET Board:

1. Remove the four (4) holding screws that secure the two black caps over the Rectifier HS assembly.
2. Once these caps are removed, you can remove the Rectifier HS which faces the A3 FET Board.
3. Disconnect two connectors, P430 and P431, at the A5 DC RAIL assembly.
4. Disconnect two connectors P/O cable assemblies P/N 5080-2283, at the A5 DC RAIL assembly.
5. You can now lift out the A3 FET board and remove/unsolder any other wires necessary to fully remove the A3 board.

## A10 Control Assembly

Disconnect the cables from the following connectors at the A10 DC RAIL board:

1. Disconnect the ribbon cable going from to the A6 Bias board. This cable connects to J509 on the A10 board but it is easier to disconnect it at the A6 Bias Board.
2. Disconnect cables from connector J507 (phone) and connectors J510, J511, J512, and J513 on the A10 Control Board.
3. At rear of power supply, remove holding screw directly above fan. This screw holds the frame and A10 control board in place.
4. At rear of power supply unplug connector DIG CNTL from A10 Control Board.
5. Move board to the right and lift board and associated steel frame out of chassis.

## Front Panel Assembly

1. Peel off vinyl trim (one strip on each side of front panel) to access the four screws that secure the front panel assembly to the chassis.
2. Remove the four screws (two on each side) using a size T-10 TORX.
3. Disconnect phone cable W5 from J6 on the A1 Front Panel Board.

4. Record the color code and the location of each of the four wires connected to line switch S1.
5. Disconnect the wires from the switch assembly.
6. Remove the front panel assembly.

## S1 Line Switch

1. Remove Front Panel Assembly and disconnect switch wires as described in that procedure.
2. Release the switch locking tabs by pressing them inward against the body of the switch and removing the switch.

## A1 Front Panel Board

1. Remove the Front Panel Assembly and disconnect the switch as described under "Front Panel Assembly".
2. Disconnect LCD display ribbon cable W2 from J2 on the A1 Front Panel Board.

---

**Note** When reinstalling the LCD ribbon cable, be sure to line up the "stripe" of the ribbon cable with pin 1 on J2.

---

3. Use a small allen wrench (0.050") to loosen the set screws that are inset in the knobs. (These are the AIG1 and AIG2 Voltage/Current control shafts that extend through the front panel.) Remove knobs and shaft bushings.

---

**Note** Be careful not to unscrew the knob set screws too far out as they can easily fall out of the knob and become lost.

---

4. Remove screw (if installed) that secures board to the Front Panel Assembly. The screw is located near J4 on the Front Panel Board.
5. Lift tab (near J6 on front panel board) and slide left to release board from the A1 Front Panel Assembly and remove board.

## A1DSP1 LCD Display

1. Remove the A1 Front Panel Board as described in that procedure.
2. Remove the nuts securing the LCD display to the front panel assembly and remove the LCD and attached ribbon cable (see CAUTION below). (When reinstalling this cable, be sure to line up the cable stripe over the LCD connector pin marked with a square.)

---

**CAUTION**

The display connector is fragile. When removing the cable from the LCD display, carefully rock the cable connector back and forth while gently pulling it back.

---

### A1G1 and A1G2 Rotary Controls

1. Remove the A1 Front Panel Board as described in that procedure.
2. Remove the A1G1 and A1G2 cables from connectors A1J4 and A1J5.
3. Remove nuts securing the A1G1 A1G2 controls to the board and remove controls.

### A1KPD Keypad

1. Remove the A1 Front Panel Board as described in that procedure.
2. With board removed, keypad can easily be lifted out of the Front Panel Assembly.

### Output Bus Boards A7, A81 and A9 & Chassis Components

---

**Note**

To remove the A7 Snubber Board, A8 Fast Sense Assembly, A9 Downprogrammer and other chassis mounted components, first remove the A10 Control Board frame assembly and the two Rectifier Heat Sinks described earlier. Once the heat sinks are removed you will have access to the A7, A8, and A9 boards as well as other chassis mounted components.

Should you have any difficulty in removing power supply components or boards, contact the Hewlett-Packard Support Line for help.

---

**WARNING**

**Shock Hazard:** Hazardous voltage can exist inside the power supply even after it has been turned off. Check the INPUT RAIL LED (A4CR402) under the RFI shield (see Figure 3-18 end of this section for LED location). If the LED is on, there is still hazardous voltage inside the supply. Wait until the LED goes off (*approximately 7 minutes after power is removed*) before proceeding.

---

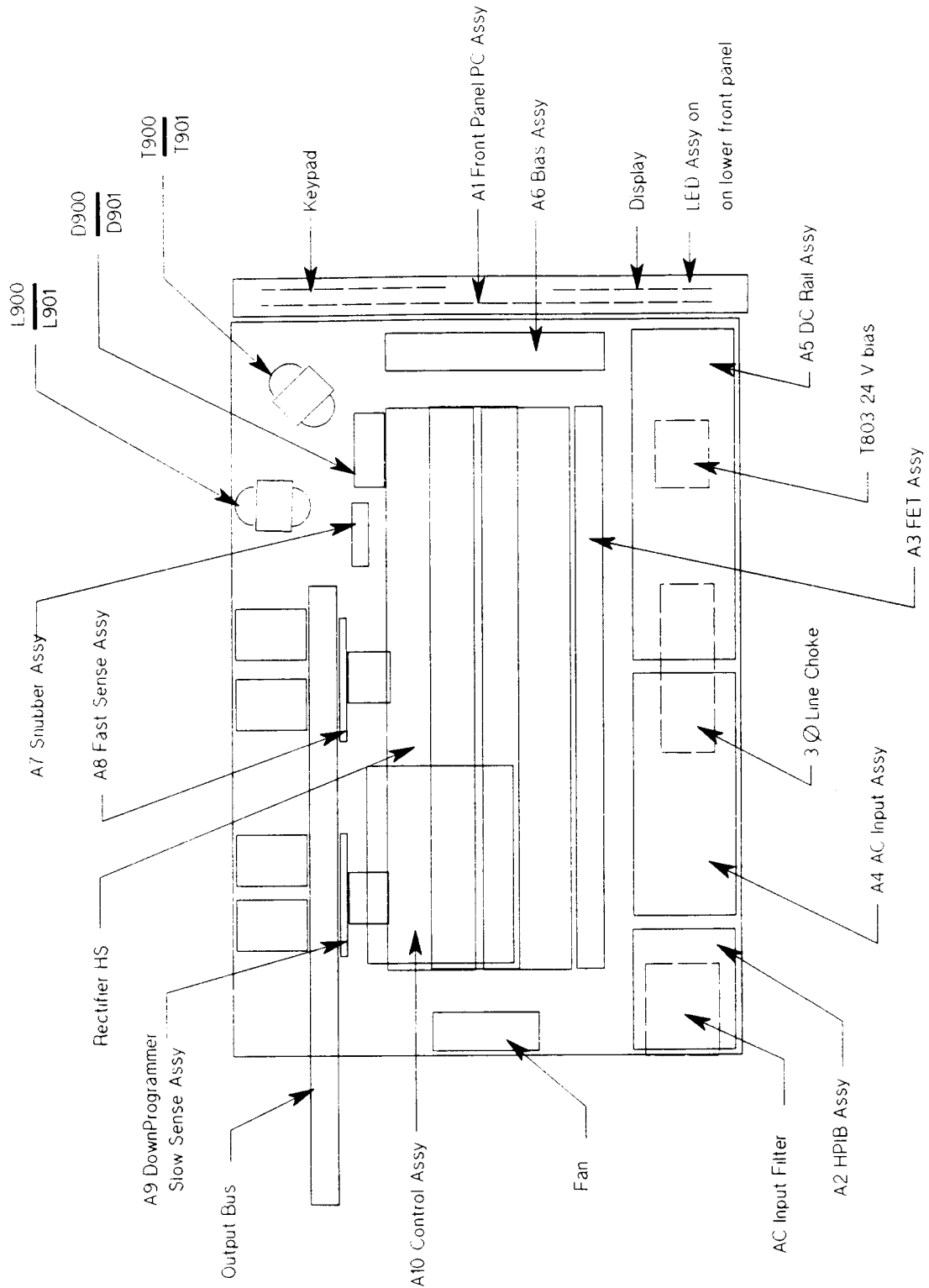

Figure 3-18. Component Locations (Top Cover and RFI Shield Removed)

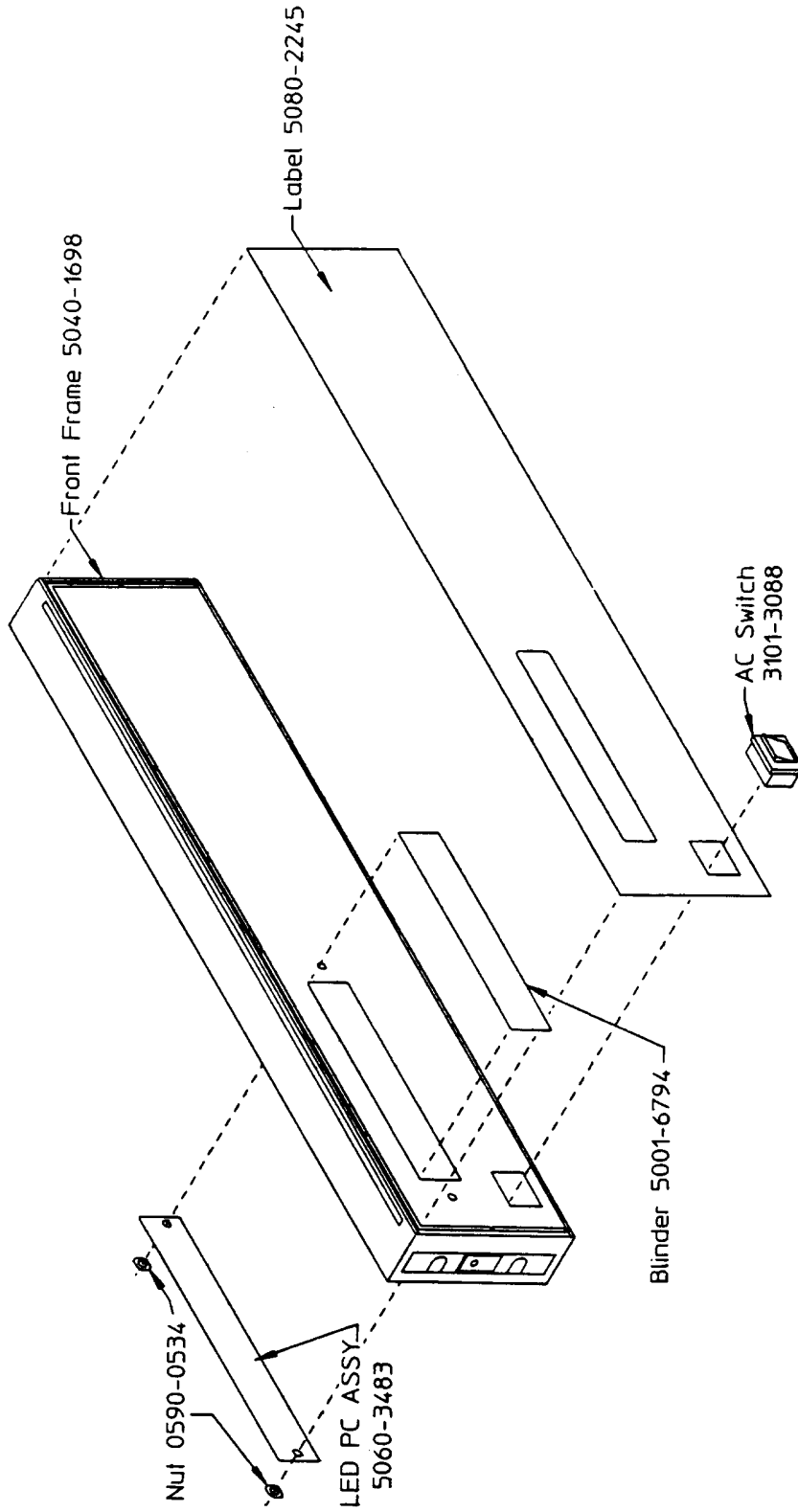

Figure 3-19. 5-Inch Front Panel Frame Assembly

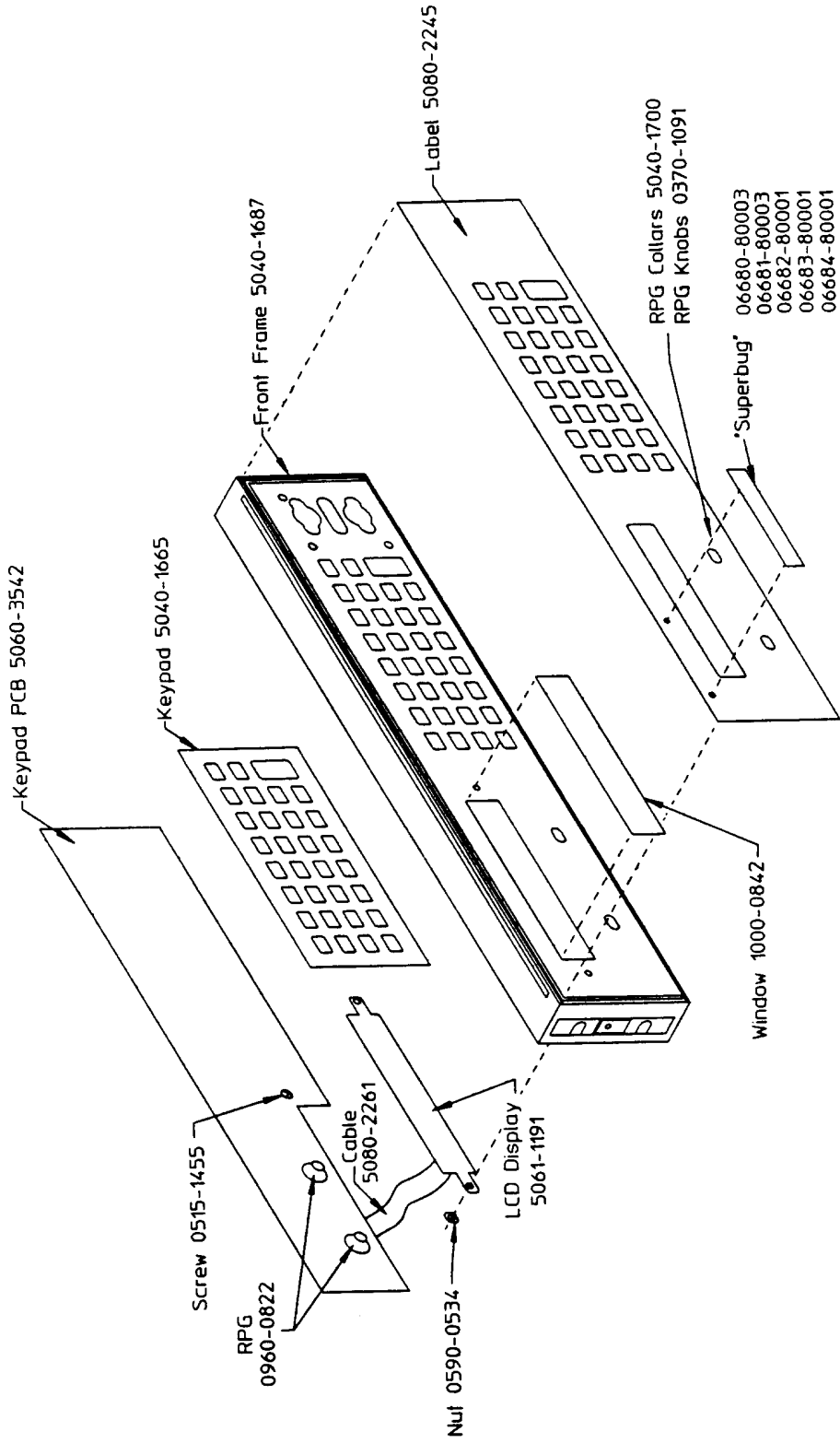

Figure 3-20. 3-Inch Front Panel Frame Assembly

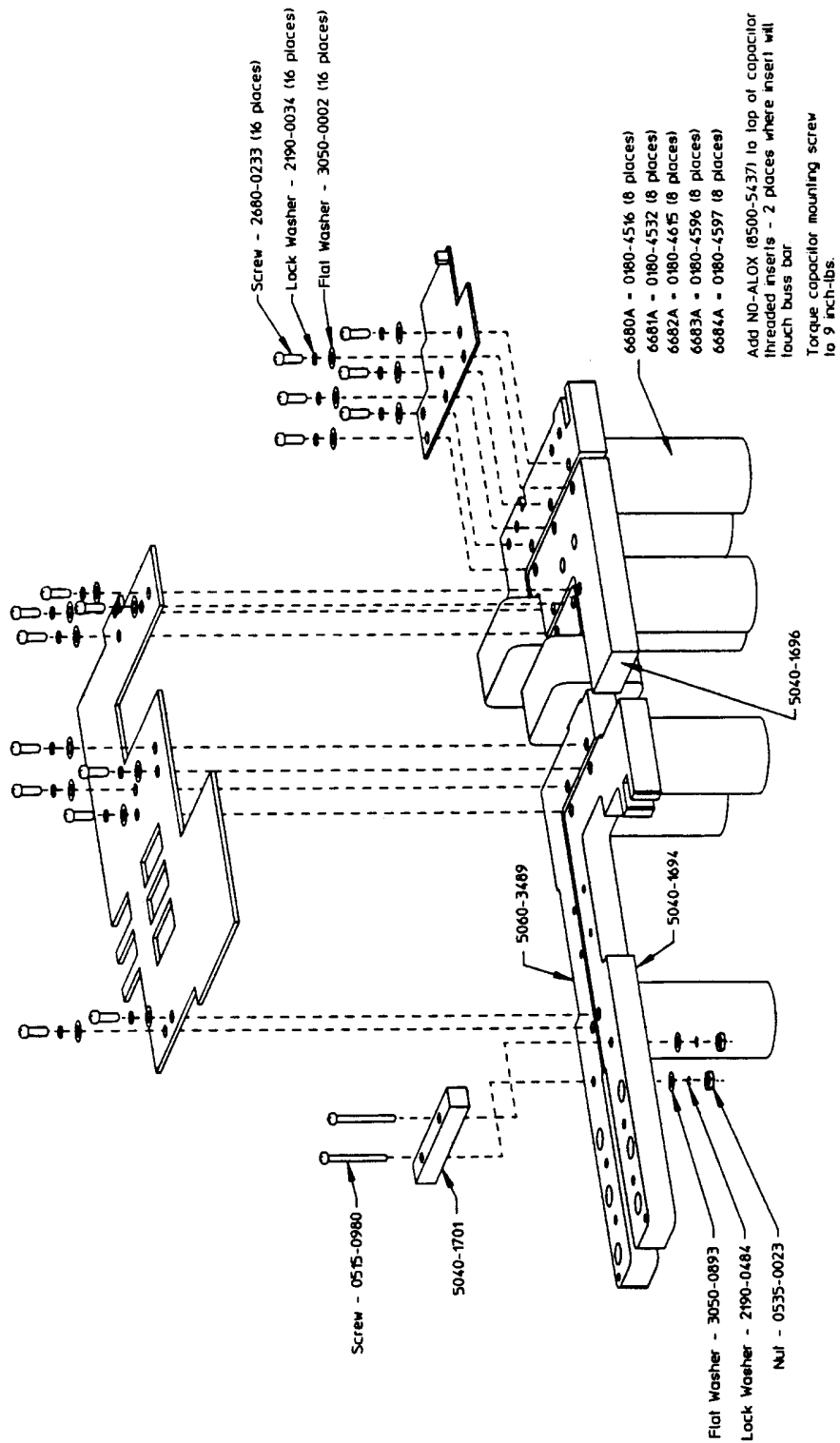

Figure 3-21. Assembly A10, Exploded View

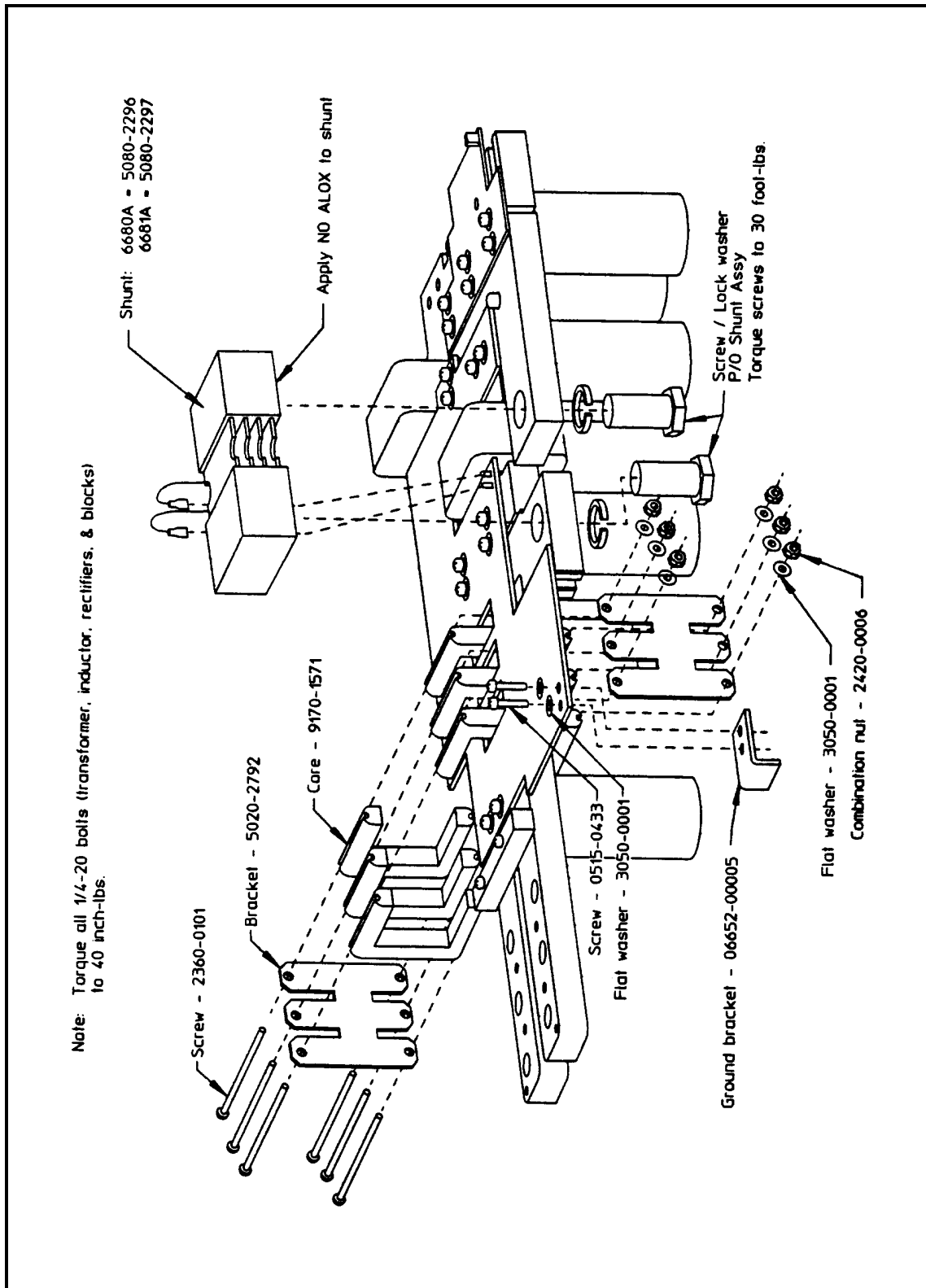

Figure 3-22. Assembly A10, Exploded View (6680A, 6681A)



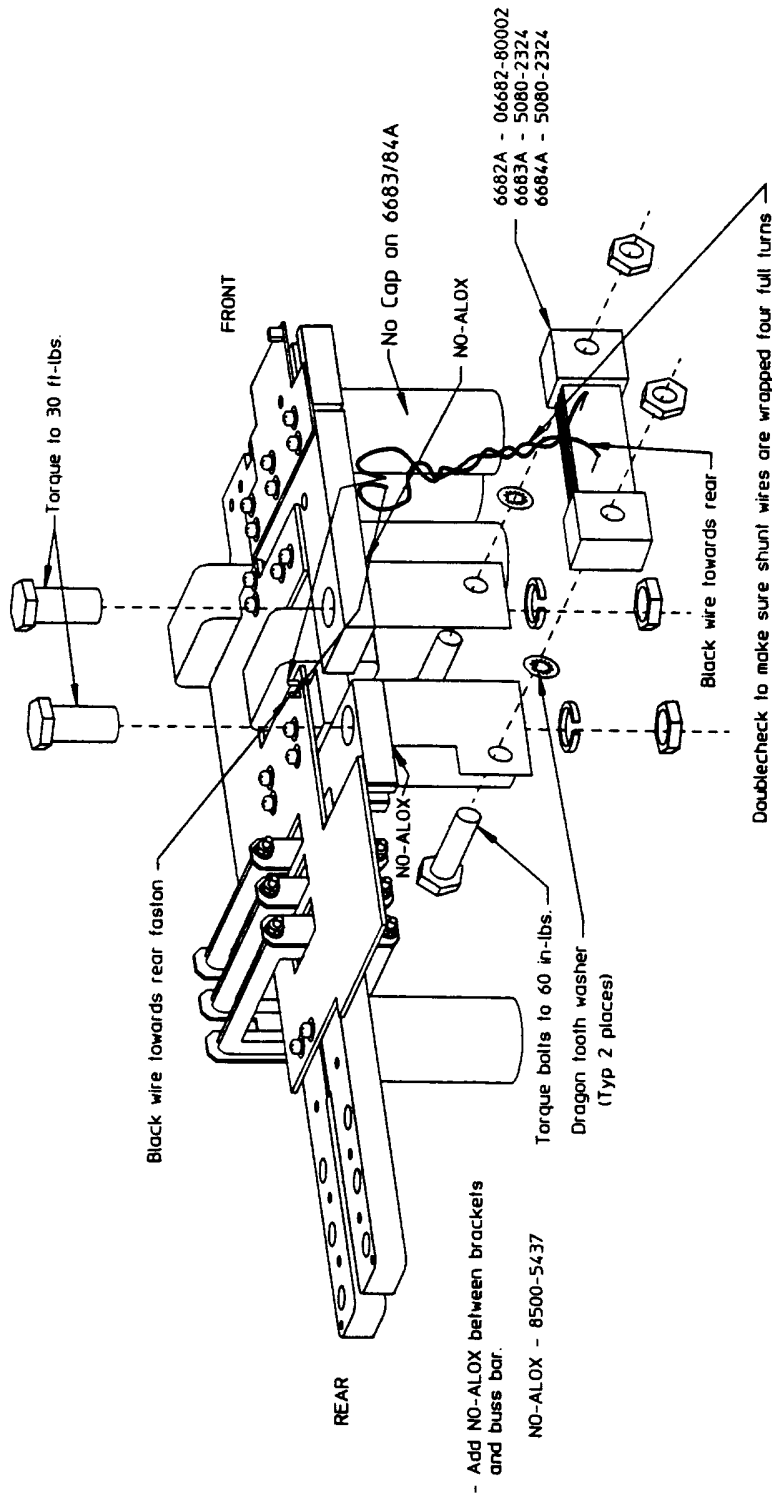

Figure 3-23. Assembly A10, Exploded View (6682A, 6683A, 6684A)

5080-2262 3Ø-Choke

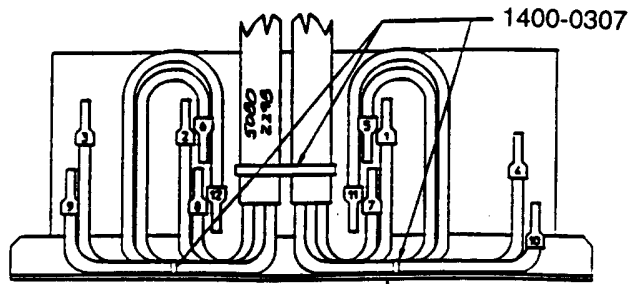
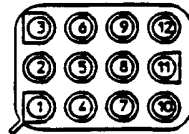

FIGURE 1

EXT	COLOR	EXT	COLOR
1	WHT/GRY	7	VID
2	BWN	8	ORNG
3	WHT/BLK	9	RED
4	WHT	10	WHT/RED
5	BLU	11	GRY
6	BLK	12	WHT/ORNG

TABLE 1



END VIEW OF CONNECTOR  
SCALE: 2X

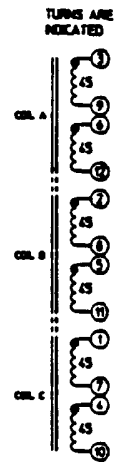

Nut 0535-0023  
Lockwasher 2190-0586  
Flatwasher 3050-1053

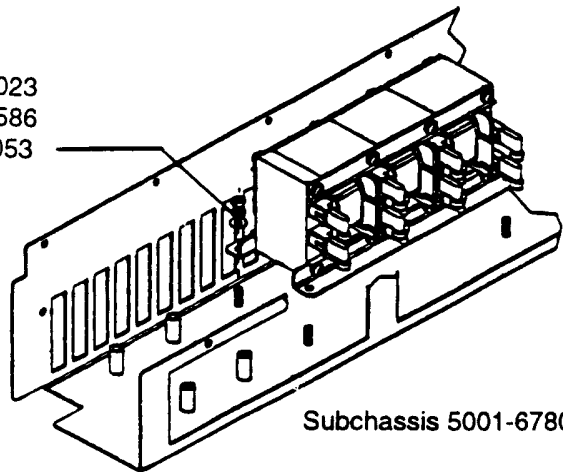

Subchassis 5001-6780

Figure 3-24. Three-Phase Line Choke Subchassis Wiring

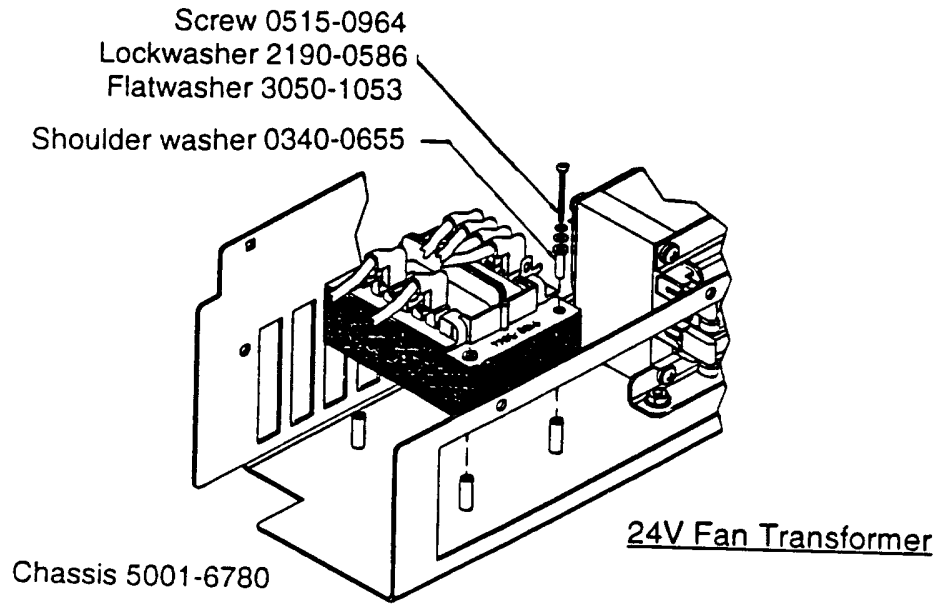
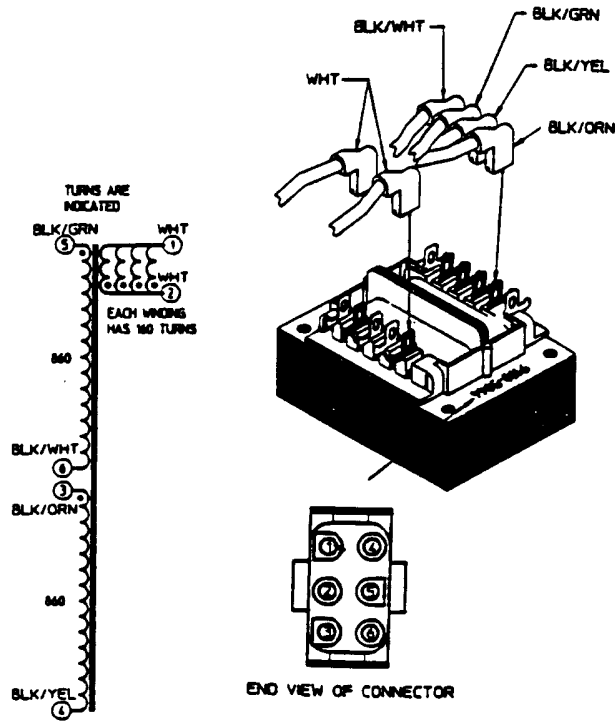

Figure 3-25. 24 Volt Fan Transformer







# Principles Of Operation

---

## Introduction

Figure 4-3 (at the end of this chapter) is a block diagram showing the major circuits within the power supply. The power supply consists of the following circuits:

- A1 Front Panel Board ckts.
- A2 HP-IB ckts.
- A10 Control Board including the secondary interface ckts, CV/CC control ckts, switching/downprogramming control ckts.
- Power circuits on the A4 AC Input Board.
- A3 FET Assembly ckts.
- A5 DC Rail Board ckts.
- Output bus circuits which include the A7 Snubber Board, A8 Slow Sense Board, and A9 Downprogrammer Board ckts.
- Output rectifiers and filter capacitors.
- Ferrite cores mounted on the output bus form the output filter inductors.
- A6 Bias Board supply which supplies low-voltage, low-power, bias voltages where required.

Each block in Figure 4-3 identifies a schematic diagram in Chapter 6 where the circuits are shown in detail. You can refer to the component location diagrams in Chapter 6 to locate specific components mentioned in this description. Chapter 6 also has a cabling diagram showing the circuit board interconnections.

---

## A2 HP-IB Board

Circuits on the A2 HP-IB board provide the interface between the HP-IB controller and the power supply. All communications between the power supply and the HP-IB controller are processed by the HP-IB interface and primary microprocessor circuits on the A2 board.

The primary microprocessor circuits (microprocessor, U114, ROM U106, and RAM U108) decode and execute all instructions and control all data transfers between the HP-IB controller and the Secondary Interface on the A10 Control Board. The primary microprocessor also processes measurement and status data received from the Secondary Interface.

A UART (universal asynchronous receive/transmit) IC (U112) on the A2 board converts data between the primary microprocessor's 8-bit, parallel bus and the serial I/O port. The serial data is transferred between the primary interface and the secondary interface via a programmed GAL (gated array logic) IC (U119) and optical isolator ICs (U110/U111). These ICs isolate the primary interface circuits (referenced to earth ground) from the secondary interface circuits (referenced to power supply common). The GAL IC also provides a serial I/O port to the A1 Front Panel Board to enable front panel control of the power supply.

A serial link interface IC (U109) on the A2 HP-IB Board allows up to sixteen supplies to be connected together and programmed from one HP-IB address. The first supply is the only supply connected directly to the HP-IB controller and is set to the primary HP-IB address. The remaining supplies are set to secondary addresses and are linked (daisy chained) together via the J1/J2 phone jacks at the rear of each supply. The serial link configuration is described in the Power Supply Operating Manual.

A digital control interface on the A2 HP-IB Board provides the following power supply functions:

- Relay link.
- Digital I/O.
- Remote inhibit (INH).
- Discrete fault indicator (FLT).

An optical isolator IC (U113) isolates the FLT output signal common from the external fault circuit common. The desired digital interface function is selected by placing a jumper in a header (J106) on the A2 HP-IB Board. Appendix D in the Power Supply Operating Manual describes how to select one of these functions and how to make the appropriate external connections to the DIG CNTL connector on the supply's rear panel. Another jumper position on the header selects the SA (signature analysis) mode, which is used for troubleshooting (see Chapter 3).

The A2 Board has a bias supply regulator IC (U121) that provides +5V (with respect to earth ground) for the primary interface circuits and the bias voltage for the front panel board circuits, the LCD, and the keypad. The A2 Board also has a line or bias voltage detector IC (U101) that generates a power clear signal (PCLR). This signal initializes certain primary interface and front panel circuits when normal ac line voltage is applied, and also shuts these circuits down when the line voltage drops below the required minimum.

---

## A1 Front Panel Assembly

The power supply A1 Front Panel Assembly contains a circuit board, keypad, liquid crystal display (LCD), and the power on/off switch.

The Front Panel Circuit Board A1 contains microprocessor circuits (microprocessor U3 and ROM U4) that decode and execute all front panel keypad commands. These are transferred to the power supply output via the serial I/O port to the A2 board GAL (gated-array logic) IC and isolators, and to the secondary interface circuits on the A10 Control Board. The front panel microprocessor circuits also process power supply measurement and status data received from the serial I/O port. This data is displayed on the LCD.

IC EEPROM, U6, (electrically-erasable, programmable, read-only memory) on the A1 Front Panel Board stores data and configuration information. This information includes calibration constants, HP-IB address, the present programming language, and model-dependent data such as the minimum and maximum values of voltage and current.

One of the EEPROM storage locations holds a checksum value used to verify the integrity of this EEPROM data. Access to the calibration data in the EEPROM is controlled by the combination of a password and jumper options on a header (J3) located on the A1 board (see Post-Repair Calibration in Chapter 3).

The power supply can be calibrated manually using the front panel keys, or via the HP-IB bus with SCPI (Standard Commands for Programmable Instruments) commands. The calibration procedure is in Appendix A of the Power Supply Operating Manual).

---

## A10 Control Board

The A10 Control Board contains the Secondary Interface, CV/CC Control Circuits, Readback Circuits, PWM Switching Circuits and OV/Downprogramming Circuits. These circuits are shown schematically in the A10 Control Board schematic.

### Secondary Interface (P/O A10 Board)

These circuits are shown in detail on the A10 Control Board schematic and include the Secondary Microprocessor (U506), Programmed GAL (U505), three DAC/OpAmp circuits (U510-U515), Readback Comparator circuits (U516, U517) and OV/Shunt DAC OpAmp circuit, (U520, U521).



The Secondary Microprocessor translates serial data received from the A2 board into parallel 12 bit data. The data bus is connected directly to the four DAC/OpAmp circuits. Under control of the lip the selected DAC converts the bus data into an analog signal. The DAC reference circuit (U503, U504) provides a +10V reference for the CV and CC DACs and a -11.6V reference for the readback DAC. Zener VR501 provides a -6.2V reference for the OV Shunt DAC.

The CV DAC/OpAmp (U510, U513) converts the programmed voltage value from the bus or front panel into the CVPROG signal. CVPROG is sent to the CV Error Amp and compared with the VMON signal to control the magnitude of the output voltage in the CV mode. The range of CVPROG is 0 volts to -10 volts, which corresponds to the zero-to-full-scale output voltage range of the supply.

The CC DAC/OpAmp (U511, U514) converts the programmed current value from the bus or front panel into the CCPROG signal. CCPROG is sent to the CC Error Amp and is compared with the IMON signal to control the magnitude of the output current in the CC mode. The range of CCPROG is 0 volts to -10 volts, which corresponds to the zero-to-full-scale output current range of the supply.

The Readback Comparators (U516, U517) operate with the Readback DAC/OpAmp (U512, U515) to return the following signals to the  $\mu$ P:

- The monitored output voltage (VMON).
- The monitored output current (IMON).
- The ambient temperature (AMB\_SENSE).
- The programmed voltage value (CVPROG).
- The programmed current value (CCPROG).
- The fan detector (FAN\_DEW).

The readback DAC circuit is controlled by the  $\mu$ P to successively approximate (to 12-bit resolution) the value of each signal monitored. The CVPROG and CCPROG signals are used during selftest to check DAC/OpAmp operation. The  $\mu$ P monitors the fan speed and ambient temperature and generates the FAN\_PWM control signal to adjust fan speed depending upon the ambient temperature measured internally in the power supply.

A dual DAC, Shunt-Trim/OV, Amplifier circuit (U520, U521) performs two functions. One is to convert the programmed overvoltage value from the bus or front panel into the OVREF signal. The OVREF signal is compared by U502 with the output voltage. Second, the Shunt Trim DAC calibrates the IMON signal by sampling the current flowing through current-sense resistor (R900) on the output power bus together with the TRIM input signal.

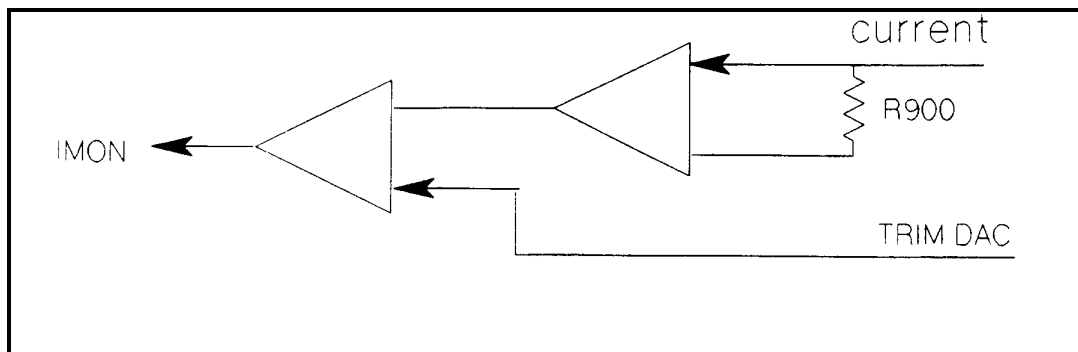

**Figure 4-1. AC Calibration of IMON**

During power initiation, the secondary processor generates PWM DISABLE to the power supply's output off for 10 seconds. After 10 seconds PWM DISABLE is removed and the supply's output can be programmed.

CV/CC Control (P/O A10 Board) These circuits are shown in detail on the A10 Control Board schematic and include the CV (constant voltage) and CC (constant current) control loops. The power supply must act as either a CV or CC supply for any value of load impedance. Switching between CV and CC is done automatically by the CV/CC control circuits at a value of load impedance equal to the ratio of the programmed voltage value to the programmed current value.

A low-level CV or CC signal is generated by the applicable status comparator (P/O U502) and returned to the secondary processor to indicate that the corresponding mode, CV or CC, is in effect.

In CV mode, an OR gate diode (D652) conducts and the CV loop regulates the output voltage. A CV error amplifier (P/O U621) compares the programmed voltage signal CVPROG to VMON which is the output signal from the V\_DIF amplifier (P/O U621). The range of VMON is 0 volts to +10 volts which corresponds to the zero-to-full-scale output voltage of the supply. If the output voltage exceeds the programmed voltage the OR GATE signal goes low causing the output voltage to decrease to the programmed value.

Conversely, if the output voltage is less than the programmed voltage, the OR GATE signal goes high causing the output voltage to increase to the programmed value. An externally applied dc signal, VPROG, can be used to program the output voltage. A 0 volt to -5 volt VP level produces a proportional zero-to-full-scale output voltage.

In CC mode, an OR gate diode (D651) conducts and the CC loop regulates the output voltage. A CC error amplifier (P/O U620) compares the programmed voltage signal CCPROG to IMON which is the output signal of 2nd I\_AMP (P/O U620). The range of IMON is 0 volts to +10 volts which corresponds to the zero-to-full-scale output voltage of the supply. If the output current exceeds the programmed current, the OR GATE signal goes low causing the output current to decrease to the programmed value.

Conversely, if the output current is less than the programmed current, the OR GATE signal goes high causing the output current to increase to the programmed value. An externally applied dc signal, IPROG, can be used to program the output current. A 0 volt to -5 volt IP level produces a proportional zero-to-full-scale output current.

Switching/Downprogramming Control (P/O A10) These circuits include a Ramp Generator, Divider /Deadtime Latch, Fast Sense Differential Amplifier, Pulse Width Modulator, Summing Comparator, Down-Programmer Control and OV Comparator circuits.

The Divider/Deadtime Latch (U600, U601, U602) divides the 2-MHz ALE\_CK signal from the Secondary  $\mu$ P and supplies 40 KHz pulses to the Ramp Generator (U607) and ON Latch (U604).

The OR-GATE signal (CV or CC control signal as previously described) is summed with the 40 KHz triangular waveform produced by the Ramp Generator. An input from the Fast Sense Differential Amplifier is also summed to compensate for a sudden transient in the rectified output.

The width of the output pulses from the Summing Amplifier vary as the OR-GATE control signal increases or decreases. These pulses are applied to the Pulse-Width Modulator (U603) via the On Latch. The PWM generates the square wave pulses that are applied to the A3 FET assembly to turn the FET switches on and off. The Deadtime Latch resets the ON Latch to provide a minimum off time for the FET switches.

The OV circuit compares the output voltage level with the OVREF signal which represents the programmed overvoltage level. When the output voltage exceeds the programmed OV value, the downprogrammer circuits are activated and the FET switches are turned off.

The Downprogrammer control circuit generates control signal DP CONTROL whenever an OV or disable condition has been detected, or when the output voltage exceeds the programmed value. DP CONTROL causes the downprogrammer FETs (Q980, Q981) on the A9 Downprogrammer/Fast Sense board to conduct and conduct current away from the load.

---

## A4 AC Input Board

The A4 Input Board contains the Inrush-Current Limit relay (K401), Main Power Relay (K402), current-limiting resistors (R407, R408) and open-fuse-detect resistor circuit (R400-R405). On power-on, the current-limit relay (K401) closes allowing the dc rail capacitors to charge under a controlled condition. This applies ac voltage to the A6 Bias Board. After the turn-on initialization period (approximately 10 seconds), the main relay (K402) closes, shorting out the current-limit resistor.

The open-fuse resistors supply partial ac voltage to the front panel LED board. An open-fuse causes an unbalanced voltage to be supplied to the open-fuse detect circuit causing the front panel **Check Fuses** LED to flash. If all three fuses are good, or if all three are open, the **Check Fuse** does not flash. The three-phase line inductor is connected to the A4 Input board via J417 (Range 1, 180-235Vac) or J418 (Range 2, 360-440Vac).

---

## A5 DC Rail Board

The A5 DC Rail board contains the full-wave, three-phase, rectifiers and the input filter circuits. The ac mains are full-wave rectified by D420-D425 and converted to two, 300-volt dc rails by filter capacitors, C423-C426, and by two range select connectors. In range 1 (180-235Vac), J438 connects the two DC rails, called Rail #1 and Rail #2, in parallel. Each rail supplies 300Vdc to the A3 FET board via J430 and J431. In Range 2 (360-440Vac), J439 connects the two DC rails in series. Each rail still supplies 300 Vdc to the A3 FET board via J430 and J431.

The A5 DC Rail board also contains the bias transformer and primary range select connectors J436 (Range 1) and J437 (Range 2). There are two LEDs (DS420, DS421) which light when more than 40Vdc is present on the dc rails.

---

**WARNING**

As a precaution always disconnect power supply from ac mains and wait 7 minutes before handling dc rail board. Be certain that the LEDs are completely extinguished.

---

The +24 auxiliary bias fuse, F420, and the standard bias fuse, F421, are located on the dc rail board.

---

## A3 FET Board

The A3 FET board consists of two power FET stages connected between the +rail and -rail voltages, and connected across the FET stages is a chassis mounted power transformer. The entire circuit represents an H-bridge configuration. A complete stage consists of eight, power FETs and two, bridge-driver ICs. The power FETs are mounted on but isolated from the heat sink assembly. The two power FET stages are isolated from each other.

The DRIVE1A, 1B and DRIVE2A, 2B pulses, received from the A10 Control board, are used by the bridge drivers (U201, U202, U301, U302) to derive control pulses for the FET switches. The width of the pulses determines the ON time of the FET switches, thereby determining the magnitude of the output voltage or current. DRIVE1A pulses turn on one set of +RAIL (Q301, Q311) and -RAIL (Q303, Q333) FETs, causing current to flow through power transformer, T900, in one direction. DRIVE2A pulses turn on the other set of +RAIL (Q304, Q344) and -RAIL (Q302, Q322) FETs causing current to flow through T900 in the opposite direction. The FET on/off periods are controlled by the duty-cycle detect and the peak-current detection circuits. If the output attempts to change, regulation is accomplished by the CV/CC control circuits on the A10 Control board. These circuits vary the width of the drive pulses and the duration of the FET on/off periods.

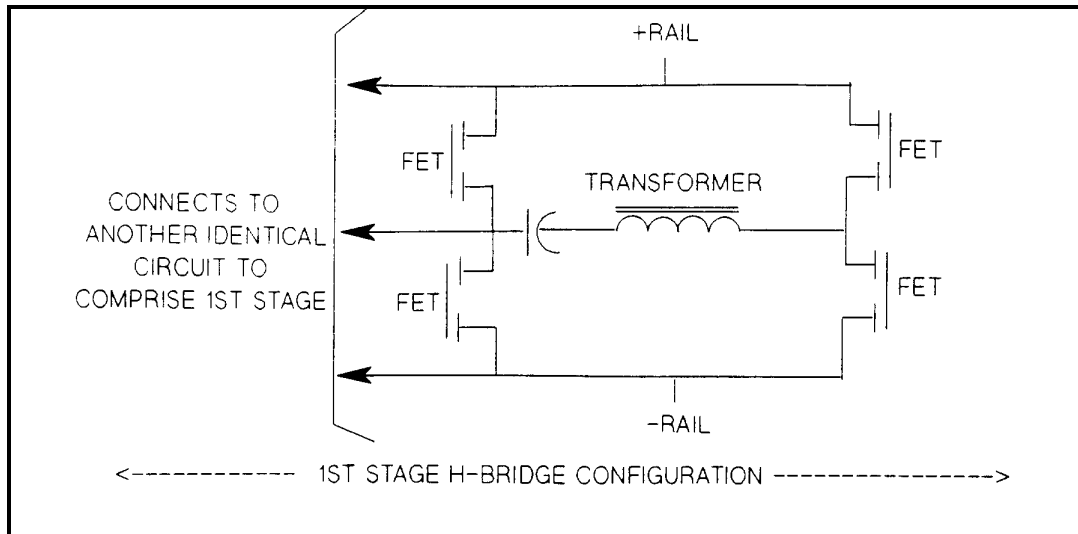

**Figure 4-2. 1ST Stage of the FET H-Bridge Configuration**

## Output Circuits

The output circuits include the following circuits:

- Chassis mounted components.
- Two power transformers, T900/T901.
- Two inductors, L900/L901.
- Four rectifiers, D900 through D903.
- Output capacitors.
- A7 Snubber board mounted to the heat sink.
- A8 Fast Sense board.
- A9 Slow/Downprogrammer board and output bus bars.

Each combination of power transformers, T900/T901, and rectifiers, D900/D903, couples the output pulses from the A3 FET board. The output of each transformer/rectifier combination is connected in parallel before being applied to the output filter. The output filter assembly consists of bus bars with the filter capacitors bolted to them. The filter chokes, L902 through L906, consist of ferrite cores enclosing the bus bar. The current-sense resistor, R900, is part of the positive-output bus bar.

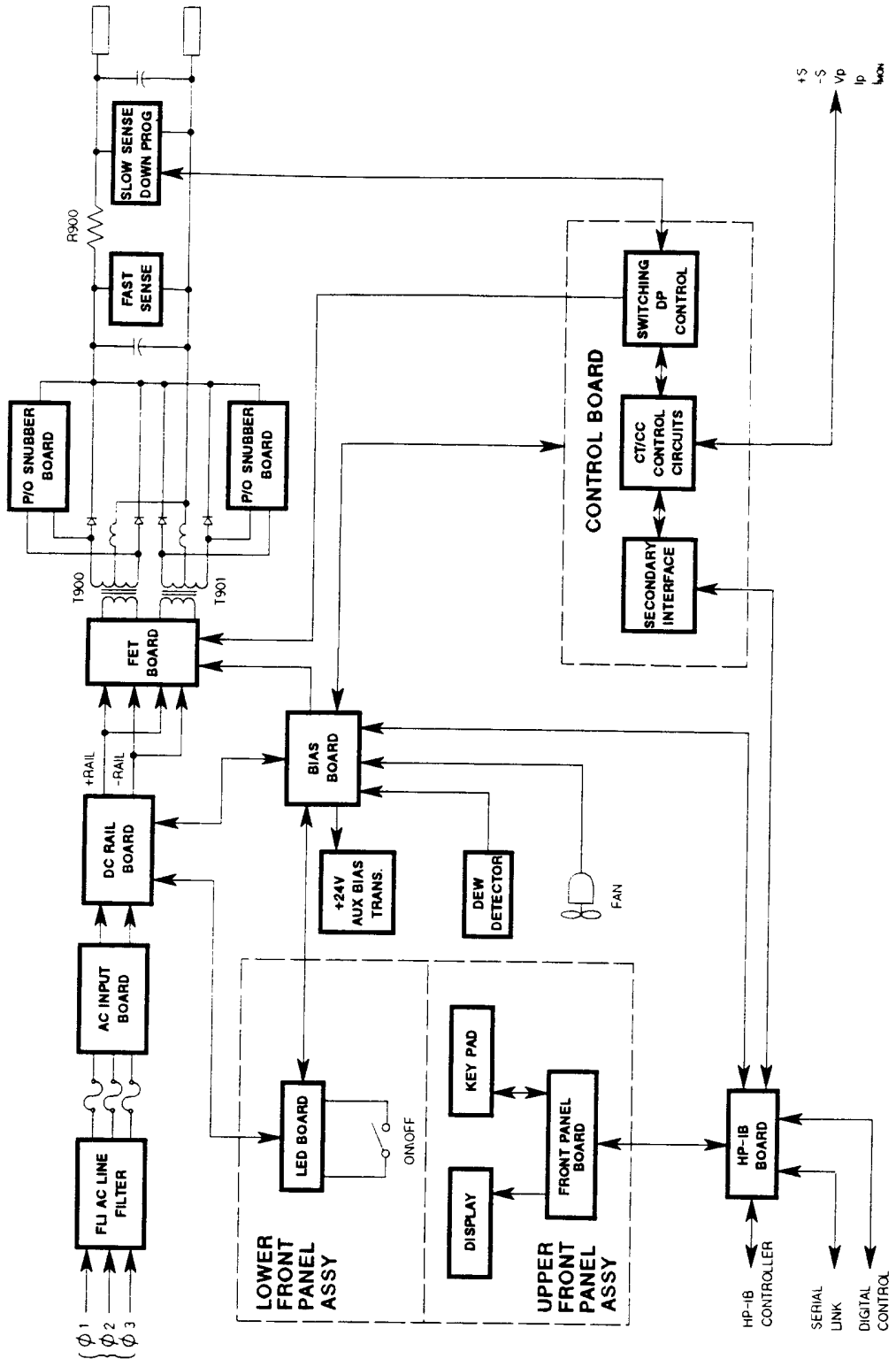

Figure 4-3. HP Series 668xA Power Supply, Block Diagram



# Replaceable Parts

## INTRODUCTION

### Chapter Organization

This section lists the replaceable electrical and mechanical parts for the HP 668xA series power supplies. (Component location diagrams are located in Chapter 6.) The lists consist of tables organized by assemblies as follows:

	Assembly	See
Main chassis *		Table 5-3
A1 Front Panel EBoard		Table 5-4
LED Board		Table 5-5
A2 HP-IB Board		Table 5-6
A3 FET Board		Table 5-7
A4 AC Input Board		Table 5-8
A5 DC Rail Board		Table 5-9
A6 Bias Board		Table 5-9
A7 Snubber Board		Table 5-11
A8 Fast Sense Board		Table 5-9
A9 Down Programming/Slow Sense Board		Table 5-9
A10 Control Board		Table 5-10
* The locations of circuit board assemblies and chassis-mounted components are shown in Fig 3-20.		

### Reading the Tables

Each table lists electrical components alphabetically by reference designator and provides the HP part number followed by the part description. Mechanical parts are placed after the electrical parts and listed alphabetically by part description. Unless otherwise specified, a listed part is used in all models of the series. Model-specific parts are tabulated by model number under the reference designator. The reference designators are defined in Table 5-1. Abbreviations used in parts descriptions are explained in Table 5-2.

**Table 5-1. Part Reference Designators**

A	assembly	J	jack	SW	switch
B	blower (fan)	K	relay	T	transformer
C	capacitor	L	inductor	TB	terminal block
CR	thyristor/SCR	P	plug	U	integrated circuit
D	diode	Q	transistor	VR	voltage regulator
DSP	display (LCD)	R	resistor	W	cable or jumper
F	fuse	RT	thermal resistor	Y	crystal oscillator

**Table 5-2. Part Description Abbreviations**

assy	assembly	M	metric	sq	square	w/o	without
bd	board	mch	machine	submin	subminiature	xfmr	transformer
blvl	belleville	mm	millimeter	thk	thick	xtal	crystal
gnd	ground	mtg	mounting	thrd	thread		
lg	long	PCB	pc board	w/	with		

## How To Order Parts

You can order parts from your local Hewlett-Packard Sales and Support Office (see the list of offices in the back of this manual). When ordering a part, please include the following information:

- the HP part number
- the part description
- the desired quantity
- the model number of the power supply (for example, HP 6682A)

**Table 5-3. Main Chassis, Replaceable Parts**

Ref. Desig.	HP Part No.	Description
<b>ASSEMBLIES &amp; SUBASSEMBLIES</b>		
A1	5060-3553 5060-3542	TESTED FRONT PANEL/KEYPAD TESTED KEYPAD PCB ASSY. LED Board
A2	5060-3591	TESTED HP-IB PC ASSY.
A3	5060-3540	TESTED FET ASSY.
A4	5060-3543	TESTED AC INPUT BOARD ASSY.
A5	5060-3544	TESTED DC RAIL BOARD ASSY.
A6	5060-3541	TESTED BIAS PC ASSY.
A7		
6680A	06680-60021	SNUBBER PCB ASSY.
6681A	06681-60021	SNUBBER PCB ASSY.
6682A	06682-60021	SNUBBER PCB ASSY.
6683A	06683-60021	SNUBBER PCB ASSY.
6684A	06684-60021	SNUBBER PCB ASSY.
A8		FAST SENSE PCB
A9		
6680A	06680-60022	DOWN PROGRAMMER / SLOW SENSE PC
6681A	06681-60022	DOWN PROGRAMMER / SLOW SENSE PC
6682A	06682-60022	DOWN PROGRAMMER / SLOW SENSE PC
6683A	06683-60022	DOWN PROGRAMMER / SLOW SENSE PC
6684A	06684-60022	DOWN PROGRAMMER / SLOW SENSE PC
A10		
6680A	06681-61020	TESTED CONTROL PCB ASSY.
6681A	06681-61020	TESTED CONTROL PCB ASSY.
6682A	06682-61020	TESTED CONTROL PCB ASSY.
6683A	06683-61020	TESTED CONTROL PCB ASSY.
6684A	06684-61020	TESTED CONTROL PCB ASSY.



**Table 5-3. Main Chassis, Replaceable Parts**

Ref. Desig.	HP Part No.	Description
<b>ELECTRICAL PARTS</b>		
C423	0180-4369	C-F 1500uF 400V
C424	0180-4369	C-F 1500uF 400V
C425	0180-4369	C-F 1500uF 400V
C426	0180-4369	C-F 1500uF 400V
C900		
6680A	0180-4516	CAP 33000uF 7.5V
6681A	0180-4532	CAP 22000uF 16V
6682A	0180-4615	CAP 18000uF 28V
6683A	not used	
6684A	not used	
C901		
6680A	0180-4516	CAP 33000uF 7.5V
6681A	0180-4532	CAP 22000uF 16V
6682A	0180-4615	CAP 18000uF 28V
6683A	0180-4596	CAP 13000uF 45V
6684A	0180-4597	CAP 7.200uF 55V
C902		
6680A	0180-4516	CAP 33000uF 7.5V
6681A	0180-4532	CAP 22000uF 16V
6682A	0180-4615	CAP 18000uF 28V
6683A	0180-4596	CAP 13000uF 45V
6684A	0180-4597	CAP 7.200uF 55V
C903		
6680A	0180-4516	CAP 33000uF 7.5V
6681A	0180-4532	CAP 22000uF 16V
6682A	0180-4615	CAP 18000uF 28V
6683A	0180-4596	CAP 13000uF 45V
6684A	0180-4597	CAP 7.200uF 55V
C904		
6680A	0180-4516	CAP 33000uF 7.5V
6681A	0180-4532	CAP 22000uF 16V
6682A	0180-4615	CAP 18000uF 28V
6683A	0180-4596	CAP 13000uF 45V
6684A	0180-4597	CAP 7.200uF 55V
C905		
6680A	0180-4516	CAP 33000uF 7.5V
6681A	0180-4532	CAP 22000uF 16V
6682A	0180-4615	CAP 18000uF 28V
6683A	0180-4596	CAP 13000uF 45V
6684A	0180-4597	CAP 7.200uF 55V

**Table 5-3. Main Chassis, Replaceable Parts (continued)**

Ref. Desig.	HP Part No.	Description
C906		
6680A	0180-4516	CAP 33000uF 7.5V
6681A	0180-4532	CAP 22000uF 16V
6682A	not used	
6683A	not used	
6684A	not used	
C907		
6680A	0180-4516	CAP 33000uF 7.5V
6681A	0180-4532	CAP 22000uF 16V
6682A	0180-4615	CAP 18000uF 28V
6683A	0180-4596	CAP 13000uF 45V
6684A	0180-4597	CAP 7.200uF 55V
C920		
6682A	0160-4183	CAP 1000pF 250V
6683A	0160-4183	CAP 1000pF 250V
6684A	0160-4183	CAP 1000pF 250V
C921		
6682A	0160-4183	CAP 1000pF 250V
6683A	0160-4183	CAP 1000pF 250V
6684A	0160-4183	CAP 1000pF 250V
C922		
6682A	0160-4183	CAP 1000pF 250V
6683A	0160-4183	CAP 1000pF 250V
6684A	0160-4183	CAP 1000pF 250V
C923		
6682A	0160-4183	CAP 1000pF 250V
6683A	0160-4183	CAP 1000pF 250V
6684A	0160-4183	CAP 1000pF 250V
C924		
6682A	0160-4183	CAP 1000pF 250V
6683A	0160-4183	CAP 1000pF 250V
6684A	0160-4183	CAP 1000pF 250V
C925		
6682A	0160-4183	CAP 1000pF 250V
6683A	0160-4183	CAP 1000pF 250V
6684A	0160-4183	CAP 1000pF 250V
D900		
6680A	1906-0396	SHOTTY RECTIFIER
6681A	1906-0396	SHOTTY RECTIFIER
D900A,B		
6682A	1906-0397	SHOTTY RECTIFIER
6683A	1906-0398	SHOTTY RECTIFIER
6684A	1906-0398	SHOTTY RECTIFIER
D901		
6680A	1906-0396	SHOTTY RECTIFIER
6681A	1906-0396	SHOTTY RECTIFIER
D901A,B		
6682A	1906-0397	SHOTTY RECTIFIER
6683A	1906-0398	SHOTTY RECTIFIER
6684A	1906-0398	SHOTTY RECTIFIER

**Table 5-3. Main Chassis, Replaceable Parts (continued)**

Ref. Desig.	HP Part No.	Description
D902		
6680A	1906-0396	SHOTTY RECTIFIER
6681A	1906-0396	SHOTTY RECTIFIER
D903		
6680A	1906-0396	SHOTTY RECTIFIER
6681A	1906-0396	SHOTTY RECTIFIER
L900		
6680A	06681-80001	CHOKE - OUTPUT
6681A	06681-80001	CHOKE - OUTPUT
6682A	06681-80004	CHOKE - OUTPUT
6683A	06681-80005	CHOKE - OUTPUT
6684A	06681-80006	CHOKE - OUTPUT
L901		
6680A	06681-80001	CHOKE- OUTPUT
6681A	06681-80001	CHOKE - OUTPUT
6682A	06681-80004	CHOKE - OUTPUT
6683A	06681-80005	CHOKE - OUTPUT
6684A	06681-80006	CHOKE- OUTPUT
L902	5080-2257	CORE
L903	5080-2257	CORE
L904	9170-1571	CORE
L905	9170-1571	CORE
L906	9170-1571	CORE
Q981	1855-0834	POWER MOSFET
Q982	1855-0834	POWER MOSFET
R900		
6680A	5080-2296	SHUNT-CURRENT
6681A	5080-2297	SHUNT-CURRENT
6682A	06682-80002	SHUNT-CURRENT
6683A	5080-2324	SHUNT-CURRENT
6684A	5080-2324	SHUNT-CURRENT
T900		
6680A	9100-5042	POWER TRANSFORMER
6681A	9100-5043	POWER TRANSFORMER
6682A	9100-5086	POWER TRANSFORMER
6683A	9100-5085	POWER TRANSFORMER
6684A	9100-5076	POWER TRANSFORMER
T901		
6680A	9100-5042	POWER TRANSFORMER
6681A	9100-5043	POWER TRANSFORMER
6682A	9100-5086	POWER TRANSFORMER
6683A	9100-5085	POWER TRANSFORMER
6684A	9100-5076	POWER TRANSFORMER

**Table 5-3. Main Chassis, Replaceable Parts (continued)**

Ref. Desig.	HP Part No.	Description
<b>MECHANICAL PARTS</b>		
	06652-00005	BUS BAR
	06680-20001	BUSS BAR BLOCK
	06680-20002	BUSS/FET BLOCK
	06680-80003	NAMEPLATE front panel model description
	06681-80003	NAMEPLATE front panel model description
	06682-80001	NAMEPLATE front panel model description
	06683-80001	NAMEPLATE front panel model description
	06684-80001	NAMEPLATE front panel model description
	0960-0882	SENSOR-MOISTURE
	1252-1488	TERM-BLK-4 POS
	1252-3698	CONNECTOR
	2110-0910	FUSE (see 5060-3513 )
	2110-0911	FUSE (see 5060-3512 )
	3160-0419	FAN FINGER GUARD
	3160-0571	FAN-TUBEAXIAL
	5001-0538	TRIM-SIDES
	5001-0539	TRIM SIDES,FRENCH GRAY
	5001-6776	CHASSIS, BASE
	5001-6778	PANEL, REAR
	5001-6779	COVER-OUTSIDE
	5001-6780	INPUT SUB-CHASSIS (see 5060-3490 )
	5001-6781	OUTPUT SUB-CHASSIS
	5001-6782	CHASSIS-TOP (inside cover )
	5001-6783	INPUT DECK
	5001-6784	OUTPUT DECK
	5001-6791	TRAY (control board )
	5001-6792	SHIELD
	5001-6793	HPIB-BRACKET (chassis top )
	5020-2783	HEATSINK-DIODE
	5020-2785	HEATSINK-FET
	5020-2797	SHIELD-ISOLATION
	5020-2808	INSULATOR
	5040-1688	BUSS-BEZEL
	5040-1689	BUSS BAR SUPPORT
	5040-1690	BRACKET-HS
	5040-1691	HS-PLEN
	5040-1694	BUSS BAR, PLUS, output end (large)
	5040-1696	BUSS BAR, PLUS, internal end (small)
	5040-1697	BLOCK-TOP COVER
	5040-1700	COLLAR-MOLDED
	5040-1701	BUSS BAR BRACE
	5041-880 1	FOOT
	5041-8819	CAP-STRAP HANDLE
	5041-8820	CAP-STRAP HANDLE
	5060-3237	AC INPUT COVER ASSY.
	5060-3490	AC SUB-CHASSIS ASSY.
	5060-3489	NEGATIVE OUTPUT BUSS BAR ASSY. w L902/L903 CORE

**Table 5-3. Main Chassis, Replaceable Parts (continued)**

Ref. Desig.	HP Part No.	Description
	5001-6780	SUB-CHASSIS
	5080-2262	3 PHASE LINE CHOKE
	5080-2298	CABLE - 3 phase line choke/AC input assy
	9100-5044	FAN TRANSFORMER
	5060-3492	WIRE KIT (+/- sense leads)
	5060-3512	400VAC/16A FUSE KIT
	2110-0911	3 ea. FUSE 16A 400VAC
	5060-3513	208VAC/30A FUSE KIT
	2110-0910	3 ea. FUSE 30A 500V
	5062-3705	STRAP HANDLE
	5080-2038	LABEL-WARNING (no operator serviceable)
	5080-2148	CABLE (chaining- 2 meters)
	5080-2168	CABLE-ASSY.
	5080-2277	SUL-THERMAL
	5080-2280	CABLE- BIAS/CONTROL
	5080-2282	CABLE - AC/RFI FILTER
	5080-2285	CABLE- HPIB/FAN
	1400-0611	CABLE CLAMP (HPIB/FAN)
	5080-2299	LABEL REAR PANEL
	5080-2413	CRATE ( shipping container )
	5080-2414	SKID ( shipping container )
	5080-2415	FOAM PAD ( shipping container )
	5080-2314	EDGE PROTECTOR 12 inches ( shipping container )
	5080-2315	EDGE PROTECTOR 2.5 inches ( shipping container )
	5080-2316	CABLE ASSY.
	5960-5588	MANUAL-OPERATING
	6681A#400	400V OPERATION
	6681A#601	BUS BAR COVER
	6681A#602	BUS BAR SPACER
	5060-3514	BB SPCR KIT #602
	6681A#861	CABLE-UL/CSA
	8120-6203	L CORD 10AWG300V
	6681A#862	CABLE-HARMONIZED
	8120-6204	L CORD 2.5mm450V
	6681A#908	RACK MOUNT KIT
	5062-3974	RACK MTG KIT
	5062-3977	RACK MOUNT KIT
	6681A#909	RACK MOUNT KIT W/HANDLES
	5062-3974	RACK MTG KIT
	5062-3983	RACK MOUNT KIT
	7120-6153	LABEL-WARNG
	9135-0493	FILTER-RFI

**Table 5-4. A1 Front Panel Board, Replaceable Parts**

Ref. Desig.	HP Part No.	Description
<b>ELECTRICAL PARTS</b>		
C1	0160-5422	Capacitor 0.047 $\mu$ F 20%
C2	0160-4808	Capacitor 470pF 5%
C4	0160-4787	Capacitor 22pF 5% 100V
C5	0180-0155	Capacitor 2.2 $\mu$ F 20V
C6,7	0160-5422	Capacitor 0.047 $\mu$ F 20%
C8	0160-4835	Capacitor 0.1 $\mu$ F 10% 50V
C10-12, C14-16	0160-5422	Capacitor 0.047 $\mu$ F 20%
C17	0180-0155	Capacitor 2.2 $\mu$ F 20V
D1,2	1906-0229	Diode array 50V
L1	9140-0158	COIL IUH 10%
J2	1251-4927	Receptacle LCD display
J3	1251-4926	Receptacle test header
J4,5	1252-0718	Receptacle (A3G1, A3G2)
J6	1251-8184	Receptacle phone (HP-IB board)
L1	9140-0158	Inductor 1 $\mu$ H 10%
R1	1810-0560	Resistor network DIP
R2	0698-3359	Resistor 12.7K 1%
R23-25,27-30	0698-3155	Resistor 4.64K 1%
R37	1810-0371	Resistor network SIP
R38	0698-3441	Resistor 215 $\Omega$ 1% 0.125W
R39,40	0698-3155	Resistor 4.64K 1%
RT1	0837-0412	Thermistor
S1	3101-3088	Line switch
VR16	1902-0950	Diode Zener 4.7V 5
U3	1820-6721	IC MPU
U4	5080-2466	ROM programmed front panel
U6	1818-4792	IC memory
U8	1820-2724	IC SN74ALS573BN
W3	1258-0209	Jumper (J3)
W5	0811-3590	Jumper
Y1	0410-2159	Crystal 10 MHz
Z16	1902-0950	Diode Zener 4.7V 5%
<b>MECHANICAL PARTS</b>		
--	1200-1274	Socket IC (U3)
--	1200-1417	Socket IC (U4)
--	0340-1277	Insulator (Y1)
--	0370-3238	KNOB Ref: RPG
--	0515-1455	SCREW - Ref: keypad PCB to front frame
--	0590-0534	NUT - SELFTREAD - Ref: Display & LED board to front panel
--	0960-0912	RPG - OPTICAL ENCODER
--	5063-3408	PCA (KEYPAD)

**Table 5-4. A1 Front Panel Board, Replaceable Parts (continued)**

Ref. Desig.	HP Part No.	Description
--	1000-0842	WINDOW Ref: 3 inches front frame
--	5001-6794	BLINDER Ref: 5 inches front frame
--	5040-1665	KEYPAD
--	5040-1687	FRONT FRAME - 88.1mm ( 3.5 inches )
--	5040-1698	FRONT FRAME - 132.6mm ( 5.25 inches )
--	5063-3473	LCD DISPLAY
--	5080-2245	LABEL Ref: 3.5 inches & 5 inches front frame
--	5080-2261	CABLE Ref: Keypad PCB to LCD display

**Table 5-5. Front Panel Board LED Assy, Replaceable Parts**

Ref. Desig.	HP Part No.	Description
<b>ELECTRICAL PARTS</b>		
C450	0180-4132	CAP 6.8uF 35V
C451	0160-4808	CAP 470pF 5%
D450	1901-1098	DIO-1N4150
D451	1901-1098	DIO-1N4150
D452	1901-1098	DIO-1N4150
D453	1901-1098	DIO-1N4150
R450	0698-3444	RES 316 1% .125W
R451	0757-0401	RES 100 1% .125W
R452	0698-3156	RES 14.7K 1%
R453	0698-8827	RES 1M 1% .125W
R454	0698-3156	RES 14.7K 1%
R455	0757-0280	RES 1K 1% .125W
U450	1858-0076	XSTR ARY 14P-DIP
U451	1858-0077	XSTR ARY 14P DIP
Z450	1902-0562	DIO-ZNR 22.1V 5%
<b>MECHANICAL PARTS</b>		
	5080-2281	CABLE LINE SWITCH Ref: E456=E457 to S1
	5080-2283	CABLE LED AC INPUT
	5080-2286	Ref: E450-E451 to DC RAIL J440 CABLE DEW/S1 CONNECTION Ref: E452-E455 to DC RAIL J441

**Table 5-6. A2 HP-IB Board, Replaceable Parts**

Ref. Desig.	HP Part No.	Description
<b>ELECTRICAL PARTS</b>		
C102	0160-4822	CAP 1000pF 5%
C103	0160-4822	CAP 1000pF 5%
C104	0160-4822	CAP 1000pF 5%
C105	0160-4822	CAP 1000pF 5%
C106	0180-0155	C-F 2.2uF 20V
C107	0160-4787	C-F 22pF 5% 100V
C108	0160-4787	C-F 22pF 5% 100V
C109	0160-5422	CAP .047uF 20%
C110	0160-5422	CAP .047uF 20%
C111	0160-5422	CAP .047uF 20%
C114	0160-5422	CAP .047uF 20%
C115	0160-5422	CAP .047uF 20%
C121	0160-5422	CAP .047uF 20%
C122	0180-3325	CAP 4700uF 25V
C123	0160-4835	CAP .1uF 10% 50V
C124	0180-0228	C-F 22uF 15V
C125	0160-5422	CAP .047uF 20%
C126	0160-4807	CAP 33pF 5% 100V
C127	0160-4807	CAP 33pF 5% 100V
C128	0160-4281	CAP 2200pF 20%
C129	0160-5422	CAP .047uF 20%
C130	0160-5422	CAP .047uF 20%
C131	0160-5422	CAP .047uF 20%
C132	0160-5422	CAP .047uF 20%
C133	0160-5422	CAP .047uF 20%
C134	0160-5422	CAP .047uF 20%
C135	0180-0228	C-F 22uF 15V
C136	0160-4803	CAP 68pF 5% 100V
C138	0160-4832	CAP .01uF 10%
C138	0160-5422	CAP .047uF 20%
C139	0160-5422	CAP .047uF 20%
C140	0160-5422	CAP .047uF 20%
D107	1901-0731	DIO-PWR RECT
D108	1901-0731	DIO-PWR RECT
D109	1901-0731	DIO-PWR RECT
D110	1901-0731	DIO-PWR RECT
D111	1901-1098	DIO-1N4150
D112	1901-1098	DIO-1N4150
D113	1901-1098	DIO-1N4150
D114	1901-1098	DIO-1N4150
D115	1901-1080	DIO-1N5817
D116	1901-1080	DIO-1N5817
F101	2110-0699	FU-SUBMIN 5A
L101	9100-1610	COIL 150NH 20%
Q101	1853-0089	XSTR PNP 2N4917
R103	0757-0442	RES 10K 1% .125W
R104	0698-3155	RES 4.64K 1%



**Table 5-6. A2 HP-IB Board, Replaceable Parts (continued)**

Ref. Desig.	HP Part No.	Description
R105	0683-1065	RES 10M 5% .25W
R106	0698-4037	RES 46.4 1%
R107	0698-0082	RES 464 1% .125W
R108	0757-0401	RES 100 1%.125W
R109	0698-0082	RES 464 1% .125W
R111	0698-3155	RES 4.64K 1%
R114	0698-3155	RES 4.64K 1%
R115	0698-4037	RES 46.4 1%
R116	0698-4037	RES 46.4 1%
R117	0698-4037	RES 46.4 1%
R118	0757-0280	RES 1K 1% .125W
R119	0698-8827	RES 1M 1%.125W
R120	0698-3155	RES 4.64K 1%
R121	0698-3155	RES 4.64K 1%
R122	0698-3155	RES 4.64K 1%
R123	0698-0082	RES 464 1% .125W
R130	0698-3155	RES 4.64K 1%
R131	0698-3155	RES 4.64K 1%
R132	0698-3155	RES 4.64K 1%
R133	0698-3155	RES 4.64K 1%
R134	0683-1025	RES 1K 5% .25W
R135	0698-3155	RES 4.64K 1%
R136	0698-3155	RES 4.64K 1%
R137	0757-0401	RES 100 1% .125W
S101	1200-1274	SKT-IC-CHP-CARR
U101	1826-0468	IC MC3423P1
U106	5080-2303	PRGMD-ROM, HPIB
U108	1818-4111	IC MCM 6164C55
U109	1820-6789	IC-INTERFACE
U110	1990-0444	OPTO ISOLATOR
U111	1990-0444	OPTO ISOLATOR
U112	1820-3210	IC 68B50
U113	1990-0543	OPTO-ISOLATOR
U114	1821-1479	IC-MPU
U115	1LH4-0001	HP-IB XCVR CHIP
U116	1820-2724	IC SN74ALS573BN
U117	1820-2549	IC-8291A
U 118	1820-4185	IC-INTERFACE
U119	5080-2153	PRGMD-GAL, HPIB
U120	5080-2154	PRGMD-GAL, HPIB
U121	1826-0536	IC LM340AK-5
Y101	0410-2109	XTAL 12.000 MHz
Z101	1902-0766	DIO-ZNR 18.2V 5%
Z102	1902-0959	DIO-ZNR 11V 5%
Z103	1902-0049	DIO-ZNR 6.19V 5%
Z104	1902-0049	DIO-ZNR 6.19V 5%
Z119	1902-0766	DIO-ZNR 18.2V 5%
Z120	1902-0766	DIO-ZNR 18.2V 5%

**Table 5-6. A2 HP-IB Board, Replaceable Parts (continued)**

Ref. Desig.	HP Part No.	Description
<b>MECHANICAL PARTS</b>		
J101	1252-0268	HP-IB CONNECTOR
J106	1251-4926	CONNECTOR - TEST HEADER
J107	1251-7330	PHONE RECEPTABLE SERIAL DATA
J108	1251-7330	PHONE RECEPTABLE SERIAL DATA
J114	1251-7330	PHONE RECEPTABLE CONTROL BUS
J115	1251-7330	PHONE RECEPTABLE CONTROL BUS
	0340-1277	INSULATOR Ref: Y101
	0360-2312	TERMINAL BLOCK Ref: TB101
	0515-0642	SCREW Ref: U121
	0515-0911	SCREW M3x0.5 Ref: J101
	0535-0031	NUT W/LKWR Ref: J101
	1200-0567	SOCKET Ref: U106
	1200-0639	SOCKET Ref: U119, U120
	1200-1274	SOCKET Ref: U114
	1205-0758	HEAT SINK Ref: U121

**Table 5-7. A3 FET Assembly, Replaceable Parts**

Ref. Desig.	HP Part No.	Description
<b>ELECTRICAL PARTS</b>		
C201	0160-7505	7uF+ - 5% 200V
C202	0180-4132	CAP 6.8uF 35V
C203	0160-4835	CAP .1uF 10% 50V
C204	0160-5098	CAP .22uF 10%
C205	0160-5098	CAP .22uF 10%
C206	0180-4132	CAP 6.8uF 35V
C207	0160-2006	CAP 100pF 10%
C208	0160-2006	CAP 100pF 10%
C209	0160-2006	CAP 100pF 10%
C210	0160-6838	CAP 2200pF 1KV
C211	0160-6838	CAP 2200pF 1KV
C213	0160-6838	CAP 2200pF 1KV
C214	0160-6838	CAP 2200pF 1KV
C215	0160-2006	CAP 100pF 10%
C216	0160-2006	CAP 100pF 10%
C217	0160-5098	CAP .22uF 10%
C218	0160-4835	CAP .1uF 10% 50V
C219	0160-2006	CAP 100pF 10%
C220	0180-4132	CAP 6.8uF 35V
C221	0160-5098	CAP .22uF 10%
C222	0180-4132	CAP 6.8uF 35V
C226	0160-4791	CAP 10pF 5% 100V
C227	0160-4835	CAP .1uF 10% 50V
C228	0160-2301	CAP 2000pF 100V
C229	0160-4918	CAP .022uF 50V

**Table 5-7. A3 FET Assembly, Replaceable Parts (continued)**

Ref. Desig.	HP Part No.	Description
C230	0160-4831	CAP 4700pF 10%
C231	0160-2301	CAP 2000pF 100V
C235	0160-4832	CAP .01uF 10%
C236	0160-4832	CAP .01uF 10%
C237	0160-4832	CAP .01uF 10%
C238	0160-4832	CAP .01uF 10%
C239	0160-4791	CAP 10pF 5% 100V
C240	0160-4832	CAP .01uF 10%
C242	0160-5098	CAP .22uF 10%
C243	0160-5098	CAP .22uF 10%
C244	0160-6806	CAP .1uF 400V
C245	0160-6806	CAP .1uF 400V
C248	0160-4832	CAP .01uF 10%
C258	0180-4132	CAP 6.8uF 35V
C301	0160-7505	7uF+ - 5% 200V
C302	0180-4132	CAP 6.8uF 35V
C303	0160-4835	CAP .1uF 10% 50V
C304	0160-5098	CAP .22uF 10%
C305	0160-5098	CAP .22uF 10%
C306	0180-4132	CAP 6.8uF 35V
C307	0160-2006	CAP 100pF 10%
C308	0160-2006	CAP 100pF 10%
C309	0160-2006	CAP 100pF 10%
C310	0160-6838	CAP 2200pF 1KV
C311	0160-6838	CAP 2200pF 1KV
C313	0160-6838	CAP 2200pF 1KV
C314	0160-6838	CAP 2200pF 1KV
C315	0160-2006	CAP 100pF 10%
C316	0160-2006	CAP 100pF 10%
C316	0160-2006	CAP 100pF 10%
C317	0160-5098	CAP .22uF 10%
C318	0160-4835	CAP .1uF 10% 50V
C319	0160-2006	CAP 100pF 10%
C320	0180-4132	CAP 6.8uF 35V
C321	0160-5098	CAP .22uF 10%
C322	0180-4132	CAP 6.8uF 35V
C326	0160-4791	CAP 10pF 5% 100V
C329	0160-5098	CAP .22uF 10%
C330	0160-4832	CAP .01uF 10%
C331	0160-4835	CAP .1uF 10% 50V
C335	0160-4832	CAP .01uF 10%
C336	0160-4832	CAP .01uF 10%
C337	0160-4832	CAP .01uF 10%
C338	0160-4832	CAP 01uF 10%
C339	0160-4791	CAP 10pF 5% 100V
C340	0160-4832	CAP .01uF 10%
C342	0160-5098	CAP .22uF 10%
C343	0160-5098	CAP .22uF 10%
C344	0160-6806	CAP .1uF 400V

**Table 5-7. A3 FET Assembly, Replaceable Parts (continued)**

Ref. Desig.	HP Part No.	Description
-------------	-------------	-------------

C345	0160-6806	CAP .1uF 400V
C346	0160-4800	CAP 120pF 5%
D201	1901-0050	DIO-SWITCHING
D202	1901-0050	DIO-SWITCHING
D202	1901-1065	DIO-IN4936 PWR
D203	1901-0050	DIO-SWITCHING
D204	1901-0050	DIO-SWITCHING
D205	1901-1065	DIO-IN4936 PWR
D206	1901-0050	DIO-SWITCHING
D207	1901-0050	DIO-SWITCHING
D208	1901-0050	DIO-SWITCHING
D209	1901-0050	DIO-SWITCHING
D210	1901-0050	DIO-SWITCHING
D213	1901-0050	DIO-SWITCHING
D214	1901-0050	DIO-SWITCHING
D215	1901-0050	DIO-SWITCHING
D216	1901-0050	DIO-SWITCHING
D217	1901-0050	DIO-SWITCHING
D220	1901-0050	DIO-SWITCHING
D221	1901-0050	DIO-SWITCHING
D222	1901-0050	DIO-SWITCHING
D223	1901-0050	DIO-SWITCHING
D224	1901-0731	DIO-PWR RECT
D301	1901-0050	DIO-SWITCHING
D302	1901-0050	DIO-SWITCHING
D302	1901-1065	DIO-IN4936 PWR
D303	1901-0050	DIO-SWITCHING
D304	1901-0050	DIO-SWITCHING
D305	1901-1065	DIO-IN4936 PWR
D306	1901-0050	DIO-SWITCHING
D307	1901-0050	DIO-SWITCHING
D308	1901-0050	DIO-SWITCHING
D309	1901-0050	DIO-SWITCHING
D310	1901-0050	DIO-SWITCHING
D313	1901-0050	DIO-SWITCHING
D314	1901-0050	DIO-SWITCHING
D315	1901-0050	DIO-SWITCHING
D316	1901-0050	DIO-SWITCHING
D317	1901-0050	DIO-SWITCHING
D320	1901-0050	DIO-SWITCHING
D321	1901-0050	DIO-SWITCHING
D322	1901-0050	DIO-SWITCHING
D323	1901-0050	DIO-SWITCHING
D324	1901-0731	DIO-PWR RECT
L201	9170-1454	CORE-SHLD-BEAD
L202	9170-1454	CORE-SHLD-BEAD
L203	9170-1454	CORE-SHLD-BEAD
L204	9170-1454	CORE-SHLD-BEAD
L205	9170-1510	CORE-MAGNETIC

**Table 5-7. A3 FET Assembly, Replaceable Parts (continued)**

Ref. Desig.	HP Part No.	Description
L206	9170-1510	CORE-MAGNETIC

L207	9170-1510	CORE-MAGNETIC
L208	9170-1510	CORE-MAGNETIC
L209	9170-1510	CORE-MAGNETIC
L210	9170-1510	CORE-MAGNETIC
L211	9170-1510	CORE-MAGNETIC
L212	9170-1510	CORE-MAGNETIC
L213	9170-1454	CORE-SHLD-BEAD
L214	9170-1454	CORE-SHLD-BEAD
L215	9170-1454	CORE-SHLD-BEAD
L216	9170-1454	CORE-SHLD-BEAD
L301	9170-1454	CORE-SHLD-BEAD
L302	9170-1454	CORE-SHLD-BEAD
L303	9170-1454	CORE-SHLD-BEAD
L304	9170-1454	CORE-SHLD-BEAD
L305	9170-1510	CORE-MAGNETIC
L306	9170-1510	CORE-MAGNETIC
L307	9170-1510	CORE-MAGNETIC
L308	9170-1510	CORE-MAGNETIC
L309	9170-1510	CORE-MAGNETIC
L310	9170-1510	CORE-MAGNETIC
L311	9170-1510	CORE-MAGNETIC
L312	9170-1510	CORE-MAGNETIC
L313	9170-1454	CORE-SHLD-BEAD
L314	9170-1454	CORE-SHLD-BEAD
L315	9170-1454	CORE-SHLD-BEAD
L316	9170-1454	CORE-SHLD-BEAD
Q201	1855-0859	MOSFET 500V 20A
Q202	1855-0859	MOSFET 500V 20A
Q203	1855-0859	MOSFET 500V 20A
Q204	1855-0859	MOSFET 500V 20A
Q211	1855-0859	MOSFET 500V 20A
Q222	1855-0859	MOSFET 500V 20A
Q233	1855-0859	MOSFET 500V 20A
Q244	1855-0859	MOSFET 500V 20A
Q251	1853-0363	D45H5/D45H8/363
Q252	1853-0363	D45H5/D45H8/363
Q253	1853-0363	D45H5/D45H8/363
Q254	1853-0363	D45H5/D45H8/363
Q301	1855-0859	MOSFET 500V 20A
Q302	1855-0859	MOSFET 500V 20A
Q303	1855-0859	MOSFET 500V 20A
Q304	1855-0859	MOSFET 500V 20A
Q311	1855-0859	MOSFET 500V 20A
Q322	1855-0859	MOSFET 500V 20A
Q333	1855-0859	MOSFET 500V 20A
Q344	1855-0859	MOSFET 500V 20A
Q351	1853-0363	D45H5/D45H8/363
Q352	1853-0363	D45H5/D45H8/363

**Table 5-7. A3 FET Assembly, Replaceable Parts**

Ref. Desig.	HP Part No.	Description
Q353	1853-0363	D45H5/D45H8/363
Q354	1853-0363	D45H5/D45H8/363

R201	0811-3903	RES 150 Ohm 5W NI
R202	0699-0208	RES 1 5% .25W CF
R203	0683-5615	RES 560 5% .25W
R205	0683-0625	RES 6.2 5% .25W
R206	0683-7505	RES 75 5% .25W
R207	0683-0335	RES 3.3 5% .25W
R208	0683-3305	RES 33 5% .25W
R209	0683-0625	RES 6.2 5% .25W
R210	0683-8205	RES 82 5% .25W
R211	0683-1535	RES 15K 5% .25W
R212	0683-1535	RES 15K 5% .25W
R213	0811-3903	RES 150 Ohm 5W NI
R214	0811-3903	RES 150 Ohm 5W NI
R216	0811-3903	RES 150 Ohm 5W NI
R217	0811-3903	RES 150 Ohm 5W NI
R220	0811-3903	RES 150 Ohm 5W NI
R221	0811-3903	RES 150 Ohm 5W NI
R222	0811-2556	RES 1.25 1% 4W
R224	0811-3903	RES 150 Ohm 5W NI
R225	0811-3903	RES 150 Ohm 5W NI
R226	0683-1535	RES 15K 5% .25W
R227	0698-3159	RES 26.1K 1%
R228	0683-8205	RES 82 5% .25W
R229	0683-0625	RES 6.2 5% .25W
R230	0683-3305	RES 33 5% .25W
R231	0683-7505	RES 75 5% 25W
R232	0683-0335	RES 3.3 5% 25W
R233	0683-0625	RES 6.2 5% 25W
R237	0757-0437	RES 4.75K 1%
R238	0757-0280	RES 1K 1% .125W
R239	0757-0437	RES 4.75K 1%
R240	0757-0280	RES 1K 1% .125W
R241	0757-0437	RES 4.75K 1%
R242	0757-0437	RES 4.75K 1%
R243	0683-1535	RES 15K 5% .25W
R244	0698-4457	RES 576 1% .125W
R245	0683-1015	RES 100 5% .25W
R246	0683-1555	RES 1.5M 5% .25W
R247	0757-0462	RES 75K 1%
R248	0698-3159	RES 26.1K 1%
R249	0757-0444	RES 13.1K 1%
R250	0698-3572	RES 60.4K 1%
R251	0757-0288	RES 9.09K 1%
R252	0698-3225	RES 1.43K 1%
R253	0698-6533	RES 12.5K 1%
R254	0698-3279	RES 4.99K 1%
R255	0683-1015	RES 100 5% .25W

**Table 5-7. A3 FET Assembly, Replaceable Parts (continued)**

Ref. Desig.	HP Part No.	Description
R256	0698-3432	RES 26.1 1%
R257	0698-3430	RES 21.5 1%
R258	0683-1035	RES 10K 5% .25W

R260	0683-8205	RES 82 5% .25W
R261	0683-8205	RES 82 5% .25W
R262	0683-1215	RES 120 5% .25W
R263	0683-8205	RES 82 5% .25W
R264	0683-8205	RES 82 5% .25W
R265	0683-8205	RES 82 5% .25W
R266	0683-1215	RES 120 5% .25W
R267	0683-8205	RES 82 5% .25W
R268	0698-3572	RES 60.4K 1%
R269	0698-4121	RES 11.3K 1%
R270	0757-0440	RES 7.5K 1%
R271	0757-0200	RES 5.62K 1%
R272	0757-0442	RES 10K 1% .125W
R273	0757-0437	RES 4.75K 1%
R274	0757-0437	RES 4.75K 1%
R275	0757-0437	RES 4.75K 1%
R277	0698-3633	RES 3905% 2W MO
R301	0811-3903	RES 150Ohm 5W NI
R302	0699-0208	RES 1 5% .25W CF
R303	0683-5615	RES 5605% .25W
R304	0698-4435	RES 2.49K 1%
R305	0683-0625	RES 6.25% .25W
R306	0683-7505	RES 75 5% .25W
R307	0683-0335	RES 3.3 5% .25W
R308	0683-3305	RES 33 5% .25W
R309	0683-0625	RES 6.2 5% .25W
R310	0683-8205	RES 82 5% .25W
R311	0683-1535	RES 15K 5% .25W
R312	0683-1535	RES 15K 5% .25W
R313	0811-3903	RES 150 Ohm 5W NI
R314	0811-3903	RES 150 Ohm 5W NI
R316	0811-3903	RES 150 Ohm 5W NI
R317	0811-3903	RES 150 Ohm 5W NI
R320	0811-3903	RES 150 Ohm 5W NI
R321	0811-3903	RES 150 Ohm 5W NI
R322	0811-2556	RES 1.25 1% 4W
R324	0811-3903	RES 150 Ohm 5W NI
R325	0811-3903	RES 150 Ohm 5W NI
R326	0683-1535	RES 15K 5% .25W
R327	0683-1555	RES 1.5M 5% .25W
R328	0683-8205	RES 82 5% .25W
R329	0683-0625	RES 6.2 5% .25W
R330	0683-3305	RES 33 5% .25W
R331	0683-7505	RES 75 5% .25W
R332	0683-0335	RES 3.3 5% .25W
R333	0683-0625	RES 6.2 5% .25W

**Table 5-7. A3 FET Assembly, Replaceable Parts (continued)**

<b>Ref. Desig.</b>	<b>HP Part No.</b>	<b>Description</b>
R337	0757-0437	RES 4.75K 1%
R338	C757-0280	RES 1K 1% .125W
R339	0757-0437	RES 4.75K 1%
R340	0757-0280	RES 1K 1% .125W

R341	0757-0437	RES 4.75K 1%
R342	0757-0437	RES 4.75K 1%
R343	0683-1535	RES 15K 5% .25W
R354	0757-0442	RES 10K 1% .125W
R355	0698-3136	RES 17.8K 1%
R356	0757-0382	RES 16.21%
R357	0757-0382	RES 16 2 1%
R360	0683-8205	RES 82 5% .25W
R361	0683-8205	RES 82 5% .25W
R362	0683-1215	RES 120 5% .25W
R363	0683-8205	RES 82 5% .25W
R364	0683-8205	RES 82 5% .25W
R365	0683-8205	RES 82 5% .25W
R366	0683-1215	RES 120 5% .25W
R367	0683-8205	RES 82 5% .25W
R368	0698-3572	RES 60.4K 1%
R369	0698-4121	RES 11.3K 1%
R370	0757-0440	RES 7.5K 1%
R371	0757-0200	RES 5.62K 1%
R372	0757-0442	RES 10K 1% .125W
R373	0757-0437	RES 4.75K 1%
R374	0757-0437	RES 4 75K 1%
R375	0757-0437	RES 4.75K 1%
R377	0698-3633	RES 390 5% 2W MO
R378	0757-0274	RES 1.21K 1%
R379	0683-1005	RES 10 5% .25W
R380	0757-0437	RES 4.75K 1%
R381	0698-0085	RES 2.61K 1%
R382	0683-1015	RES 100 5% .25W
R383	0757-0442	RES 10K 1% .125W
R384	8159-0005	RES-ZERO OHMS
R385	8159-0005	RES-ZERO OHMS
T202	9100-4350	XFMR-CURRENT
T204	06624-80091	XFMR-PULSE
T205	5080-2238	XFMR-CUR SHARING
T302	9100-4350	XFMR-CURRENT
T304	06624-80091	XFMR-PULSE
U201	1820-8433	PWM I.C. IR2110
U202	1820-8433	PWM I.C. IR2110
U203	1826-1343	IC-VOLTAGE REG TL431CP
U204	1826-0138	IC COMPARATOR LM339N
U205	1826-1475	VOLTAGE COMPTR LT1011CN8
U301	1820-8433	PWM I.C. IR2110
U302	1820-8433	PWM I.C. IR2110
U303	1826-1343	IC-VOLTAGE REG TL431CP

**Table 5-7. A3 FET Assembly, Replaceable Parts (continued)**

Ref. Desig.	HP Part No.	Description
U304	1826-0412	IC LM393N
U305	1990-0996	OPTO-ISOLATOR HCPL-2200
Z201	1902-1377	DIO-ZNR 6 19V
Z301	1902-1377	DIO-ZNR 6.19V
MECHANICAL PARTS		



	5080-2279	CABLE FET CONTROL Ref: E208-E209 to CONTROL J511
	5080-2283	CABLE +15V BIAS Ref: E206-E207 to BIAS J831 Ref: E306-E307 to BIAS J830
	5080-2291	CABLE FET RAIL A Ref: E201-E202 to DCRAIL J430
	5080-2295	CABLE FET RAIL B Ref: E301-E302 to DCRAIL J431

**Table 5-8. A4 AC Input Assembly, Replaceable Parts**

Ref. Desig.	HP Part No.	Description
<b>ELECTRICAL PARTS</b>		
C420	0160-7606	CAP 1uF 275V
C428	0160-7898	CAP 0.01uF 440V
C429	0160-7898	CAP 0.01uF 440V
C430	0160-7898	CAP 0.01uF 440V
J417	1251-5422	CONNECTOR
J418	1251-5422	CONNECTOR
J419	1251-6832	CONNECTOR
J420	1251-3819	CONNECTOR
K401	0490-1908	RELAY 24V COIL
K402	5060-3593	CONTACTOR, 3 POLE
R400	0764-0027	RES 75K 5% 2W MO
R401	0764-0027	RES 75K 5% 2W MO
R402	0764-0027	RES 75K 5% 2W MO
R403	0764-0027	RES 75K 5% 2W MO
R404	0764-0027	RES 75K 5% 2W MO
R405	0764-0027	RES 75K 5% 2W MO
R407	0699-3191	RES 27 OHM 5% 20W
R408	0699-3191	RES 27 OHM 5% 20W
R435	0698-3609	RES 22 OHM 5% 2W
R436	0698-3609	RES 22 OHM 5% 2W
R437	0698-3609	RES 22 OHM 5% 2W
<b>MECHANICAL PARTS</b>		
	5060-3493	WIRE KIT Ref: E403-E408 to F1,F2,F3
	5080-2284	CABLE RELAY CONTROL Ref: E411-E413 to BIAS J827

**Table 5-9. A5 DC Rail Assembly, Replaceable Parts**

Ref. Desig.	HP Part No.	Description
<b>ELECTRICAL PARTS</b>		
C418	0160-4048	CAP 0.022uF 20%
C420	0160-7606	CAP 1uF 275V
C421	0160-7606	CAP 1uF 275V
C422	0160-7606	CAP 1uF 275V
C427	0160-7743	C-F .047uF 380V
D420	5060-3516	ASSY.-RECTIFIER
D421	5060-3516	ASSY.-RECTIFIER
D422	5060-3516	ASSY.-RECTIFIER
D423	5060-3516	ASSY.-RECTIFIER
D424	5060-3516	ASSY.-RECTIFIER
D425	5060-3516	ASSY.-RECTIFIER
DS420	1990-0517	LED
DS421	1990-0517	LED
F420	2110-1107	FUSE CLIPS
F420	2110-0934	FUSE .5A, 500V
F421	2110-1107	FUSE CLIPS
F421	2110-0934	FUSE .5A, 500V
J430	1251-7616	CONNECTOR
J431	1251-7616	CONNECTOR
J432	1251-6832	CONNECTOR
J433	1251-3819	CONNECTOR
J436	1251-3837	CONNECTOR
J437	1251-3837	CONNECTOR
J438	1251-3837	CONNECTOR
J439	1251-3837	CONNECTOR
J440	1252-0055	CONNECTOR
J441	1252-0056	CONNECTOR
L420	5080-2300	INDUCTOR-NM
L421	5080-2300	INDUCTOR-NM
R420	0698-3611	RES 27 5% 2W MO
R421	0698-3611	RES 27 5% 2W MO
R422	0698-3611	RES 27 5% 2W MO
R423	0764-0044	RES 8.2K 5% 2W
R424	0764-0044	RES 8.2K 5% 2W
R425	0764-0044	RES 8.2K 5% 2W
R426	0764-0044	RES 8.2K 5% 2W
R427	0764-0044	RES 8.2K 5% 2W
R428	0764-0044	RES 8.2K 5% 2W
R429	0764-0044	RES 8.2K 5% 2W
R430	0764-0044	RES 8.2K 5% 2W
R431	0764-0044	RES 8.2K 5% 2W
R432	0764-0044	RES 8.2K 5% 2W
R433	0764-0044	RES 8.2K 5% 2W
R434	0764-0044	RES 8.2K 5% 2W

**Table 5-9. A5 DC Rail Assembly, Replaceable Parts (continued)**

Ref. Desig.	HP Part No.	Description
<b>MECHANICAL PARTS</b>		
	5080-2286	CABLE BIAS 24V SECONDARY Ref: E440-E443 to BIAS J816
	5080-2288	CABLE AC POWER Ref: E420-E425 to ACINPUT J420
	5080-2289	CABLE AC BIAS Ref: E430-E434 to ACINPUT J419
	5080-2293	CABLE BIAS LINE SELECT Ref: E444-E447 to J436/J437
	5080-2294	CABLE RAIL LINE SELECT Ref: E448-451 to J438/J439

**Table 5-10. A6 Bias Assembly, Replaceable Parts**

Ref. Desig.	HP Part No.	Description
<b>ELECTRICAL PARTS</b>		
C800	0160-4834	CAP .047uF 10%
C801	0180-4140	CAP 1800 uF 63V
C803	0160-5422	CAP .047uF 20%
C804	0180-4131	CAP 4.7uF 35V
C805	0160-7743	C-F .047uF 380V
C806	0160-4834	CAP .047uF 10%
C807	0180-3587	CAP 1000uF 50V
C808	0180-0230	C-F luF 50V
C809	0180-4129	CAP luF 35V
C810	0180-4129	CAP luF 35V
C811	0160-4834	CAP .047uF 10%
C812	0160-4834	CAP .047uF 10%
C813	0180-2980	C-F 1000uF 50V
C814	0180-4129	CAP luF 35V
C815	0180-4129	CAP luF 35V
C8 16	0180-4405	CAP 470 uF 50V
C817	0180-4405	CAP 470 uF 50V
C818	0180-0230	C-F luF 50V
C819	0180-0230	C-F luF 50V
C820	0180-4129	CAP luF 35V
C821	0180-4129	CAP luF 35V
C822	0180-4129	CAP luF 35V
C823	0180-4131	CAP 4.7uF 35V
C824	0180-3298	C-F 2200uF 50V
C825	0180-3298	C-F 2200uF 50V
C826	0160-4834	CAP .047uF 10%
C827	0180-3587	CAP 1000uF 50V
C828	0180-0230	C-F luF 50V
C829	0180-4129	CAP luF 35V
C830	0180-4129	CAP luF 35V

**Table 5-10. A6 Bias Assembly, Replaceable Parts (continued)**

Ref. Desig.	HP Part No.	Description
C831	0180-4129	CAP 1uF 35V
C841	0180-4397	C-F 100uF 63V
C842	0180-4131	CAP 4.7uF 35V
C843	0160-4835	CAP .1uF 10% 50V
C844	0160-4835	CAP .1uF 10% 50V
C845	0160-4835	CAP .1uF 10% 50V
C846	0180-4131	CAP 4.7uF 35V
C847	0180-0228	C-F 22uF 15V
D800	1901-0731	DIO-PWR RECT
D801	1901-0731	DIO-PWR RECT
D802	1901-0731	DIO-PWR RECT
D803	1901-0731	DIO-PWR RECT
D804	1901-0731	DIO-PWR RECT
D805	1901-0731	DIO-PWR RECT
D806	1901-0731	DIO-PWR RECT
D807	1901-0731	DIO-PWR RECT
D808	1901-0731	DIO-PWR RECT
D809	1901-0731	DIO-PWR RECT
D810	1901-0731	DIO-PWR RECT
D811	1901-0731	DIO-PWR RECT
D812	1901-0731	DIO-PWR RECT
D813	1901-0731	DIO-PWR RECT
D814	1901-0731	DIO-PWR RECT
D815	1901-0731	DIO-PWR RECT
D816	1901-0731	DIO-PWR RECT
D817	1901-0731	DIO-PWR RECT
D818	1901-0731	DIO-PWR RECT
D819	1901-0731	DIO-PWR RECT
D820	1902-0018	DIO-ZNR 1N941
D830	1901-1098	DIO-1N4150
D832	1902-3393	DIO-ZNR 75V 55°
F800	2110-0712	FU-SUBMIN 4A
F803	2110-0679	FUSE 1.5A 125V
F804	2110-0679	FUSE 1.5A 125V
F805	2110-0679	FUSE 1.5A 125V
F806	2110-0679	FUSE 1.5A 125V
J801	1252-1670	CONNECTOR
J809	1252-8837	CONNECTOR
J816	1252-0056	CONNECTOR
J821	1252-5230	CONNECTOR
J827	1251-7070	CONNECTOR
J830	1252-0055	CONNECTOR
J831	1252-0055	CONNECTOR
Q818	5060-3245	HEAT SINK-TRANSISTOR (1854-0828) ASSY.
Q819	5060-3245	HEAT SINK-TRANSISTOR (1854-0828) ASSY.
Q820	5060-3527	HEAT SINK-TRANSISTOR (1854-0828) ASSY.
Q821	5060-3527	HEAT SINK-TRANSISTOR (1854-0828) ASSY.
Q822	5060-3527	HEAT SINK-TRANSISTOR (1854-0828) ASSY.
R800	0683-3025	RES 3K 5% .25W

**Table 5-10. A6 Bias Assembly, Replaceable Parts (continued)**

Ref. Desig.	HP Part No.	Description
R801	0683-0475	RES 4.7 5% .25W
R802	0683-0475	RES 4.7 5% .25W
R803	0698-0084	RES 2.15K 1%
R804	0698-3440	RES 196 1% .125W
R805	8159-0005	RES-ZERO OHMS
R806	8159-0005	RES-ZERO OHMS
R807	0698-0084	RES 2.15K 1%
R808	0698-0084	RES 2.15K 1%
R809	0698-3440	RES 196 1% .125W
R810	0698-3440	RES 196 1% .125W
R811	0699-0208	RES 1 5% .25W CF
R812	8159-0005	RES-ZERO OHMS
R813	8159-0005	RES-ZERO OHMS
R814	8159-0005	RES-ZERO OHMS
R815	8159-0005	RES-ZERO OHMS
R816	8159-0005	RES-ZERO OHMS
R817	0757-0442	RES 10K 1% .125W
R818	0698-6392	RES 22K .1%.125W
R819	0698-6631	RES 2.5K .1%
R820	0699-0070	RES 3.16M 1%
R821	0698-4493	RES 34K 1% .125W
R822	0757-0290	RES 6.19K 1%
R823	0757-0283	RES 2K 1% .125W
R824	0699-0070	RES 3.16M 1%
R825	0757-0444	RES 12.1K 1%
R827	0757-0274	RES 1.21K 1%
R828	0757-0444	RES 12.1K 1%
R831	0757-0290	RES 6.19K 1%
R833	0757-0280	RES 1K 1% .125W
R834	0757-0442	RES 10K 1% .125W
R835	0698-0085	RES 2.61K 1%
R836	0757-0442	RES 10K 1% .125W
R841	0698-6363	RES 40K .1%
R842	0698-6360	RES 10K .1%
R843	0757-0472	RES 200K 1%
R844	0698-6977	RES 30K .1% .125
R845	0698-6360	RES 10K .1%
R847	0698-6360	RES 10K .1%
R848	0698-6977	RES 30K .1% .125
R849	0683-3325	RES 3.3K 5% .25W
R850	0698-6977	RES 30K .1% .125
R851	0698-4037	RES 46.4 1%
R852	0683-3325	RES 3.3K 5% .25W
R853	0683-1005	RES 10 5% .25W
R854	0683-1005	RES 10 5% .25W
R855	0683-1005	RES 10 5% .25W
R856	0698-3152	RES 3.48K 1%
R857	0698-4037	RES 46.4 1%
R858	0683-1005	RES 10 5% .25W

**Table 5-10. A6 Bias Assembly, Replaceable Parts (continued)**

Ref. Desig.	HP Part No.	Description
-------------	-------------	-------------

R859	0683-1005	RES 10 5% .25W
R860	0683-1005	RES 10 5% .25W
R861	0698-8234	RES 12.1K 1%
R862	0699-0070	RES 3.16M 1%
R863	0757-0469	RES 150K 1%
R864	0699-0070	RES 3.16M 1%
R865	0757-0464	RES 90.9K 1%
R867	0757-0290	RES 6.19K 1%
R868	0757-0199	RES 21.5K 1%
R869	0757-0281	RES 2.74K 1%
R870	8159-0005	RES-ZERO OHMS
R871	0698-3440	RES 196 1% .125W
R872	0698-0084	RES 2.15K 1%
R873	8159-0005	RES-ZERO OHMS
R874	0757-0274	RES 1.21K 1%
R875	0698-4037	RES 46.4 1%
R876	0683-1005	RES 10 5% .25W
R877	0683-1005	RES 10 5% .25W
R878	0683-1005	RES 10 5% .25W
R879	8159-0005	RES-ZERO OHMS
R880	8159-0005	RES-ZERO OHMS
T801	9100-5040	XFMR-HPIB
T802	9100-5041	XFMR-BIAS
U801	5060-2942	HEAT SINK-LM317T REGULATOR ASSY.
U802	5060-2948	HEAT SINK-UA7805UC REGULATOR ASSY.
U803	5060-2942	HEAT SINK-LM317T REGULATOR ASSY.
U804	5060-2943	HEAT SINK-LM337T REGULATOR ASSY.
U805	5060-2942	HEAT SINK-LM317T REGULATOR ASSY.
U806	1826-0544	IC-V RGLTR 2.5V MC1403U
U807	1826-0138	IC COMPARATOR LM339N
U808	1858-0047	XSTR ARY 16P-DIP
U809	1990-1074	OPTO-ISOLATOR 4N35
U810	1990-1074	OPTO-ISOLATOR 4N35
U811	1990-1074	OPTO-ISOLATOR 4N35
U812	1826-0161	IC LM324N
U813	1990-1074	OPTO-ISOLATOR 4N35
<b>MECHANICAL PARTS</b>		
	5080-2292	CABLE PRIMARY BIAS Ref: E800-E804 to DCRAIL J432

**Table 5-11. A7 Snubber Assembly, Replaceable Parts**

Ref. Desig.	HP Part No.	Description
<b>ELECTRICAL PARTS</b>		
.C910		
6680A	0160-0162	CAP .022uF 10%
6681A	0160-0162	CAP .022uF 10%
6682A	0160-6896	CAP .015uF 10%
6683A	0160-4845	CAP 6800pF 10%
6684A	0160-6162	CAP 4700pF 10%
C911		
6680A	0160-0162	CAP .022uF 10%
6681A	0160-0162	CAP .022uF 10%
6682A	0160-6896	CAP .015uF 10%
6683A	0160-4845	CAP 6800pF 10%
6684A	0160-6162	CAP 4700pF 10%
C912		
6680A	0160-0162	CAP .022uF 10%
6681A	0160-0162	CAP .022uF 10%
6682A	0160-6896	CAP .015uF 10%
6683A	0160-4845	CAP 6800pF 10%
6684A	0160-6162	CAP 4700pF 10%
C913		
6680A	0160-0162	CAP .022uF 10%
6681A	0160-0162	CAP .022uF 10%
6682A	0160-6896	CAP .015uF 10%
6683A	0160-4845	CAP 6800pF 10%
6684A	0160-6162	CAP 4700pF 10%
R910		
6680A	0698-3601	RES 10 5% 2W MO
6681A	0698-3601	RES 10 5% 2W MO
6682A	0698-3611	RES 27 5% 2W MO
6683A	0764-0013	RES 56 5% 2W MO
6684A	0698-3614	RES 43 5% 2W MO
R911		
6680A	0698-3601	RES 10 5% 2W MO
6681A	0698-3601	RES 10 5% 2W MO
6682A	0698-3611	RES 27 5% 2W MO
6683A	0764-0013	RES 56 5% 2W MO
6684A	0698-3614	RES 43 5% 2W MO
R912		
6680A	0698-3601	RES 10 5% 2W MO
6681A	0698-3601	RES 10 5% 2W MO
6682A	0698-3611	RES 27 5% 2W MO
6683A	0764-0013	RES 56 5% 2W MO
6684A	0698-3614	RES 43 5% 2W MO

**Table 5-11. A7 Snubber Assembly, Replaceable Parts (continued)**

Ref. Desig.	HP Part No.	Description
R913		
6680A	0698-3601	RES 10 5% 2W MO
6681A	0698-3601	RES 10 5% 2W MO
6682A	0698-3611	RES 27 5% 2W MO
6683A	0764-0013	RES 56 5% 2W MO
6684A	0698-3614	RES 43 5% 2W MO
R914		
6680A	not used	
6681A	not used	
6682A	0698-3611	RES 27 5% 2W MO
6683A	0764-0013	RES 56 5% 2W MO
6684A	0698-3614	RES 43 5% 2W MO
R915		
6680A	not used	
6681A	not used	
6682A	0698-3611	RES 27 5% 2W MO
6683A	0764-0013	RES 56 5% 2W MO
6684A	0698-3614	RES 43 5% 2W MO
R916		
6680A	not used	
6681A	not used	
6682A	0698-3611	RES 27 5% 2W MO
6683A	0764-0013	RES 56 5% 2W MO
6684A	0698-3614	RES 43 5% 2W MO
R917		
6680A	not used	
6681A	not used	
6682A	0698-3611	RES 27 5% 2W MO
6683A	0764-0013	RES 56 5% 2W MO
6684A	0698-3614	RES 43 5% 2W MO
R918		
6680A	not used	
6681A	not used	
6682A	0698-3611	RES 27 5% 2W MO
6683A	0764-0013	RES 56 5% 2W MO
6684A	0698-3614	RES 43 5% 2W MO
R919		
6680A	not used	
6681A	not used	
6682A	0698-3611	RES 27 5% 2W MO
6683A	0764-0013	RES 56 5% 2W MO
6684A	0698-3614	RES 43 5% 2W MO
R920		
6680A	not used	
6681A	not used	
6682A	0698-3611	RES 27 5% 2W MO
6683A	0764-0013	RES 56 5% 2W MO
6684A	0698-3614	RES 43 5% 2W MO

Table 5-11. A7 Snubber Assembly, Replaceable Parts (continued)



Ref. Desig.	HP Part No.	Description
R921		
6680A	not used	
6681A	not used	
6682A	0698-3611	RES 27 5% 2W MO
6683A	0764-0013	RES 56 5% 2W MO
6684A	0698-3614	RES 43 5% 2W MO
<b>MECHANICAL PARTS</b>		
6680A	5060-3327	WIRE KIT ( 2 required ) Ref: D900,D901,D902,D903
6681A	5060-3327	WIRE KIT ( 2 required ) Ref: D900,D901,D902,D903
6682A	5060-3565	WIRE KIT Ref: D900A,B,D901A,B
6683A	5060-3365	WIRE KIT Ref: D900A,B,D901A,B
6684A	5060-3365	WIRE KIT Ref: D900A,B,D901A,B

**Table 5-12. A7 Fast Sense Assembly, Replaceable Parts**

Ref. Desig.	HP Part No.	Description
<b>ELECTRICAL PARTS</b>		
	06680-60023	FAST SENSE PC ASSEMBLY Ref:6680A POWER SUPPLY
	06681-60023	FAST SENSE PC ASSEMBLY Ref:6681A POWER SUPPLY
	06682-60023	FAST SENSE PC ASSEMBLY Ref:6682A POWER SUPPLY
	06683-60023	FAST SENSE PC ASSEMBLY Ref:6683A POWER SUPPLY Ref:6681A POWER SUPPLY
	06684-60023	FAST SENSE PC ASSEMBLY Ref:6684A POWER SUPPLY
C1000	0160-5468	CAP 0.47uF 50V
<b>MECHANICAL PARTS</b>		
	5080-2287	CABLE Ref: EI001-EI003 to CONTROL J512

**Table 5-13. A9 Down Programmer/Slow Sense, Replaceable Parts**

Ref. Desig.	HP Part No.	Description
<b>ELECTRICAL PARTS</b>		
C950	0160-4259	CAP .22uF 10%
C951	0160-4259	CAP .22uF 10%
C952	0160-4048	CAP .022uF 20%
C953	0160-4048	CAP .022uF 20%
C956	0160-4065	CAP .1uF 20%
C957	0160-4065	CAP .1uF 20%
C958	0160-4835	CAP .1uF 10% 50V
C980	0160-4835	CAP .1uF 10% 50V
D980	1901-1098	DIO-IN4150
D981	1901-1098	DIO-IN4150
F980		
6680A	2110-0697	FU-SUBMIN 15A
6681A	2110-0697	FU-SUBMIN 15A
6682A	2110-0916	FU-SUBMIN 7A
6683A	2110-0916	FU-SUBMIN 7A
6684A	2110-0916	FU-SUBMIN 7A
F981		
6680A	2110-0697	FU-SUBMIN 15A
6681A	2110-0697	FU-SUBMIN 15A
6682A	2110-0916	FU-SUBMIN 7A
6683A	2110-0916	FU-SUBMIN 7A
6684A	2110-0916	FU-SUBMIN 7A
Q980	1853-0510	XSTR PNP
R940		
6680A	0811-3705	RES .01 3W
6681A	0811-3705	RES .01 3W
6682A	0811-3691	RES .025 3W
6683A	0811-3691	RES .025 3W
6684A	0699-1060	RES .05 3W
R941		
6680A	0811-3705	RES .01 3W
6681A	0811-3705	RES .01 3W
6682A	0811-3691	RES .025 3W
6683A	0699-1060	RES .05 3W
6684A	0699-1060	RES .05 3W
R945		
6680A	0698-3609	RES 22 5% 2W MO
6681A	0698-3614	RES 43 5% 2W MO
6682A	0698-3633	RES 390 5% 2W MO
6683A	0698-3637	RES 820 5% 2W MO
6684A	0698-3338	RES 1.5K 5% 2W MO
R946		
6680A	0698-3609	RES 22 5% 2W MO
6681A	0698-3614	RES 43 5% 2W MO
6682A	0698-3633	RES 390 5% 2W MO
6683A	0698-3637	RES 820 5% 2W MO
6684A	0698-3338	RES 1.5K 5% 2W MO

**Table 5-13. A9 Down Programmer/Slow Sense, Replaceable Parts (continued)**

Ref. Desig.	HP Part No.	Description
R950	0683-5605	RES 56 5% .25W
R951	0683-5605	RES 56 5% .25W
R952	0683-5605	RES 56 5% .25W
R953	0683-5605	RES 56 5% .25W
R954	0699-0208	RES 1 5% .25W CF
R955	0699-0208	RES 1 5% .25W CF
R958	0699-0208	RES 1 5% .25W CF
R959	0699-0208	RES 1 5% .25W CF
R960	0683-2755	RES 2.7M 5% .25W
R961	not used	
R980	0757-0451	RES 24.3K 1%
R981	0698-4416	RES 169 1% .125W
R982	0757-0273	RES 3.01K 1%
R983	0698-0082	RES 464 1% .125W
R984	0698-0082	RES 464 1% .125W
U900		
6680A	1826-0890	IC 358A
6681A	1826-0890	IC 358A
6682A	1826-1409	LT1013
6683A	1826-1409	LT1013
6684A	1826-1409	LT1013
Z900	1902-0960	DIO ZNR 12V 5%
Z901	1902-0960	DIO ZNR 12V 5%
Q981*		
6680A	1855-0874	POWER MOSFET
6681A	1855-0874	POWER MOSFET
6682A	1855-1003	POWER MODFET
6683A	1855-1003	POWER MODFET
6684A	1855-1003	POWER MODFET
Q982*		
6680A	1855-0874	POWER MOSFET
6681A	1855-0874	POWER MOSFET
6682A	1855-1003	POWER MODFET
6683A	1855-1003	POWER MODFET
6684A	1855-1003	POWER MODFET
	0340-1507	INSULATOR (REF Q981,982)
	5080-2212*	CABLE Ref: J910 to CONTROL J510
* not supplied as part of downprogrammer assy		

**Table 5-14. A10 Control Assembly, Replaceable Parts**

Ref. Desig.	HP Part No.	Description
<b>ELECTRICAL PARTS</b>		
C500	0180-4129	CAP 1uF 35V
C501	0180-4129	CAP 1uF 35V
C502	0180-4129	CAP 1uF 35V
C503	0160-4835	CAP .1uF 10% 50V
C504	0180-4129	CAP 1uF 35V
C505	0180-4131	CAP 4.7uF 35V
C506	0160-4835	CAP .1uF 10% 50V
C507	0180-4136	CAP 10uF 20V
C508	0160-4831	CAP 4700pF 10%
C509	0180-4129	CAP 1uF 35V
C510	0180-4129	CAP 1uF 35V
C511	0160-5422	CAP .047uF 20%
C512	0160-5644	CAP .033uF 10%
C513	0160-4789	CAP 15pF 5% 100V
C514	0160-4805	CAP 47pF 5% 100V
C515	0160-4805	CAP 47pF 5% 100V
C516	0160-5422	CAP .047uF 20%
C517	0180-4129	CAP 1uF 35V
C518	0160-4835	CAP 1uF 10% 50V
C519	0160-4835	CAP .1uF 10% 50V
C520	0160-4822	CAP 1000pF 5%
C521	0160-4832	CAP .01uF 10%
C530	0160-5422	CAP .047uF 20%
C531	0160-5422	CAP .047uF 20%
C532	0160-5422	CAP .047uF 20%
C533	0160-4801	CAP 100pF 5%
C534	0160-4801	CAP 100pF 5%
C535	0160-4801	CAP 100pF 5%
C536	0160-5422	CAP .047uF 20%
C537	0160-5422	CAP .047uF 20%
C538	0160-5422	CAP .047uF 20%
C539	0160-4846	CAP 1500pF 100V
C540	0160-5469	C-F 1uF 10% 50V
C541	0160-5469	C-F 1uF 10% 50V
C542	0160-5469	C-F 1uF 10% 50V
C543	0160-5469	C-F 1uF 10% 50V
C544	0160-4835	CAP .1uF 10% 50V
C545	0160-4801	CAP 100pF 5%
C546	0160-4801	CAP 100pF 5%
C547	0180-2264	C-F 3.3uF 15V
C548		
6680A	0160-4855	CAP 0.1uF 50V
6681A	0160-4855	CAP 0.1uF 50V
C556	0160-4835	CAP .1uF 10% 50V
C560	0160-4835	CAP .1uF 10% 50V
C561	0160-4904	CAP 6800pF 5%
C562	0160-4791	CAP 10pF 5% 100V

**Table 5-14. A10 Control Assembly, Replaceable Parts (continued)**

Ref. Desig.	HP Part No.	Description
C563	0160-4835	CAP .1uF 10% 50V
C564	0160-4835	CAP .1uF 10% 50V
C565	0160-4791	CAP 10pF 5% 100V
C566	0160-4795	CAP 4.7pF
C567	0160-4904	CAP 680pF 5%
C568	0160-4787	C-F 22pF 5% 100V
C569	0160-4787	C-F 22pF 5% 100V
C570	0160-4795	CAP 4.7pF
C571	0180-4129	CAP 1uF 35V
C572	0180-4131	CAP 4.7uF 35V
C573	0160-4835	CAP .1uF 10% 50V
C574	0160-4805	CAP 47pF 5% 100V
C575	0160-5098	CAP .22uF 10%
C576	0160-5098	CAP .22uF 10%
C577	0160-4824	CAP 680pF 100v
C578	0160-4824	CAP 680pF 100v
C579	0160-4835	CAP .1uF 10% 50V
C580	0160-4835	CAP .1uF 10% 50V
C581	0160-4797	CAP 3.3pF
C583	0160-4807	CAP 33pF 5% 100V
C584	0160-4797	CAP 3.3pF
C585	0160-4834	CAP .047uF 10%
C586	0160-4835	CAP .1uF 10% 50V
C587		
6680A	0160-4814	CAP 150pF 5%
6681A	0160-4801	CAP 100pF 5%
6682A	0160-4813	CAP 180pF 5%
6683A	0160-4813	CAP 180pF 5%
6684A	0160-4813	CAP 180pF 5%
C588	0160-4799	CAP 2.2pF 5%
C589		
6680A	not used	
6681A	not used	
6682A	0160-4824	CAP 680pF 5%
6683A	0160-4824	CAP 680pF 5%
6694A	0160-4824	CAP 680pF 5%
C590		
6680A	not used	
6681A	not used	
6682A	0160-4824	CAP 680pF 5%
683A	0160-4824	CAP 680pF 5%
6694A	0160-4824	CAP 680pF 5%
C591		
6680A	0160-4814	CAP 150pF 5%
6681A	0160-4801	CAP 100pF 5%
6682A	0160-4813	CAP 180pF 5%
6683A	0160-4813	CAP 180pF 5%
6684A	0160-4813	CAP 180pF 5%

Table 5-14. A10 Control Assembly, Replaceable Parts (continued)

Ref. Desig.	HP Part No.	Description
C592	0160-4835	CAP .1uF 10% 50V
C594	0160-4799	CAP 2.2pF
C595	0160-5098	CAP .22uF 10%
C596		
6680A	0160-4811	CAP 270pF 5%
6681A	0160-4811	CAP 270pF 5%
6682A	0160-4831	CAP 4700pF 5%
6683A	0160-4831	CAP 4700pF 5%
6684A	0160-4831	CAP 4700pF 5%
C597	0160-4795	CAP 4.7pF
C598		
6680A	0160-4831	CAP 4700pF 10%
6681A	0160-4831	CAP 4700pF 10%
6682A	0160-4830	CAP 2200pF 10%
6683A	0160-4830	CAP 2200pF 10%
6684A	0160-4831	CAP 4700pF 10%
C599	0160-4835	CAP .1uF 10% 50V
C600	0160-4835	CAP .1uF 10% 50V
C601	0160-4835	CAP .1uF 10% 50V
C621	0160-4795	CAP 4.7pF
C622		
6680A	0160-5534	CAP 0.1uF 10% 63V
6681A	0160-5534	CAP 0.1uF 10% 63V
6682A	0160-5534	CAP 0.1uF 10% 63V
6683A	0160-5534	CAP 0.1uF 10% 63V
6684A	0160-5534	CAP 0.1uF 10% 63V
C624		
6680A	0160-5267	CAP 4700pF 5%
6681A	0160-5410	CAP 3300pF 5%
6682A	0160-4904	CAP 6800pF 5%
6683A	0160-5267	CAP 4700pF 5%
6684A	0160-5267	CAP 4700pF 5%
C625		
6680A	0160-4819	CAP 2200pF 100V
6681A	0160-4846	CAP 1500pF 100V
6682A	0160-4821	CAP 1200pF 100V
6683A	0160-4824	CAP 680pF 10V
6684A	0160-4808	CAP 470pF 10V
C626	0180-4136	CAP 10uF 20V
C627	0180-4136	CAP 10uF 20V
C628	0160-4835	CAP .1uF 10% 50V
C629	0160-4799	CAP 2.2pF
C630		
6680A	0160-4904	CAP 6800pF 5%
6681A	0160-5410	CAP 3300pF 5%
6682A	0160-4812	CAP 220pF 5%
6683A	0160-4810	CAP 330pF 5%
6684A	0160-4810	CAP 330pF 5%

Table 5-14. A10 Control Assembly, Replaceable Parts (continued)

Ref. Desig.	HP Part No.	Description
-------------	-------------	-------------

C631		
6680A	0160-5534	CAP 0.1uF 10%
6681A	0160-5892	CAP 0.22uF 10%
6682A	0160-5469	CAP 1uF 10%
6683A	0160-5469	CAP 1uF 10%
6684A	0160-5469	CAP 1uF 10%
C632	0160-4791	CAP 10pF 5% 100V
C633	0160-4791	CAP 10pF 5% 100V
C635		
6680A	0160-5468	CAP 0.47uF 10% 50V
6681A	0160-5469	CAP 1uF 10% 50V
6682A	0160-5892	CAP 0.22uF 10% 50V
6683A	0160-5468	CAP 0.47uF 10% 50V
6684A	0160-5468	CAP 0.47uF 10% 50V
C636		
6680A	0160-5468	CAP 0.47uF 10% 50V
6681A	0160-5469	CAP 1uF 10% 50V
6682A	0160-5892	CAP 0.22uF 10% 50V
6683A	0160-5468	CAP 0.47uF 10% 50V
6684A	0160-5468	CAP 0.47uF 10% 50V
C637		
6680A	0160-4808	CAP 470pF 5%
6681A	0160-4808	CAP 470pF 5%
6682A	0160-4812	CAP 220pF 5%
6683A	0160-4812	CAP 220pF 5%
6684A	0160-4812	CAP 220pF 5%
C639	0160-4795	CAP 4.7pF
C640	0160-4835	CAP .1uF 10% 50V
C641	0160-5410	CAP 3300pF 5%
C645	0160-4805	CAP 47pF 5% 100V
C648	0160-4831	CAP 4700pF 10%
C650	0160-4833	CAP .022uF 10%
C651	0160-7277	CAP 2.2uF 50V
C652	0160-4832	CAP .01uF 10%
C653	0160-5892	CAP 0.22uF 10%
C654	0160-4183	CAP 1000pF 20%
C655	0160-4183	CAP 1000pF 20%
C656		
6680A	0160-5892	CAP 0.22uF 10%
6681A	0160-5892	CAP 0.22uF 10%
6682A	0160-5469	CAP 1uF 10% 50V
6683A	0160-5469	CAP 1uF 10% 50V
6684A	0160-5469	CAP 1uF 10% 50V
C657		
6680A	not used	
6681A	not used	
6682A	0160-5534	CAP 0.1uF 10%
6683A	0160-5534	CAP 0.1uF 10%
6684A	0160-5534	CAP 0.1uF 10%

**Table 5-14. A10 Control Assembly, Replaceable Parts (continued)**

Ref. Desig.	HP Part No.	Description
C658	0160-4183	CAP 1000pF 20%

C659	0160-4183	CAP 1000pF 20%
C710	0160-4835	CAP .1uF 10% 50V
C711	0160-4835	CAP .1uF 10% 50V
C715		
6680A	not used	
6681A	not used	
6682A	0160-4824	CAP 680pF 5%
6683A	0160-4824	CAP 680pF 5%
6684A	0160-4824	CAP 680pF 5%
C735	0683-1005	RES 10 5% .25W
D500	1901-0731	DIO-PWR RECT
D501	1901-0731	DIO-PWR RECT
D502	1901-0731	DIO-PWR RECT
D503	1901-1098	DIO-1N4150
D504	1901-1098	DIO-1N4150
D505	1901-1098	DIO-1N4150
D506	1901-1098	DIO-1N4150
D507	1901-1098	DIO-1N4150
D508	1901-1098	DIO-1N4150
D530	1901-1098	DIO-1N4150
D531	1901-1098	DIO-1N4150
D532	1901-1098	DIO-1N4150
D533	1901-1098	DIO-1N4150
D534	1901-1098	DIO-1N4150
D535	1901-1098	DIO-1N4150
D536	1901-1098	DIO-1N4150
D538	1901-1098	DIO-1N4150
D539	1901-0880	DIO GEN PRP
D540	1901-1098	DIO-1N4150
D560	1901-0880	DIO GEN PRP
D561	1901-0880	DIO GEN PRP
D637	1901-1098	DIO-1N4150
D651	1901-1098	DIO-1N4150
D652	1901-1098	DIO-1N4150
D653	1901-0880	DIO GEN PRP
D654	1901-0880	DIO GEN PRP
D655	1901-1098	DIO-1N4150
D656	1901-1098	DIO-1N4150
D657	1901-0880	DIO GEN PRP
D658	1901-1098	DIO-1N4150
D659	1901-1098	DIO-1N4150
D670	1901-0880	DIO GEN PRP
D671	1901-1098	DIO-1N4150
D672	1901-0880	DIO GEN PRP
D673	1901-0880	DIO GEN PRP
D674	1901-0880	DIO GEN PRP
D675	1901-0880	DIO GEN PRP

**Table 5-14. A10 Control Assembly, Replaceable Parts (continued)**

Ref. Desig.	HP Part No.	Description
D676	1901-0880	DIO GEN PRP
D677	1901-1098	DIO-1N4150



D678	1901-1098	DIO-1N4150
D679	1901-1098	DIO-1N4150
D680	1901-1098	DIO-1N4150
J507	1251-7330	PHONE RECEPTABLE
J509	1252-1992	CONNECTOR 16 pin
J510	1252-1152	CONNECTOR 10 pin
J511	1252-0055	CONNECTOR 2 pin
J512	1252-0056	CONNECTOR 4 pin
J513	1252-3693	CONNECTOR 7 pin
L500	9140-0158	COIL IUH 10%
Q610	1853-0510	XSTR PNP
Q621	1855-0413	J-FET P-CHAN
Q622	1855-0413	J-FET P-CHAN
Q623	1855-0413	J-FET P-CHAN
R500	0757-0346	RES 10 1% .125W
R501	0698-3155	RES 4.64K 1%
R502	0698-3155	RES 4.64K 1%
R503	0757-0273	RES 3.01K 1%
R504	0757-0442	RES 10K 1% .125W
R505	0757-0434	RES 3.65K 1%
R506	0757-0289	RES 13.3K 1%
R507	0698-3155	RES 4.64K 1%
R508	0698-6323	RES 100.1%
R509	0757-0442	RES 10K 1% .125W
R510	0757-0289	RES 13.3K 1%
R511	0698-3155	RES 4.64K 1%
R512	0757-0472	RES 200K 1%
R513	0757-0199	RES 21.5K 1%
R514	0698-3279	RES 4.99K 1%
R515	0757-0472	RES 200K 1%
R516	0698-3456	RES 287K 1%
R517	0698-3279	RES 4.99K 1%
R518	0757-0442	RES 10K 1% .125W
R519	0698-3279	RES 4.99K 1%
R520	0757-0442	RES 10K 1% .125W
R521	0757-0465	RES 100K 1%
R522	0757-0289	RES 13.3K 1%
R523	0757-0280	RES 1K 1% .125W
R524	0698-8827	RES 1M 1% .125W
R525	0757-0442	RES 10K 1% .125W
R526	0757-0442	RES 10K 1% .125W
R527	0699-1212	RES 19K .1%
R528	0698-6392	RES 22K .1%.125W
R529	0757-0283	RES 2K 1% .125W
R530	1810-0305	NETWORK-RES SIP
R531	0698-4446	RES 267 1% .125W
R532	0757-0273	RES 3.01K 1%

**Table 5-14. A10 Control Assembly, Replaceable Parts (continued)**

Ref. Desig.	HP Part No.	Description
R533	0698-3155	RES 4.64K 1%
R534	0699-0070	RES 3.16M 1%
R535	0757-0468	RES 130K 1%

R536		
6680A	0757-0290	RES 6.19K 1% .125W
6681A	0757-0442	RES 10K 1% .125W
6682A	0698-4486	RES 24.9K 1%
6683A	0698-6076	RES 39K 1%
6684A	0757-0457	RES 47.5K 1%
R537		
6680A	8159-0005	RES 0.0
6681A	0698-8827	RES IM 1%
6682A	0699-0070	RES 3.16M 1%
6683A	0699-0070	RES 3.16M 1%
6684A	not used	
R538		
6680A	0698-8827	RES IM 1%
6681A	0698-8827	RES IM 1%
6682A	0699-1972	RES 1.74M 1%
6683A	0699-0070	RES 3.16K
R539	0757-0438	RES 5.11K 1%
R540	0757-0428	RES 1.62K 1%
R550	0757-0401	RES 100 1% .125W
R551	0757-0401	RES 100 1% .125W
R552	0757-0401	RES 100 1% .125W
R553	0757-0465	RES 100K 1%
R554	0757-0465	RES 100K 1%
R555	0757-0462	RES 75K 1% .125W
R556	0698-3450	RES 42.2K 1%
R557	0757-0280	RES 1K 1% .125W
R558	0698-3456	RES 287K 1%
R559	0698-3456	RES 287K 1%
R560	0698-4486	RES 24.9K 1%
R561	0698-4486	RES 24.9K 1%
R562	0698-4486	RES 24.9K 1%
R563	0698-4486	RES 24.9K 1%
R564	0699-0642	RES 10K .1% .1W
R565	0699-0642	RES 10K .1% .1W
R566	0699-0642	RES 10K .1% .1W
R567	0699-0642	RES 10K .1% .1W
R568	0698-3279	RES 4.99K 1%
R569	0698-3279	RES 4.99K 1%
R570	0757-0424	RES 1.1K 1%
R580	0757-0434	RES 3.65K 1%
R581	0757-0407	RES 200 1% .125W
R582	0698-4486	RES 24.9K 1%
R583	0698-4486	RES 24.9K 1%
R584	0757-0472	RES 200K 1%
R585	0757-0434	RES 3.65K 1%

**Table 5-14. A10 Control Assembly, Replaceable Parts (continued)**

Ref. Desig.	HP Part No.	Description
R586	0757-0472	RES 200K 1%
R587	0757-0407	RES 200 1% .125W
R588	0757-0442	RES 10K 1% .125W
R589	0757-0442	RES 10K 1% .125W

R590	0699-0070	RES 3.16M 1%
R591	0757-0472	RES 200K 1%
R592	0757-0472	RES 200K 1%
R593	0699-0070	RES 3.16M 1%
R594	0757-0280	RES 1K 1% .125W
R595	0757-0273	RES 3.01K 1%
R596	0757-0442	RES 10K 1% .125W
R597	0757-0199	RES 21.5K 1%
R598	0757-0273	RES 3.01K 1%
R599	0757-0427	RES 1.5K 1%
R600	0757-0427	RES 1.5K 1%
R601	0757-0401	RES 100 1% .125W
R602	0757-0401	RES 100 1% .125W
R603	0698-4446	RES 267 1% .125W
R604	0698-3279	RES 4.99K 1%
R605	0698-3430	RES 21.5 1%
R606	0698-3430	RES 21.5 1%
R607	0698-4479	RES 14K 1% .125W
R608	0757-0429	RES 1.82K 1%
R609	0757-0429	RES 1.82K 1%
R610		
6680A	0757-0462	RES 75K 1%
6681A	0757-0465	RES 100K 1%
6682A	0757-0465	RES 100K 1%
6683A	0757-0465	RES 100K 1%
6684A	0757-0465	RES 100K 1%
R611	0698-3450	RES 42.2K 1%
R612	0757-0442	RES 10K 1% .125W
R613	0698-3155	RES 4.64K 1%
R614	0698-3279	RES 4.99K 1%
R615	0698-3162	RES 46.4K 1%
R616	0757-0410	RES 301 1% .125W
R617	0698-0082	RES 464 1% .125W
R618	0757-0410	RES 301 1% .125W
R619	0757-0453	RES 30.1K 1%
R620		
6680A	not used	
6681A	not used	
6682A	0698-3136	RES 17.8K 1%
6683A	0757-0446	RES 15K 1%
6684A	0757-0446	RES 15K 1%

**Table 5-14. A10 Control Assembly, Replaceable Parts (continued)**

Ref. Desig.	HP Part No.	Description
R621		
6680A	0757-0453	RES 30.1K 1%
6681A	0757-0453	RES 30.1K 1%
6682A	0757-0462	RES 75K 1%
6683A	0757-0467	RES 121K 1%

6684A	0757-0469	RES 150K 1%
R622		
6680A	not used	
6681A	not used	
6682A	0698-3136	RES 17.8K 1%
6683A	0757-0446	RES 15K 1%
6684A	0757-0446	RES 15K 1%
R623		
6680A	0757-0453	RES 30.1K 1%
6681A	0757-0453	RES 30.1K 1%
6682A	0757-0462	RES 75K 1%
6683A	0757-0467	RES 121K 1%
6684A	0757-0469	RES 150K 1%
R624	0757-0453	RES 30.1K 1%
R625		
6680A	0698-3455	RES 261K 1%
6681A	0698-3455	RES 261K 1%
6682A	0757-0461	RES 68.1K 1%
6683A	0699-1972	RES 1.74M 1%
6684A	0699-1972	RES 1.74M 1%
R626		
6680A	0698-3455	RES 261K 1%
6681A	0698-3455	RES 261K 1%
6682A	0699-0088	RES 1.21M 1%
6683A	0757-0480	RES 432K 1%
6684A	0757-0480	RES 432K 1%
R627	0698-3455	RES 261K 1%
R628	0698-3455	RES 261K 1%
R629	0698-4479	RES 14K 1% .125W
R632	0757-0273	RES 3.01K 1%
R633	0757-0465	RES 100K 1%
R634	0757-0442	RES 10K 1% .125W
R635	0698-3450	RES 42.2K 1%
R636	0757-0280	RES 1K 1% .125W
R637		
6680A	0757-0465	RES 100K 1%
6681A	0757-0465	RES 100K 1%
6682A	0757-0465	RES 100K 1%
6683A	0757-0466	RES 110K 1%
6684A	0757-0464	RES 90.0K 1%
R638	0698-3279	RES 4.99K 1%

**Table 5-14. A10 Control Assembly, Replaceable Parts (continued)**

Ref. Desig.	HP Part No.	Description
R639		
6680A	0757-0463	RES 82.5K 1%
6681A	0757-0463	RES 82.5K 1%
6682A	0757-0464	RES 90.9K 1%
6683A	0757-0466	RES 110K 1%
6684A	0757-0464	RES 90.9K 1%
R640	0698-3279	RES 4.99K 1%
R641		
6680A	0757-0452	RES 27.4K 1%
6681A	0757-0452	RES 27.4K 1%
6682A	0698-3156	RES 14.7K 1%
6683A	0698-3156	RES 14.7K 1%
6684A	0698-3156	RES 14.7K 1%
R642	0757-0410	RES 301 1%
R643	0757-0429	RES 1.82K 1%
R644	0757-0434	RES 3.65K 1%
R645		
6680A	0698-8827	RES IM 1%
6681A	0699-0070	RES 3.16M 1%
6682A	0699-0070	RES 3.16M 1%
6683A	0699-0070	RES 3.16M 1%
6684A	0699-0070	RES 3.16M 1%
R646		
6680A	0699-0088	RES 1.2M 1%
6681A	0699-0088	RES 1.2M 1%
6682A	0698-3215	RES 499K 1%
6683A	0698-3215	RES 499K 1%
6684A	0698-3215	RES 499K 1%
R658	0757-0278	RES 1.78K 1%
R659	0757-0278	RES 1.78K 1%
R660	0698-8827	RES IM 1% .125W
R661		
6680A	0757-0433	RES 3.32K 1%
6681A	0757-0430	RES 2.21K 1%
6682A	0757-0427	RES 1.5K 1%
6683A	0757-0280	RES IK 1%
6684A	0757-0280	RES IK 1%
R662	0757-0273	RES 3.01K 1%
R663	0698-3456	RES 287K 1%
R664	0698-3155	RES 4.64K 1%
R665	0757-0273	RES 3.01K 1%
R666		
6680A	0698-8913	RES 1.5M 1%
6681A	0683-2255	RES 2.2M 1%
6682A	0683-2255	RES 2.2M 1%
6683A	0683-4755	RES 4.7M 1%
6684A	0683-5655	RES 5.6M 1%

**Table 5-14. A10 Control Assembly, Replaceable Parts (continued)**

Ref. Desig.	HP Part No.	Description
R667		
6680A	0757-0465	RES 100K 1
6681A	0757-0462	RES 75K 1%
6682A	0698-3455	RES 261K 1%
6683A	0698-3455	RES 261K 1%
6684A	0757-0473	RES 221K 1%
R668	0698-3279	RES 4.99K 1
R669		
6680A	0757-0462	RES 75K 1%
6681A	0698-4503	RES 66.5K 1%
6682A	0757-0273	RES 3.01K 1%
6683A	0757-0480	RES 432K 1%
6684A	0698-3456	RES 287K 1%
R670		
6680A	0699-1742	RES 70K 1%
6681A	0699-1211	RES 95K 1%
6682A	0699-1211	RES 95K 1%
6683A	0699-0460	RES 85K 1%
6684A	0699-0460	RES 85K 1%
R671	0699-0070	RES 3.16M 1%
R672		
6680A	0698-8093	RES 40K 1%
6681A	0699-0118	RES 20K 1%
6682A	0699-0118	RES 20K 1%
6683A	0699-0461	RES 30K .1%
6684A	0699-0461	RES 30K .1%
R673	0699-2247	RES 121K .05%
R674	0699-0461	RES 30K .1% .1W
R675	0698-3279	RES 4.99K 1%
R677	0699-0461	RES 30K .1% .1W
R678		
6680A	0699-3414	RES 45K
6681A	0699-2246	RES 25K 0.05%
6682A	0699-2246	RES 25K 0.05%
6683A	0699-2246	RES 25K 0.05%
6684A	0699-2246	RES 25K 0.05%
R679		
6680A	0699-3414	RES 45K
6681A	0699-2246	RES 25K 0.05%
6682A	0699-2246	RES 25K 0.05%
6683A	0699-2246	RES 25K 0.05%
6684A	0699-2246	RES 25K 0.05%
R680		
6680A	0699-3103	RES 19K 0.05%
6681A	0699-3103	RES 19K 0.05%
6682A	0699-2248	RES 47.5K 0.05%
6683A	0699-2879	RES 80K 0.05%
6684A	0699-3416	RES 100K 0.05%

Table 5-14. A10 Control Assembly, Replaceable Parts (continued)

Ref. Desig.	HP Part No.	Description
R681		
6680A	0699-3103	RES 19K 0.05%
6681A	0699-3103	RES 19K 0.05%
6682A	0699-2248	RES 47.5K 0.05%
6683A	0699-2879	RES 80K 0.05%
6684A	0699-3416	RES 100K 0.05%
R682		
6680A	0698-6322	RES 4K 0.1%
6681A	0698-7163	RES 2.0081K 0.1%
6682A	0698-8061	RES 8.25K 0.1%
6683A	0698-6322	RES 4K 0.1%
6684A	0698-6322	RES 4K 0.1%
R683		
6680A	0698-6322	RES 4K 0.1%
6681A	0698-7163	RES 2.0081K 0.1%
6682A	0698-8061	RES 8.25K 0.1%
6683A	0698-6322	RES 4K 0.1%
6684A	0698-6322	RES 4K 0.1%
R684		
6680A	0757-0280	RES 1K 1%
6681A	0757-0289	RES 1K 1%
6682A	0757-0430	RES 2.21K 1%
6683A	0698-3496	RES 3.57K 1%
6684A	0757-0436	RES 4.32K 1%
R685		
6680A	0757-0280	RES 1K 1%
6681A	0757-0289	RES 1K 1%
6682A	0757-0430	RES 2.21K 1%
6683A	0698-3496	RES 3.57K 1%
6684A	0757-0436	RES 4.32K 1%
R686		
6680A	8159-0005	RES 0.0
6682A	0698-8911	RES 1.3K .1%
6683A	0699-0486	RES 2.0K .1%
6684A	8159-0005	RES 0.0
R687	0698-8093	RES 40K .1% .1W
R689	0698-5365	RES 3.48K .1%
R690		
6680A	0757-0395	RES 56.2
6681A	0757-0395	RES 56.2
6682A	0757-0403	RES 121
6683A	0757-0403	RES 121
6684A	0698-6362	RES 1.0K .1%
R691		
6680A	0699-1011	RES 3.32K .1%
6681A	0699-1011	RES 3.32K .1%
6682A	0698-8911	RES 1.3K .1%
6683A	0698-7163	RES 2.0081K .1%
6684A	0698-8911	RES 1.3K .1%

Table 5-14. A10 Control Assembly, Replaceable Parts (continued)

Ref. Desig.	HP Part No.	Description
-------------	-------------	-------------

R692	0698-6620	RES 150K .1%
R693	0698-3430	RES 21.5 1%
R694	0698-3430	RES 21.5 1%
R695	0698-8093	RES 40K .1% .1W
R696	0698-6414	RES 1K .1% .1W F
R697	0698-6414	RES 1K .1% .1W F
R698	0698-6323	RES 100 1%
R699	0698-6323	RES 100.1%
R701	0757-0442	RES 10K 1% .125W
R702	0757-0442	RES 10K 1% 125W
R703		
6680A	0757-0446	RES 15K 1%
6681A	0757-0443	RES 11K 1%
6682A	0757-0443	RES 11K 1%
6683A	0757-0443	RES 11K 1%
6684A	0757-0443	RES 11K 1%
R704	0683-1065	RES 10M 5% .25W
R705		
6680A	0699-0070	RES 3.16M
6681A	0683-2255	RES 2.2M
6682A	0683-2255	RES 2.2M
6683A	0683-2255	RES2.2M
6684A	0683-2255	RES 2.2M
R706	8159-0005	RES-ZERO OHMS
R707		
6680A	0699-0088	RES 1.21M
6681A	0698-8826	RES 825K
6682A	0698-8826	RES 825K
6683A	0698-8826	RES 825K
6684A	0698-8826	RES 825K
R708		
6680A	0698-3459	RES 383K
6681A	0698-3455	RES 261K
6682A	0698-3455	RES 261K
6683A	0698-3455	RES 261K
6684A	0698-3455	RES 261K
R709		
6680A	0757-0468	RES 130K
6681A	0757-0464	RES 90.9K
6682A	0757-0464	RES 90.9K
6683A	0757-0464	RES 90.9K
6684A	0757-0464	RES 90.9K
R710		
6680A	0698-5091	RES 45K
6681A	0698-3160	RES 31.6K
6682A	0698-3160	RES 31.6K
6683A	0698-3160	RES 31.6K
6684A	0698-3160	RES 31.6K
R711	0698-5091	RES 45K

**Table 5-14. A10 Control Assembly, Replaceable Parts (continued)**

Ref. Desig.	HP Part No.	Description
R712	0698-0082	RES 464 1% .125W



R713	0757-0442	RES 10K 1% .125W
R714	0757-0349	RES 22.6K 1%
R715	0757-0447	RES 16.2K 1%
R716	0698-3449	RES 28.7K 1%
R717		
6680A	not used	
6681A	not used	
6682A	0757-0442	RES 10K
6683A	0757-0442	RES 10K
6684A	0757-0442	RES 10K
R718	0698-3162	RES 46.4K 1%
R719	0757-0458	RES 51.1K 1%
R720	0698-8093	RES 40K .1% .1W
R721	0698-6630	RES 20K .1%
R724	0698-3279	RES 4.99K 1%
R725		
6680A	not used	
6681A	not used	
6682A	0757-0199	RES 21.5K
6683A	0757-0199	RES 21.5K
6684A	0757-0199	RES 21.5K
R726	0698-6359	RES 80K .1%
R727	0698-6630	RES 20K .1%
R728	0698-6630	RES 20K .1%
R729	0698-6359	RES 80K .1%
R730	0698-6630	RES 20K .1%
R731	0698-6630	RES 20K .1%
R732	0698-6619	RES 15K .1%
R733	0699-0489	RES 16.15K .1%
R734	0683-2255	RES 2.2M 5% .25W
R738	0698-8959	RES 619K 1%
R741		
6680A	0757-0429	RES 1.82K
6681A	0698-3496	RES 3.57K
6682A	0757-0436	RES 4.32K
6683A	0698-3496	RES 3.57K
6684A	0698-3151	RES 2.87K
R742	0698-4509	RES 80.6K 1%
R743	0698-8093	RES 40K .1% .1W
R744	0683-0475	RES 4.7 5% .25W
R745	0698-6630	RES 20K .1%
RT500	0837-0397	Thermistor
S500	3101-1973	SW-SL 7-1A
U500	1826-2341	IC-REG TL7702BCP
U501	1826-1370	IC 365
U502	1826-1370	IC 365
U503	1826-0346	IC OP AMP
U504	1826-1369	IC-VOLTAGE REG

**Table 5-14. A10 Control Assembly, Replaceable Parts (continued)**

Ref. Desig.	HP Part No.	Description
U506	5080-2305	PRGMD-IC, SEC
U507	1820-3079	IC MC74HC138N

U510	1826-2187	IC-CONVERTER,DIA
U511	1826-2187	IC-CONVERTER,DIA
U512	1826-2187	IC-CONVERTER,DIA
U513	1826-1896	IC-LINEAR
U514	1826-1896	IC-LINEAR
U515	1826-1896	IC-LINEAR
U516	1826-1370	IC 365
U517	1826-1370	IC 365
U518	1820-3081	IC MC74HC74N
U520	1826-1231	DIA 8-DGT
U521	1826-1409	IC 1013
U522	1826-1409	IC 1013
U600	1820-3199	IC MC74HC4040N
U601	1820-2922	IC MC74HC00N
U602	1820-3081	IC MC74HC74N
U603	1826-2343	IC-VRGLTR,SWG
U604	1820-2922	IC MC74HC00N
U605	1826-0065	IC 311
U606	1858-0083	XSTR ARY 14P-DIP
U607	1826-0962	IC 412
U608	1826-0962	IC 412
U609	1826-0890	IC 358A
U610	1826-1343	IC-VOLTAGE REG
U620	1826-1409	IC 1013
U621	1826-1409	IC 1013
U622	1826-1895	PRECISION OP-AMP
U623	1826-1896	IC-LINEAR
U624	1826-0161	IC 324
Z500	1902-0777	DIO-ZNR IN825
Z501	1902-3114	DIO-ZNR 6.19V 2%
Z641	1902-1377	DIO-ZNR 6.19V

# Diagrams

---

## Introduction

This chapter contains drawings and diagrams for troubleshooting and maintaining HP Series 668xA Power Supplies. Unless otherwise specified, a drawing or diagram applies to all models of the series. Wiring connections to external equipment are shown in the Power Supply Operating Manual.

---

## Chapter Organization

Table 6-1 summarizes the contents of this chapter.

**Table 6-1. Summary of Chapter Contents**

Function	Description	See
Interconnections	Drawing identifying each circuit board, the cables between boards, and schematic diagram for each board.	Figure 6-2
Schematics	Show test points, signal mnemonics, component-location grid coordinates, and specific notes. General notes applicable to all schematics are given in Table 6-4. A1 Front Panel Board. LED Board. A2 HP-IB Board. A3 FET Board. A4 AC Input Power Board. A5 DC Rail Board. A6 Bias Board. A7 Snubber Board. A8 Fast Sense Board. A9 Down Programming/Slow Sense Board. A10 Control Board.	
Signal names	Table of signal name mnemonics	Table 6-2
Parts location	A drawing that shows the location of components on a circuit board is located next to the above circuit board schematic diagram.  A drawing showing location of each circuit board in the chassis is in Chapter 3.	Figure 3-18
Test points	Description of each test point. Location of each test point is shown on the appropriate schematic and its associated parts location drawing.	Table 6-3

**Table 6-2. Signal Name Mnemonics**

<b>Mnemonic</b>	<b>Description</b>	<b>Mnemonic</b>	<b>Description</b>
A(0)--A(15)	Address lines	MSRQ	Microprocessor service request
AD (0)--AD(7)	Address bus	NDAC	Not data accepted (HP-IB)
AMB_SENSE	Ambient temperature sense	NEG_IMON	Negative current monitor
ANA(0)--ANA(7)	Analog Signal readback bus	NRFD	Not ready or data (HP-IB)
ATN	Attention (HP-IB)	OV	Overvoltage
BIAS_OK	±15V bias supplies have stabilized	OV_CLR	Overvoltage clear
BOVPROG	BuFfered OV programming	OVCMP	Overvoltage comparator
BSTX	BuFfered secondary transmit	OVP_BIAS	Overvoltage protection bias
cc	Constant current status	OVPROG	Overvoltage programming
CCPROG	Constant current programming	OVSCR	Overvoltage SCR (crowbar)
cv	Constant voltage status	PCLR	Primary power clear
CVPROG	Constant voltage programming	PREF	Primary reference voltage (2.53V)
D(0)_D(7)	Data lines	PREF_2	Primary reference voltage (1.0V)
D101--DI08	Data lines (HP-IB)	PREN	Primary remote enable
DAV	Data valid (HP-IB)	PRX	Primary receive serial data
DFI	Discrete fault indicator	PTX	Primary transmit serial data
DFI-EN	Discrete fault indicator enable	PWM_EN	Pulse width modulator enable
DPS	Downprogramming shunt	RAM	Random access memory
DN_PGM	Down programming	RDY	Ready
DRIVE_A/B	FET drive signals	REN	Remote enable
EOI	End or identify (HP-IB)	RI	Remote inhibit
FAC_CAL	Factory calibration	ROM	Read only memory
FAN_PWM	Fan pulse width modulation	SPCLR	Secondary power clear
FPRX	Front panel receive serial data	RX	Receive serial data
FPTX	Front panel transmit serial data	RxD	Receive Serial Data
FS	Fast sense	SA	Signature analysis
HSRQ	HP-IB service request	SRQ	Service request (HP-IB)
IFC	Interface clear (HP-IB)	SRX	Secondary receive serial data
IMON	Current monitor	STX	Secondary transmit serial data
INH_CAL	Inhibit calibration	TxD	Transmit Serial Data
IP	External current programming	UART	Universal asynchronous receive/transmit
IPROG	Current programming	VMON	Voltage monitor
ISEN	Current sense	vos	Voltage offset
ISRQ	Interface service request	VPROG	Voltage programming
KO(0)-KO(5)	Keypad output data bus	WR	Write
KI(0)--KI(5)	Keypad input data bus		

**Table 6-3. Test Points**

TEST POINT No. & Loc.	Signal Tested	Measurement and Conditions
<b>A2 HP-IB BOARD</b>		
<p><b>1</b> J106-4</p> <p><b>2</b> U101-1</p> <p><b>3</b> U101-6</p> <p><b>4</b> U101-8</p> <p><b>5</b> U110-3</p> <p><b>6</b> U111-6</p> <p><b>7</b> U119-4</p> <p><b>8</b> U119-18</p>	<p>Primary/chassis ground</p> <p>+ 5V primary bias</p> <p>PCLR</p> <p>PCLR*</p> <p>STX</p> <p>SRX</p> <p>FPRX</p> <p>FPTX</p>	<p>Connect meter or scope common here. Then make measurements at test points <b>2</b> through <b>8</b>.</p> <p>+ 5V ± 0.2V</p> <p>Goes high for approximately 40 ms at power on, then goes low.</p> <p>Held low for approximately 40 ms at power on, then goes high.</p> <p>Primary transmit to secondary serial data line. Toggles between 0 and +5V.</p> <p>Primary receive from secondary serial data line. Toggles between 0 and +5V.</p> <p>Primary receive from front panel serial data line. Toggles between 0 and +5V.</p> <p>Primary transmit to front panel serial data line. Toggles between 0 and +5V.</p>
<b>AC Input Board</b>		
<p>Connect meter between TP <b>9</b> and <b>10</b>, or <b>9</b> and <b>11</b>, or <b>10</b> and <b>11</b>, and measure approximately 220VAC or 440VAC. Measurements at test points <b>9</b> through <b>11</b>.</p>		
<p><b>9</b> J418-1/J417-7</p> <p><b>10</b> J418-2/J417-8</p> <p><b>11</b> J418-3/J417-9</p> <p><b>12</b> K402 coil</p>	<p>AC Mains Voltage</p> <p>AC Mains Voltage</p> <p>AC Mains Voltage</p> <p>24VDC Coil Voltage</p>	<p>Turns on PS, and after power-on initialization test, reads approximately 24VDC.</p>
<b>DC Rail Board</b>		
<p><b>13</b> J430-1 (+) to J430-2 (-)</p> <p><b>14</b> J431-1 (+) to J431-2 (-)</p>	<p>Rail #1 Voltage</p> <p>Rail #2 Voltage</p>	<p>Measure approximately 290VDC</p> <p>Measure approximately 290VDC</p>
<b>Bias Board</b>		
<p><b>15</b> J801-4 to J801-5</p> <p><b>16</b> J801-1 (+) to J801-2 (-)</p> <p><b>17</b> J827-1 (+) to J827-2 (-)</p> <p><b>18</b> J827-1 (+) to J827-3 (-)</p> <p><b>19</b> R331</p> <p><b>16</b> R330</p> <p><b>17</b> +C354</p> <p><b>18</b> U310-16</p> <p><b>18</b> U308-6</p> <p><b>20</b> U308-7</p>	<p>HPIB 5V Bias</p> <p>Fan voltage</p> <p>Inrush relay coil</p> <p>Rail relay coil</p> <p>24V Primary</p> <p>-15Vs secondary bias</p> <p>-25V</p> <p>RELAY ON*</p> <p>RESET</p> <p>BIAS OK</p>	<p>+15 ± 0.9V measure approx. 11VAC</p> <p>Measure 24VDC</p> <p>Measure 24VDC</p> <p>Measure 24VDC after power-on initialization test.</p> <p>Measure approximately 34VAC</p> <p>-15 ± 0.9V</p> <p>-22.5V to -27.5V</p> <p>0V</p> <p>0V</p> <p>+5V</p>

**Table 6-3. Test Points (continued)**

TEST POINT No. & Loc.	Signal Tested	Measurement and Conditions
<b>Bias Board (continued)</b>		
(21) U308-1	PREF	+2.5V
(22) U308-5	RESET*	Held low for approximately 50 ms at power-on, then goes high.
(23) U311-7	FAN DETECT	+3V
(24) D317	-25V	+3V
(25) U311-2	FAN_PWN	+0.6V
<b>A3 FET Board</b>		
Test points (26) through (35) are on the A3 FET Board. Troubleshooting procedures at these points are given under Dynamic Troubleshooting section of the FET Troubleshooting Chart (Table 3-4).		
<b>A10 Control Board</b>		
(36) +C500	Secondary common (Sheet 1)	
(37) U504-6	CC/CC DACs reference (Sheet 1)	
(38) U503-7	Readback DAC reference (Sheet 1)	
(39) U513-6	CVPROG (Sheets 2,4)	
(40) U514-6	CVPROG (Sheets 2,4)	
	<b>NOTE:</b> Measurements at test points through where taken under the following conditions:	
	1. Programming	a. Voltage = ½ scale b. Current = ½ scale c. OV = full scale
	2. First measurement in CV mode with no load.	
	3. Second measurement in CC mode with output shorted.	
(41) U621-1	VMON (Sheet 4)	
(42) U621-7	CV CONTROL (Sheet 4)	
(43) U502-2	CV* (Sheet 4)	CV mode =0V      CC mode = 5V
(44) U624-1	CC CLAMP AMP output (Sheet 4)	CV mode =+2.2V      CC mode = +2.2V
(45) U622-6	1ST I AMP output (Sheet 4)	CV mode =0V      CC mode = -0.4V
(46) U620-7	2ND I AMP output (Sheet 4)	CV mode =0V      CC mode = +4.5V
(47) U620-1	CC CONTROL (Sheet 4)	CV mode =+10V      CC mode = +0.4V

**Table 6-3. Test Points (continued)**

TEST POINT No. & Loc.	Signal Tested	Measurement and Conditions	
<b>A10 Control Board (continued)</b>			
<b>48</b> U502-3	CC* (Sheet 4)	CV mode = +5V	CC mode = 0V
<b>49</b> Y608-7	FAST SENSE AMP (Sheet 3)	CV mode = -4V	CC mode = 0V
<b>50</b> U607-7	RAMP GEN (Sheet 3)	See Figure 6-1	
<b>51</b> U607-1	RAMP GEN (Sheet 3)	See Figure 6-1	
<b>52</b> U602-9	DIVIDER output (Sheet 3)	See Figure 6-1	
<b>53</b> U605-3	SUMMING POINT (Sheet 3)	See Figure 6-1	
<b>54</b> U602-6	DEADTIME LATCH (Sheet 3)	See Figure 6-1	
<b>55</b> U605-7	SUMMING COMPARATOR (Sheet 3)	See Figure 6-1	
<b>56</b> U600-10	DIVIDER CLOCK (Sheet 3)	See Figure 6-1	
<b>57</b> U601-6	DIVIDER RESET (Sheet 3)	See Figure 6-1	
<b>58</b> U601-3	ON LATCH CLOCK (Sheet 3)	See Figure 6-1	
<b>59</b> U604-3	ON LATCH (Sheet 3)	See Figure 6-1	
<b>60</b> U603-3	PWM_EN (Sheet 3)	Held high for approximately 12 seconds at power-on, then goes low.	
<b>61</b> U603-13	VOS (Sheet 3)	+5 ± 0.2V	
<b>NOTE:</b> Temporarily move both scope leads to J511 for TP <b>62</b>			
<b>62</b> J511-1,2	DRV A, DRV B (Sheet 3)	See Figure 6-1	
<b>63</b> U502-14		+5V	
<b>64</b> U501-7	OVREF (Sheets 1,3)	+5.4V	
<b>65</b> Q602,C	DP CONTROL (Sheet 3)	CV Mode	CC Mode
		Not Applicable	-0.14V
<b>66</b> U608-7	DP CONTROL (Sheet 3)	CV Mode	CC Mode
		+13V	0V
<b>67</b> U630-11	PREF_2 (Sheets 1,3)	+1V	
<b>68</b> U630-12	DN PGM (Sheets 1,3)	0V	
<b>69</b> D660-AN	DP_TST (Sheet 3)	0V	
<b>70</b> U502-12	OV COMPARATOR (Sheet 3)	CV Mode	CC Mode
		+1.5V	+3.25V

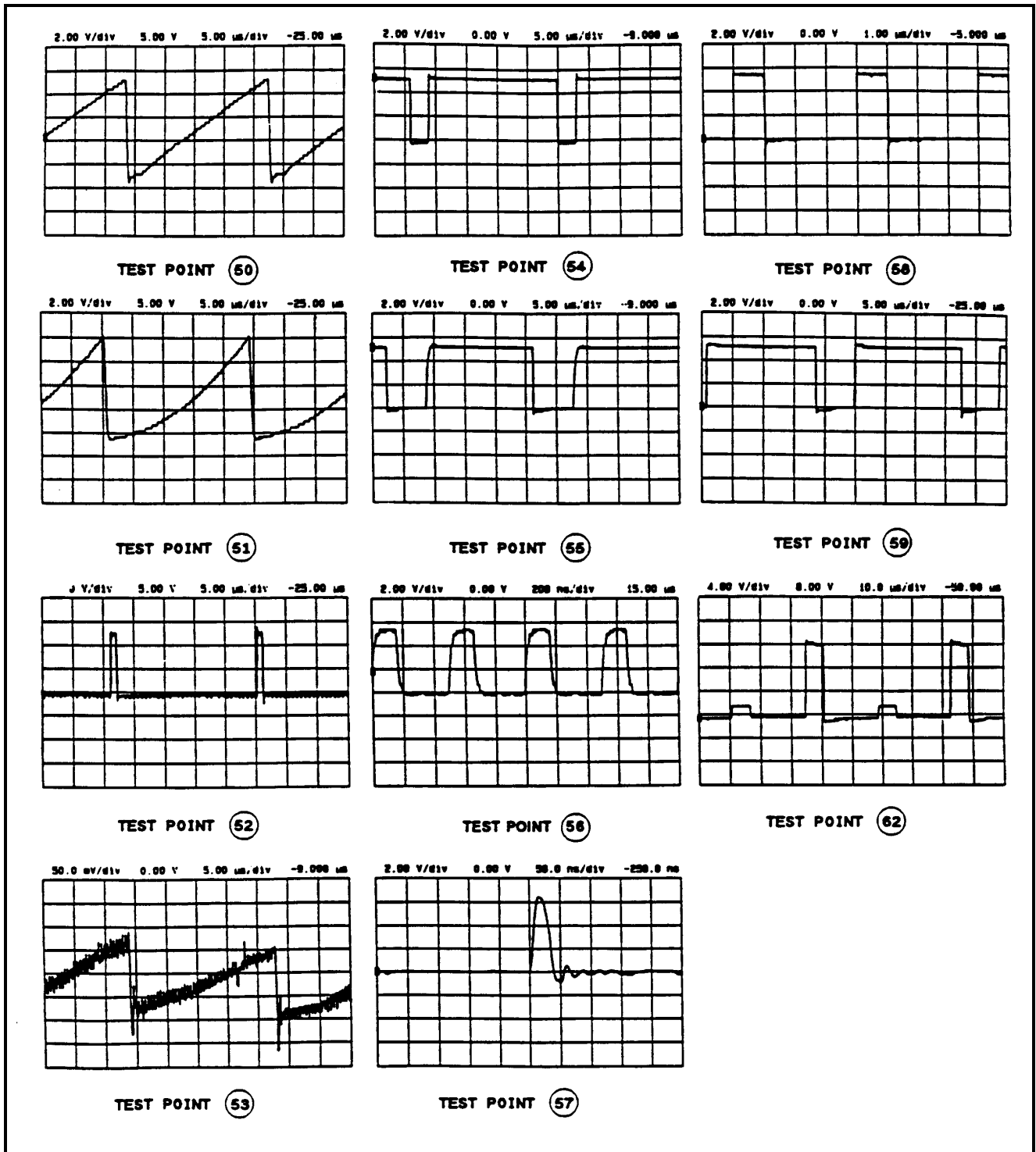

Figure 6-1. Test Point Waveforms for Table 6-3



---

## General Schematic Notes

The following table lists summary information about notes appearing in schematic diagrams.

**Table 6-4. General Schematic Notes**

1. All resistors are in ohms  $\pm 1\%$ , 1/8W, unless otherwise specified.
2. All capacitors are in microfarads unless otherwise specified.
3. Signal lines that are terminated by flags continue on other sheets, and may also go to other locations on the same sheet. Example: CVPROG (SH.2 8C); "SH.2 8C" indicates the sheet number and the coordinates on that sheet where the CVPROG signal line goes.
4. Unterminated signal lines go to a least one other location on the same sheet.
5. Unless otherwise noted, bias connections to integrated-circuit packages are as follows:

	<b>Common</b>	<b>+ 5V</b>
14-pin packages	pin 7	pin 14
16-pin packages	pin 8	pin 16
20-pin packages	pin 10	pin 20

**Figure 6-2. Circuit Board Cabling Diagram**

**Figure 6-3. A1 Front Panel Board, Component Location Diagram**

**Figure 6-4. A1 Front Panel Board, Schematic Diagram**

**Figure 6-5. LED Board, Component Test Point Location**

**Figure 6-6. LED Board, Schematic Diagram**

**Figure 6-7. A2 HP-IB Component Board, Test Point Location**

**Figure 6-8. A2 HP-IB Board, Schematic Diagram**



**Figure 6-9. A3 FET Board, Component Test Point Location**

**Figure 6-10. A3 FET Board, Schematic Diagram**

**Figure 6-11. A4 AC Input Board, Component Test Point Location**

**Figure 6-12. A4 AC Input Board, Schematic Diagram**

**Figure 6-13. A5 DC Rail Board, Component Test Point Location**

**Figure 6-14. A5 DC Rail Board, Schematic Diagram**

**Figure 6-15. A6 Bias Board, Component Test Point Location**

**Figure 6-16. A6 Bias Board, Schematic Diagram (Sheet 1)**



**Figure 6-17. Power Mesh, Schematic Diagram Models 6680A, 6681A Only**

**Figure 6-18. Power Mesh, Schematic Diagram Models 6682A, 6683A, 6684A**

**Figure 6-19. A7 Snubber Board, Component Location**

**Figure 6-20. A7 Snubber Board, Schematic Diagram**

**Figure 6-21. A8 Fast Sense Board, Component Location**

**Figure 6-22. A8 Fast Sense Board, Schematic Diagram**

**Figure 6-23. A9 Down Programmer/Slow Sense, Component Location**

**Figure 6-24. A9 Down Programmer/Slow Sense, Schematic Diagram**



**Figure 6-25. A10 Control Board, Component Test Point Location**

**Figure 6-26. A10 Control Board, Schematic Diagram**

## Backdating

Manual backdating describes changes that must be made to this manual for power supplies whose serial numbers are lower than those listed in the title page to this manual.

Look in the following table and locate your HP Model. Then look at each serial number listed for this group. If the serial number of your power supply is **prior** to any of the serial number(s) listed, perform the change indicated in the **Change** column. Note that, several changes can apply to your supply.

Serial Numbers	Change
<b>Model 6680A</b>	
3318A 00111	1, 2, 4, 5, 6
3318A 00116	3
3502A 00126	7
3619A 00167	9
<b>Model 6681A</b>	
3319A 00154	4
3336A 00164	1
3350A 00172	2, 6
3350A 00183	5
3350A 00193	3
3506A 00218	7
3619A 00383	9
<b>Model 6682A</b>	
3349A 00104	6
3349A 00108	3
3514A 00123	7
3514A 00168	8
3624A 00193	9

Serial Numbers	Change
<b>Model 6683A</b>	
3349A 00104	6
3349A 00108	3
3514A 00123	7
3514A 00178	8
3619A 00203	9
<b>Model 6684A</b>	
3339A 00103	5
3405A 00108	3
3405A 00109	6
3514A 00118	7
3514A 00188	8
3514A 00257	9

### CHANGE 1

**In Table 5-14 A10 Control Board**

**DELETE** C548, 0.1uF 50V, HP P/N 0160-4835 in parallel with RT500.

### CHANGE 2

**In Table 5-7 A3 FET Board**

**DELETE** C228 & 231, 2000pF 100V P/N 0160-2301.

**ADD** C228, 6800pF 100V P/N 0160-4904.

**CHANGE** R247, from 75K P/N 0757-0462, to 42.2K 1% 1/8W P/N 0698-3450.  
 R249, from 13.1K P/N 0757-0444, to 7.5K 1% 1/8W P/N 0757-0440  
 R250, from 60.4K P/N 0698-3572 to 40.2K 1% 1/8W P/N 0698-3499.  
 R253, from 12.5K P/N 0698-6533 to 17.8K 1% 1/8W P/N 0698-3136.  
 C229, from 0.022uF P/N 0160-4918 to 0.01uF 100V Ceramic P/N 0160-4832.

**In Table 5-9 A5 DC Rail Board**

**DELETE** C418, 0.022uF 250VAC "Y" rated P/N 0160-4048  
Fuse Clips, REF F420 & 421 1/4" P/N 2110-0726, qty, 4.

**ADD** Fuse Holder, REF F420 & 421, 5 x 30mm P/N 2110-0689, qty 2.

**CHANGE** F420 & 421, from 0.5A 500V P/N 2110-0934 to 0.5A 500V 5x30mm P/N 2110-0921.

### **CHANGE 3**

#### **In Table 5-14 A10 Control Board**

**DELETE** C548, 0.1uF 50V P/N 0160-4835. in parallel with RT500.  
RT500, P/N 0837-0412.  
Pins, P/N 0360-1498, qty. 2.

### **CHANGE 4**

#### **In Table 5-14 A10 Control Board**

**DELETE** ASSEMBLY, relay contactor P/N 5060-3593, qty. 1.

**ADD** Dust cover for relay, P/N 9222-1870.  
Retainer clip for relay, P/N 1460-2317.  
Relay, P/N 0490-1919.

### **CHANGE 5**

#### **In Table 5-8 A4 AC Input Board**

**DELETE** C428, 429, and 430, P/N 0160-7898.  
R435, 436, and 437, P/N 0698-3609.

### **CHANGE 6**

#### **In Table 5-6 A2 HP-IB Board**

**CHANGE** A2 HP-IB board from P/N 5060-3591 to P/N 5060-3552.

### **CHANGE 7**

#### **In Table 5-6 A2 HP-IB Board**

**CHANGE** U114 from P/N 1826-0536, to LM309K P/N 1820-0430.

### **CHANGE 8**

#### **In Table 5-13 A9 Downprogrammer/Slow Sense Board**

**CHANGE** Q981, 982 from P/N 1855-1003, to POWER MOSFET P/N 1855-0835.

**DELETE** Insulator, REF Q981, 982.

### **CHANGE 9**

#### **In Table 5-10 A1 Front Panel Board**

**CHANGE** KNOB (Ref. RPG) from P/N 0370-3238, to P/N 10370-1091.  
RPG - OPTICAL ENCODER from P/N 0960-0912 to P/N 0960-0822.  
U4 from 5080-2466 to P/N 5080-2304.

**DELETE** PCA (keypad), P/N 5063-3407.

# Index

## A

A1 Front Panel Board, test header .....	57
A2 HP-IB Board, test header .....	57
A3 FET Board	
dynamic troubleshooting .....	55
static troubleshooting .....	55
test connections .....	55
test points .....	55, 56
analog port .....	8

## B

bias supply .....	36
-------------------	----

## C

cable	
W3 ribbon .....	79
W4 phone .....	79
W5 phone .....	79
W6 ac bias .....	79
Cabling diagram .....	146
calibration constants, factory .....	66
calibration password .....	65
calibration, post-repair .....	65
calibration procedure .....	7
CC annunciator .....	55
CC load effect, testing .....	26
CC noise (PARD), testing .....	18
CC PARD, defined .....	18
Circuits	
isolator board .....	84
conductive table mat .....	9
conductive wrist strap .....	9
configuration jumper	
FACTORY PRESET CAL .....	59
FLT/INH .....	59
INHIBIT CAL .....	59
RELAY LINK .....	59
SA mode .....	59
current, maximum programmable .....	19
current, --CC .....	19
current programming and readback accuracy, testing .....	19
current sink and readback accuracy, testing .....	19
CV/CC status annunciators .....	54
CV load effect, defined .....	16
CV load effect, testing .....	16
CV noise (PARD), defined .....	17
CV noise (PARD), testing .....	17

CV source effect, defined .....	17
CV source effect, testing.....	17
CV transient response waveform .....	18
CV transient recovery time, defined .....	18
CV transient recovery time, testing .....	18
CV voltage programming and readback accuracy, testing.....	16

## D

Diagram cabling.....	146
DIG CNTL port,configuring.....	58
disassembly procedures.....	71
downprogrammer FETs,location of .....	74

## E

electronic load .....	12, 20
error,checksum .....	35
error code	
E1 .....	35
E10 .....	35
E11 .....	35
E12 .....	35
E2 .....	35
E3 .....	35
E4 .....	35
E5 .....	35
E6 .....	35
E7 .....	35
E8 .....	35
E9 .....	35
error code,over HP-IB .....	35
error code,selftest .....	35
error message	
CAL DENIED .....	67
DACS .....	35
EE CHKSM.....	35
EE WRITE ERR.....	35
FP RAM .....	35
FP ROM .....	35
FRAMING.....	35
HP-IB .....	35
PASSWD ERROR.....	67
PRI IRAM .....	35
PRI ROM.....	35
PRI XRAM.....	35
SBuF FULL.....	35
SBuF OVERRUN.....	35
SEC 5V.....	35
SECONDARY DWN .....	35
SEC RAM.....	35
SEC ROM.....	35
SERIAL DOWN.....	35
SERIAL TIMEOUT .....	35
TEMP .....	35

UART OVERRUN.....	35
UART PARITY.....	35
error message,selftest.....	35
errors	
calibration.....	35
selftest.....	35
ESD.....	9, 33

## F

factory calibraion constants.....	65
firmware,revisions.....	8
firmware revisions.....	64
Form, performance test record.....	25
front panel EEPROM	
factory cal location.....	67
initialization of.....	67
transferring constants to.....	67
front panel operation.....	7
front panel,testing.....	34

## H

HP 50504A oscilloscope.....	34
HP 545A logic probe.....	34
HP-IB error 2.....	66
HP-IB interface,testing.....	34

## I

*IDN query.....	58
inhibit calibration jumper.....	66
Isolator board circuits.....	87

## J

jumper	
DIG I/O.....	59
FACTORY PRESET CAL.....	59
INHIBIT CAL.....	59
NORM.....	59

## K

keypad.....	14
-------------	----

## L

line fuse, replacing.....	9
line voltage, conversion of.....	9

## M

manual backdating.....	8
------------------------	---

manual changes sheet.....	8
manuFacturing date,determining.....	8
message	
PWR ON INIT .....	35, 65
Mnemonics signal names .....	140
mutual coupling, test lead .....	14

## N

noise, testing .....	14
----------------------	----

## O

operating manual .....	7
oscilloscope, HP 54504A .....	15
output heatsink assembly .....	82
output rectifiers	
location of.....	75
replacing .....	75
overvoltage, maximum programmable .....	14

## P

Performance test record form .....	25
performance tests, CC.....	19
performance tests, CV .....	16
power FETs,replacing.....	47
power-on selftest.....	34
power-on selftest,disabling .....	34
protective earth ground .....	9

## R

record sheet, test .....	13
reference supply.....	34
regulation, voltage .....	14
removng	
A1 Front Panel Assembly .....	74
A1 Front Panel Board .....	74
A2 HP-IB Board.....	72
A3 FET Board .....	73
A4 AC Input Board .....	72
A5 Control Board .....	73
A6 Output Filter Board.....	73
A7 Snubber Board .....	75
ac input filter .....	72
fan.....	73
heatsink assembly .....	73
keypad .....	75
L900 output choke.....	75
line switch.....	72
output subchassis .....	75
rear panel .....	72
RFI shield .....	72
RPG controls .....	73



T900 output transformer .....	72
top cover .....	73
Replaceable parts for A2 isolator board .....	104
resistor	
current monitoring .....	12
load .....	12
resistor, current monitor .....	12
resistor, current monitoring .....	12

## S

SA .....	58
SA secondary interface, exiting test .....	58
SA signals	
A5 microprocessor .....	59
SA signals, secondary interface .....	59
SA signatures, identical .....	60
SA signatures, similar .....	60
SA test header jumper .....	60
Schematic notes .....	145
SCPI programming .....	8
secondary interface, testing .....	33
sense terminals .....	13
serial number .....	7
serial number prefix .....	7
settling time .....	13
Signal name	
mnemonics .....	140
Signals	
+5V bias voltage .....	140
BSTx .....	140
PCLR .....	140
RESET* .....	140
RxD .....	140
SPCLR* .....	140
SRx .....	140
TxD .....	140
XFMR T1 .....	140
slew rate .....	13

## T

test	
selftest .....	11
test equipment, troubleshooting .....	33
test headers .....	35
test leads .....	13
test measurements, cc mode .....	19
test points, troubleshooting .....	35
Test point waveforms .....	144
tests	
constant-current mode .....	19
constant-voltage mode .....	14
independent order of .....	14
operation verification .....	14

performance.....	14
programming.....	13
performance test record.....	25
TORX screws.....	71
transformer, variable-voltage.....	18
transient recovery time.....	18
Troubleshooting	
test points.....	142
troubleshooting chart	
output held high.....	36
OV at turn-on.....	36
secondary downprogramming.....	36
troubleshooting charts.....	36
*TST?.....	34
*TST? Query.....	34

## U

UNREGULATED annunciator.....	55
using *IDN query.....	8

## V

voltage, maximum programmable.....	13
------------------------------------	----